



Glass Type 1

Metal Panel

Metal Canopy

Glass Type 2

Glass Guardrail

Wood Door

Painted Metal

Precast Concrete

Brick

NOTES:

1. THE EXTERIOR ELEVATIONS, INCLUDING DOOR AND WINDOW SIZES AND LOCATIONS, THE INTERIOR PARTITION LOCATIONS, THE NUMBER, SIZE AND LOCATIONS OF RESIDENTIAL UNITS, STAIRS AND ELEVATIONS ARE PRELIMINARY AND SHOWN FOR ILLUSTRATIVE PURPOSES ONLY. THE PARKING SPACE LAYOUT IS SHOWN FOR ILLUSTRATIVE PURPOSES ONLY. THE FINAL LAYOUTS MAY VARY.
2. REFER TO SHEET L1 FOR LANDSCAPE PLAN.
3. REFER TO SHEET A11 (ROOF PLAN) FOR BUILDING DIMENSIONS.
4. REFER TO SHEET A18 FOR TYPICAL MATERIAL NOTATION.

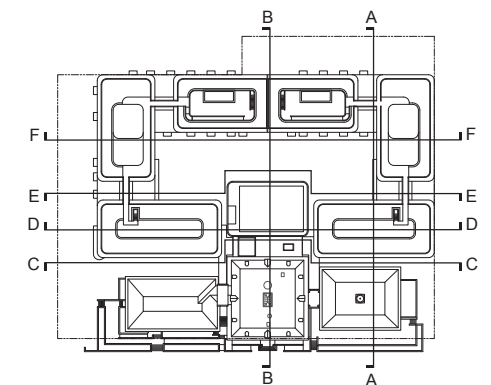
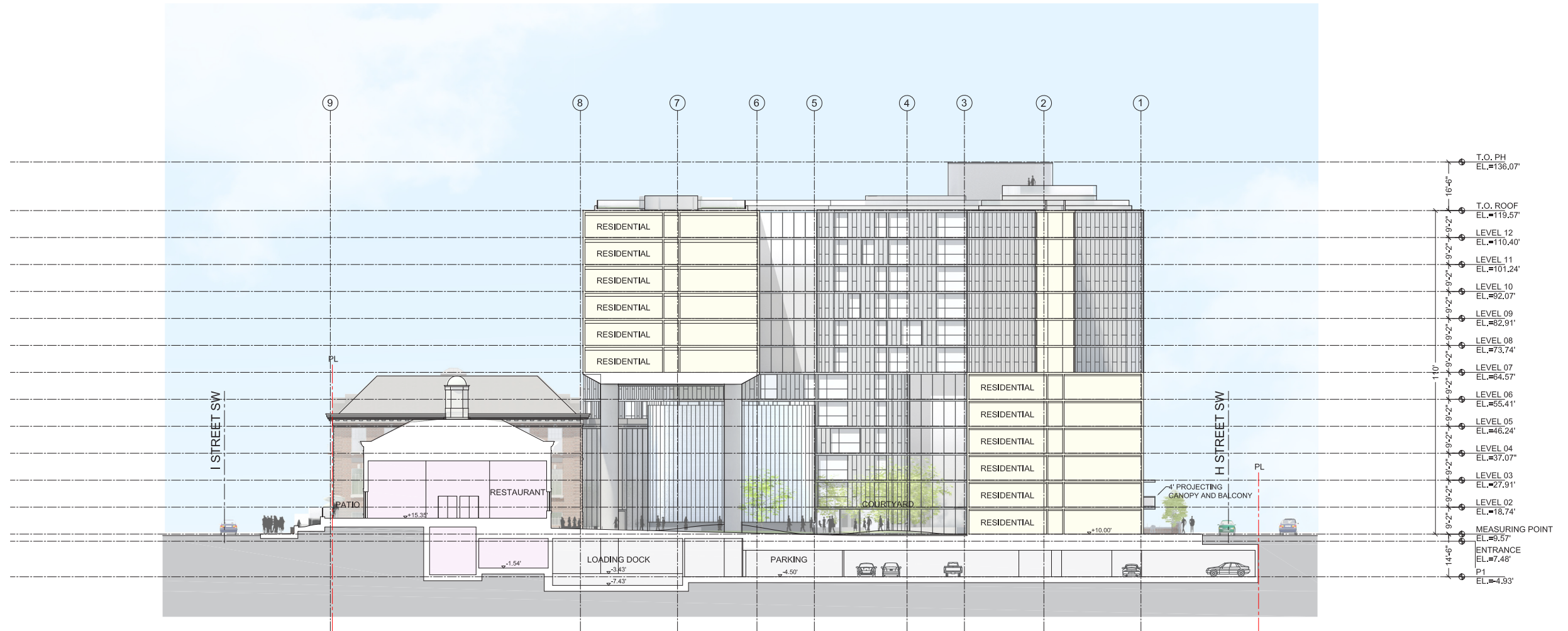

- NOTES:**
1. THE EXTERIOR ELEVATIONS, INCLUDING DOOR AND WINDOW SIZES AND LOCATIONS, THE INTERIOR PARTITION LOCATIONS, THE NUMBER, SIZE AND LOCATIONS OF RESIDENTIAL UNITS, STAIRS AND ELEVATIONS ARE PRELIMINARY AND SHOWN FOR ILLUSTRATIVE PURPOSES ONLY. THE PARKING SPACE LAYOUT IS SHOWN FOR ILLUSTRATIVE PURPOSES ONLY. THE FINAL LAYOUTS MAY VARY.
 2. REFER TO SHEET L1 FOR LANDSCAPE PLAN.
 3. REFER TO SHEET A11 (ROOF PLAN) FOR BUILDING DIMENSIONS.
 4. REFER TO SHEET A18 FOR TYPICAL MATERIAL NOTATION.

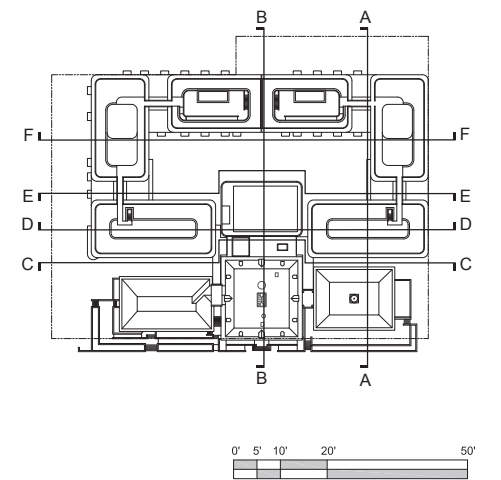
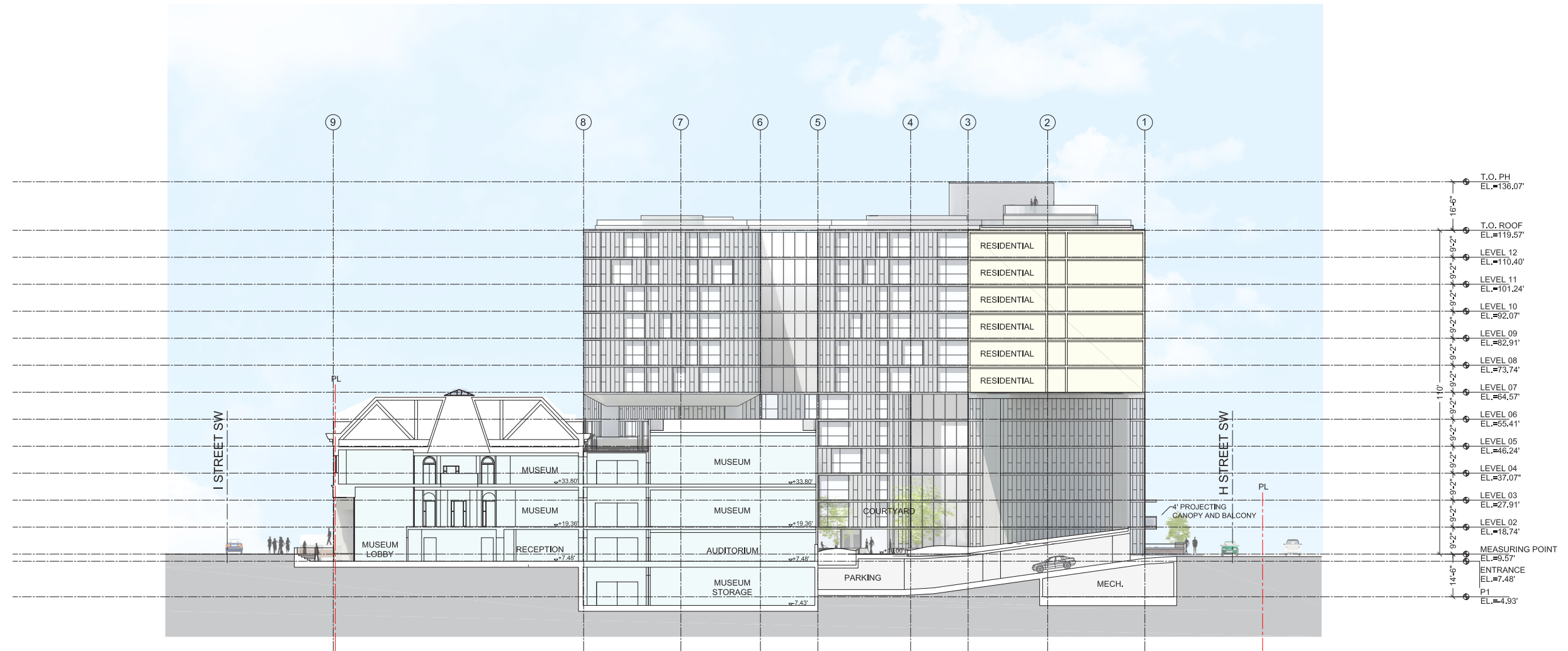

- NOTES:**
1. THE EXTERIOR ELEVATIONS, INCLUDING DOOR AND WINDOW SIZES AND LOCATIONS, THE INTERIOR PARTITION LOCATIONS, THE NUMBER, SIZE AND LOCATIONS OF RESIDENTIAL UNITS, STAIRS AND ELEVATIONS ARE PRELIMINARY AND SHOWN FOR ILLUSTRATIVE PURPOSES ONLY. THE PARKING SPACE LAYOUT IS SHOWN FOR ILLUSTRATIVE PURPOSES ONLY. THE FINAL LAYOUTS MAY VARY.
 2. REFER TO SHEET L1 FOR LANDSCAPE PLAN.
 3. REFER TO SHEET A11 (ROOF PLAN) FOR BUILDING DIMENSIONS.
 4. REFER TO SHEET A18 FOR TYPICAL MATERIAL NOTATION.

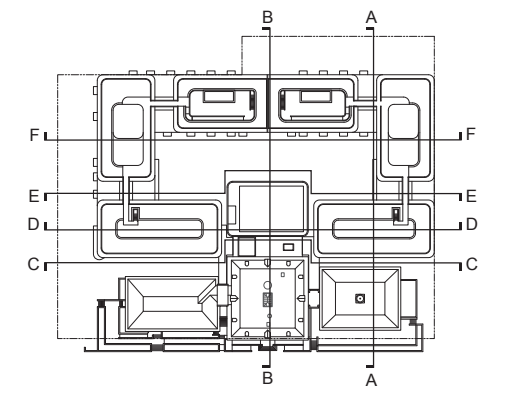
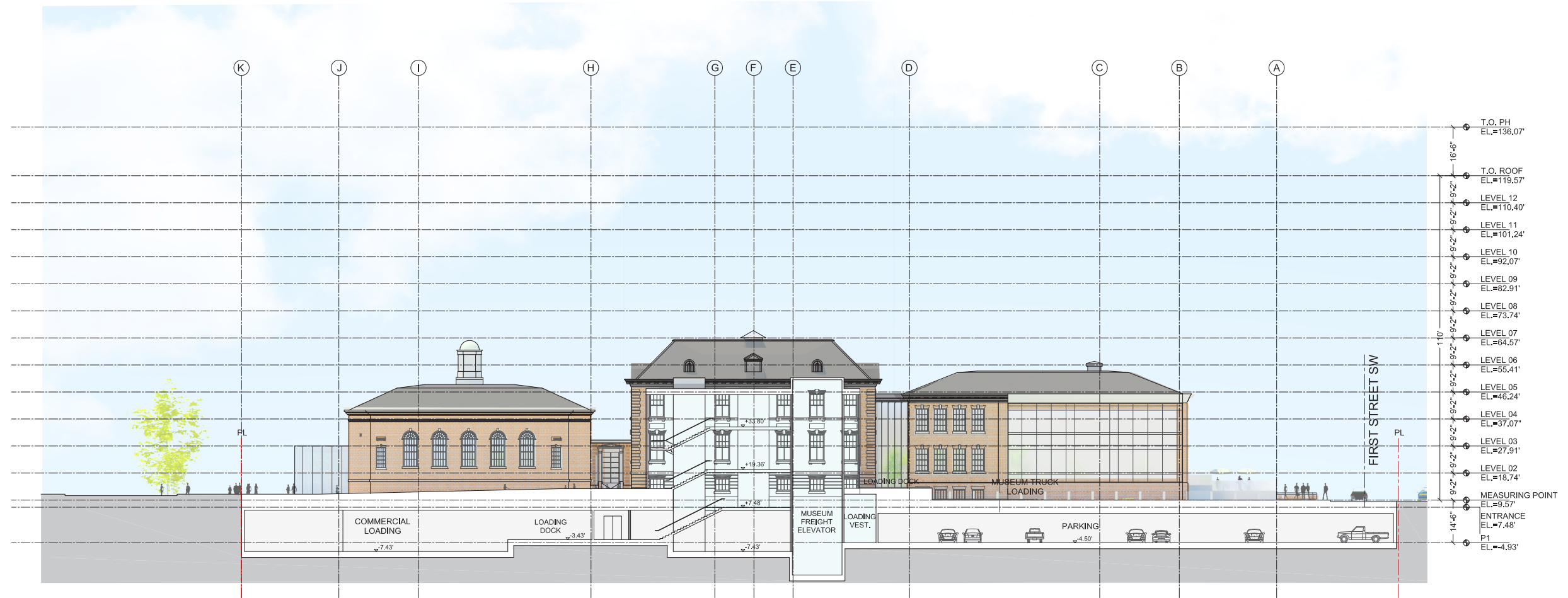

- NOTES:**
1. THE EXTERIOR ELEVATIONS, INCLUDING DOOR AND WINDOW SIZES AND LOCATIONS, THE INTERIOR PARTITION LOCATIONS, THE NUMBER, SIZE AND LOCATIONS OF RESIDENTIAL UNITS, STAIRS AND ELEVATIONS ARE PRELIMINARY AND SHOWN FOR ILLUSTRATIVE PURPOSES ONLY. THE PARKING SPACE LAYOUT IS SHOWN FOR ILLUSTRATIVE PURPOSES ONLY. THE FINAL LAYOUTS MAY VARY.
 2. REFER TO SHEET L1 FOR LANDSCAPE PLAN.
 3. REFER TO SHEET A11 (ROOF PLAN) FOR BUILDING DIMENSIONS.
 4. REFER TO SHEET A18 FOR TYPICAL MATERIAL NOTATION.

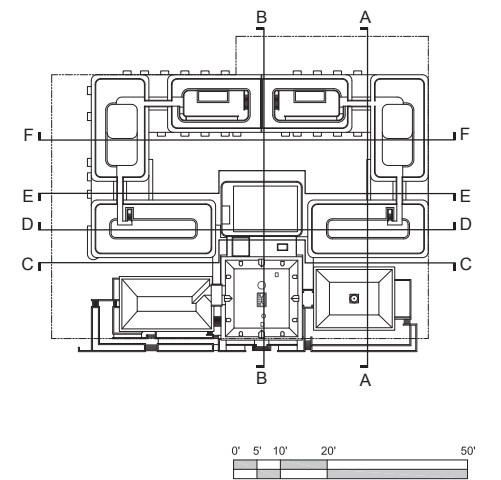
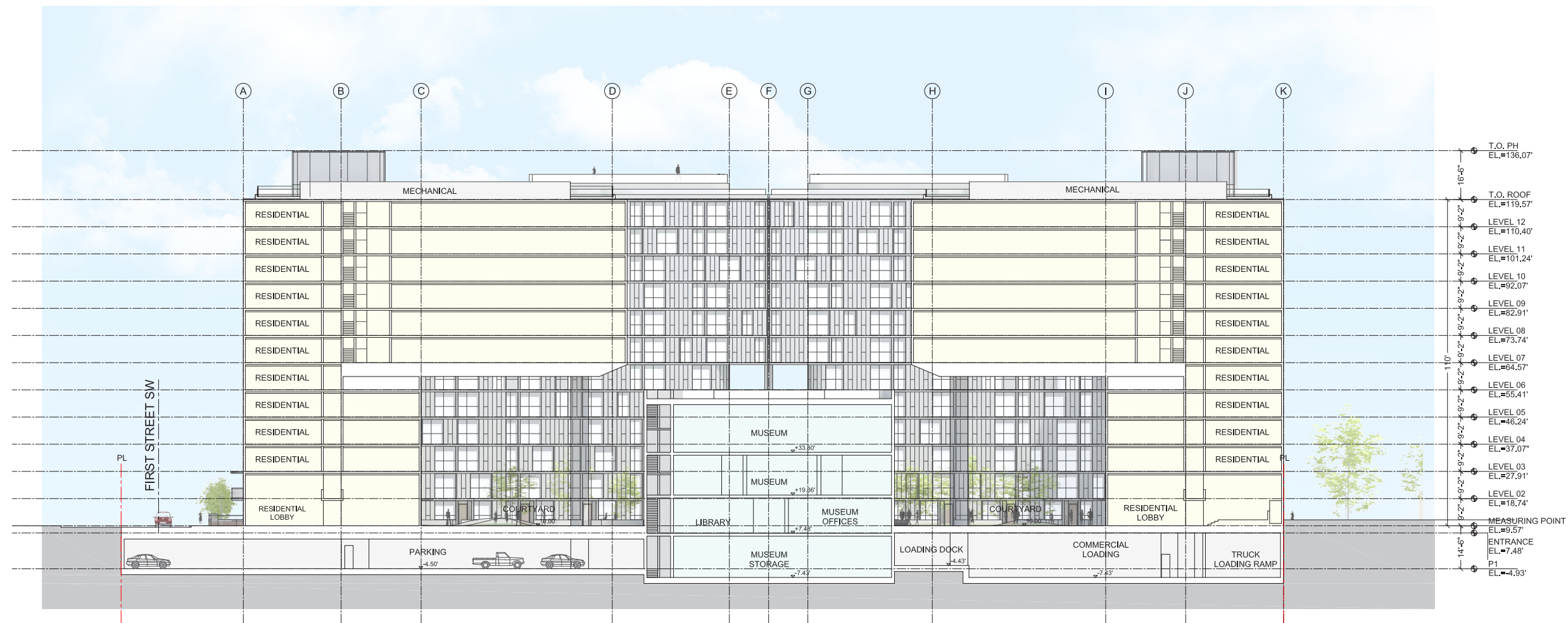

- NOTES:**
1. THE EXTERIOR ELEVATIONS, INCLUDING DOOR AND WINDOW SIZES AND LOCATIONS, THE INTERIOR PARTITION LOCATIONS, THE NUMBER, SIZE AND LOCATIONS OF RESIDENTIAL UNITS, STAIRS AND ELEVATIONS ARE PRELIMINARY AND SHOWN FOR ILLUSTRATIVE PURPOSES ONLY. THE PARKING SPACE LAYOUT IS SHOWN FOR ILLUSTRATIVE PURPOSES ONLY. THE FINAL LAYOUTS MAY VARY.
 2. REFER TO SHEET L1 FOR LANDSCAPE PLAN.
 3. REFER TO SHEET A11 (ROOF PLAN) FOR BUILDING DIMENSIONS.
 4. REFER TO SHEET A18 FOR TYPICAL MATERIAL NOTATION.

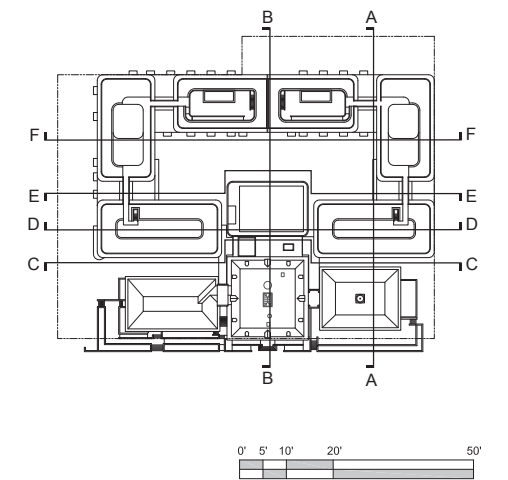
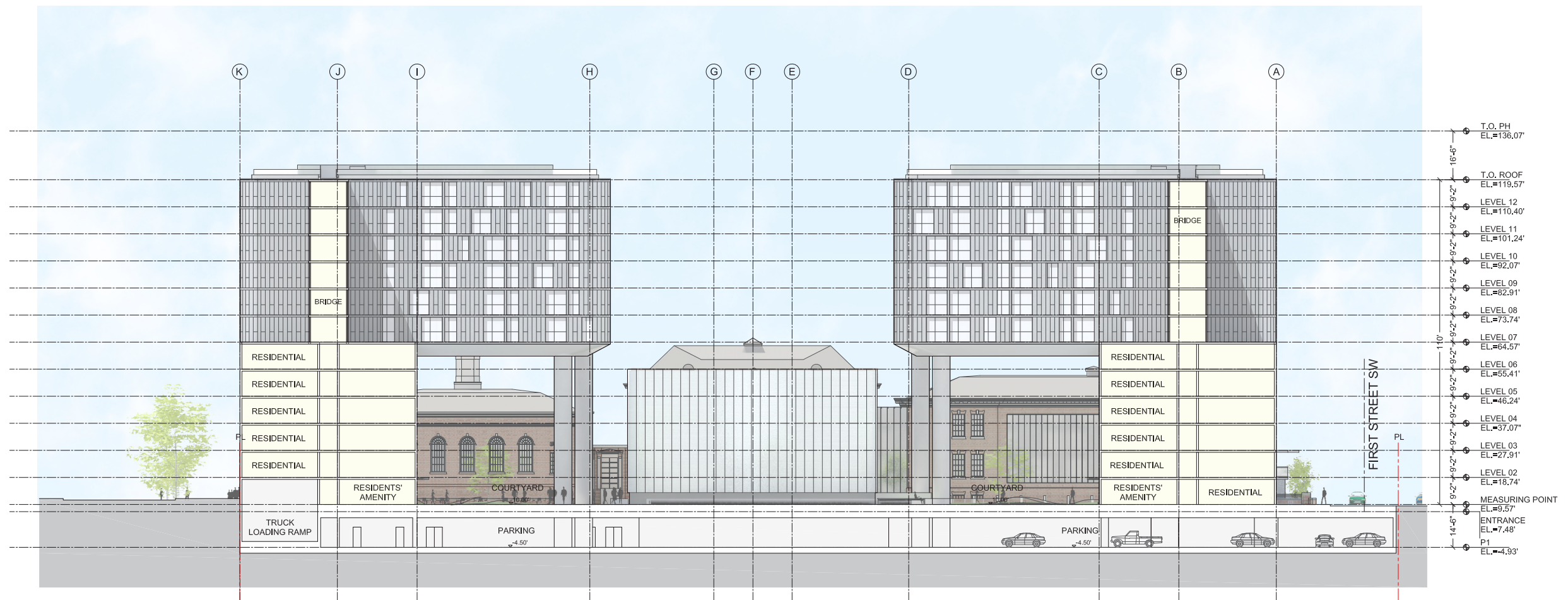

- NOTES:**
1. THE EXTERIOR ELEVATIONS, INCLUDING DOOR AND WINDOW SIZES AND LOCATIONS, THE INTERIOR PARTITION LOCATIONS, THE NUMBER, SIZE AND LOCATIONS OF RESIDENTIAL UNITS, STAIRS AND ELEVATIONS ARE PRELIMINARY AND SHOWN FOR ILLUSTRATIVE PURPOSES ONLY. THE PARKING SPACE LAYOUT IS SHOWN FOR ILLUSTRATIVE PURPOSES ONLY. THE FINAL LAYOUTS MAY VARY.
 2. REFER TO SHEET L1 FOR LANDSCAPE PLAN.
 3. REFER TO SHEET A11 (ROOF PLAN) FOR BUILDING DIMENSIONS.
 4. REFER TO SHEET A18 FOR TYPICAL MATERIAL NOTATION.

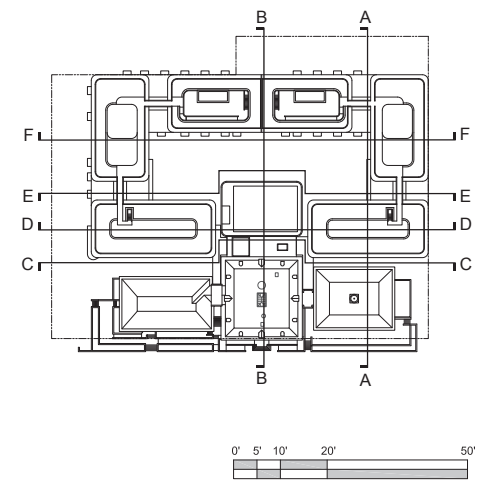

- NOTES:**
1. THE EXTERIOR ELEVATIONS, INCLUDING DOOR AND WINDOW SIZES AND LOCATIONS, THE INTERIOR PARTITION LOCATIONS, THE NUMBER, SIZE AND LOCATIONS OF RESIDENTIAL UNITS, STAIRS AND ELEVATIONS ARE PRELIMINARY AND SHOWN FOR ILLUSTRATIVE PURPOSES ONLY. THE PARKING SPACE LAYOUT IS SHOWN FOR ILLUSTRATIVE PURPOSES ONLY. THE FINAL LAYOUTS MAY VARY.
 2. REFER TO SHEET L1 FOR LANDSCAPE PLAN.
 3. REFER TO SHEET A11 (ROOF PLAN) FOR BUILDING DIMENSIONS.
 4. REFER TO SHEET A18 FOR TYPICAL MATERIAL NOTATION.