



GOROVE SLADE
Transportation Planners and Engineers

WILLES
WIMENSCH
CONSULTANTS ARCHITECTS ENGINEERS

DLRGROUP

REDBRICK
LMD

TRAFFIC



GOROVE SLADE
Transportation Planners and Engineers

WILES
MEN SCH

DLR GROUP

REDBRICK
LMD

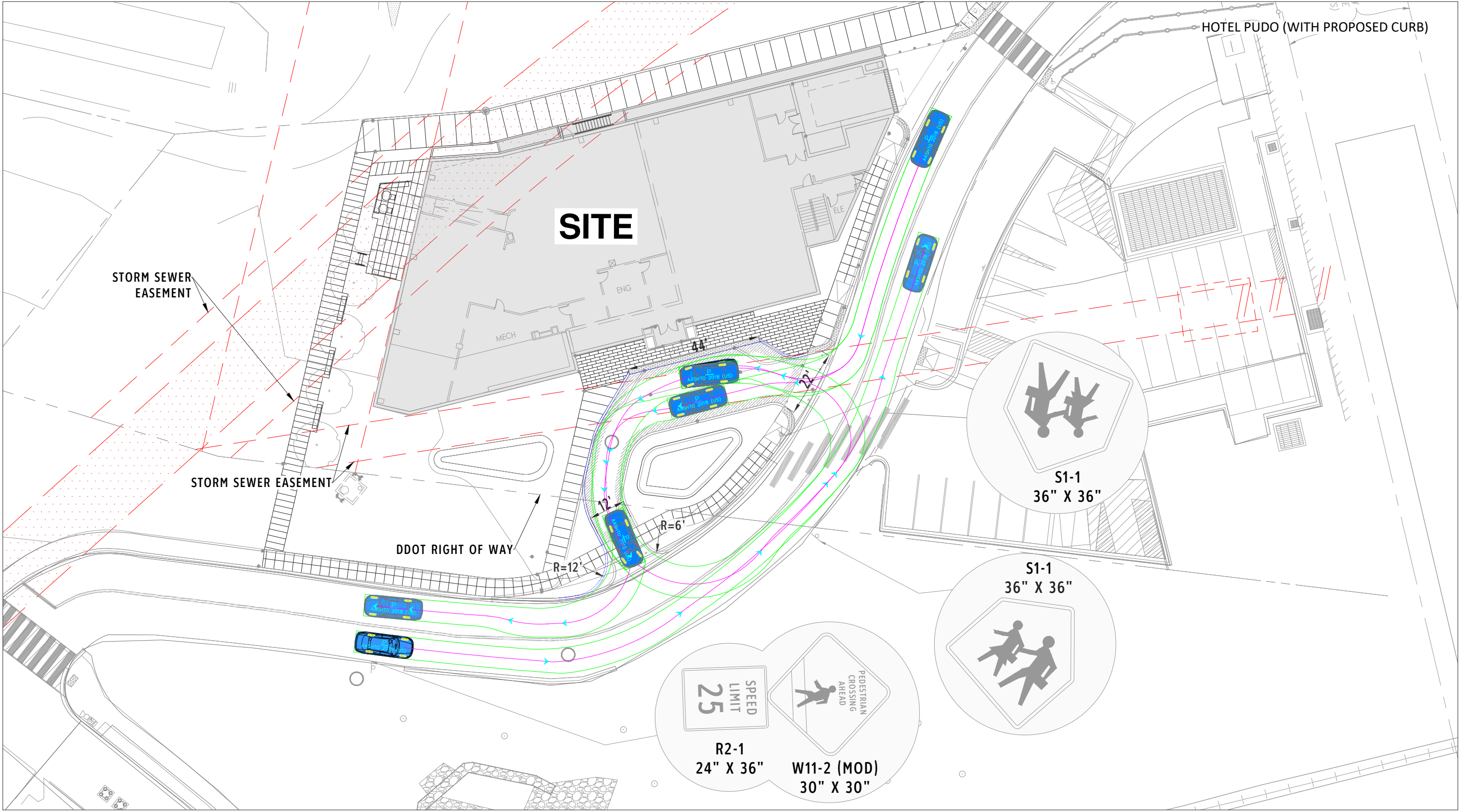

SCALE: 1" = 30'



GOROVE SLADE
Transportation Planners and Engineers

WILES
MENSCHE

DLR GROUP

REDBRICK
LMD

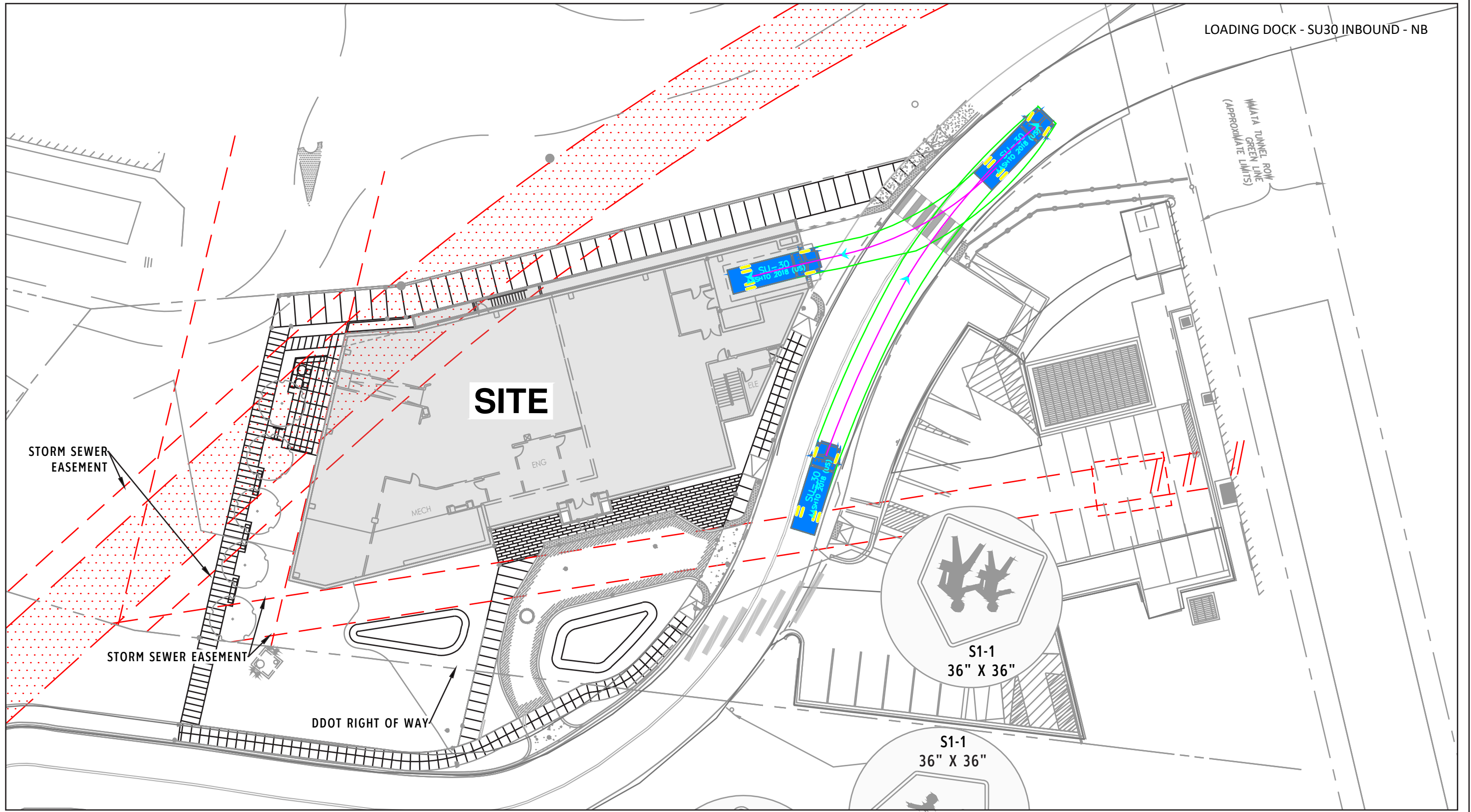

SCALE: 1" = 30'



GOROVE SLADE
Transportation Planners and Engineers

WILES
MENSCHE

DLR GROUP

REDBRICK
LMD

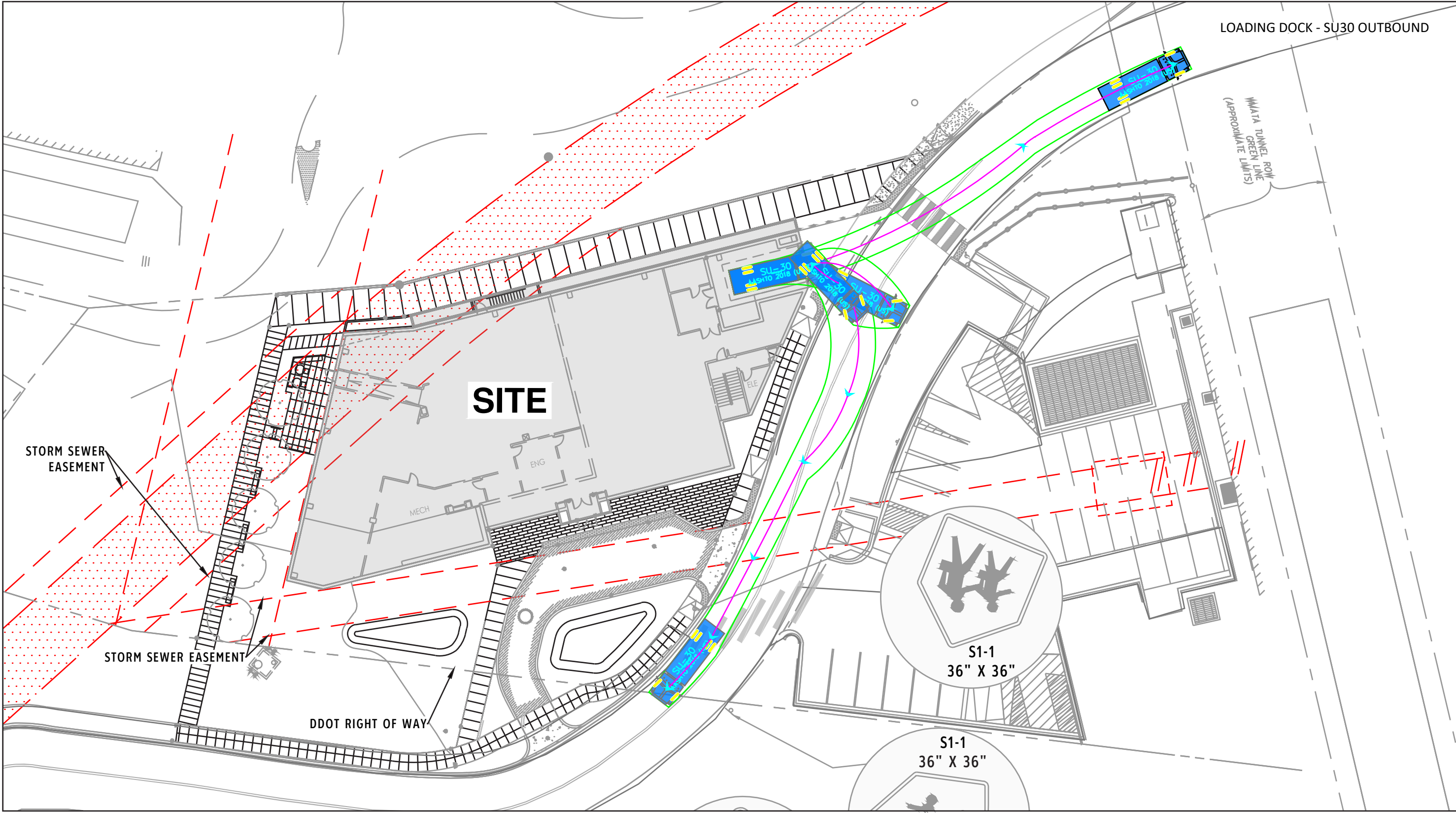

SCALE: 1" = 30'

AutoTurn Notes:

- AutoTurn is a kinematic model and does not account for inertia
- AutoTurn does not account for weather and/or pavement conditions
- AutoTurn cannot compensate for driver error or experience
- Other drivable paths may achieve the same result(s) shown
- AutoTurn is a conservative model but is not a guarantee of exact real time results
- Successful simulation in AutoTurn does not guarantee that a specific driver can achieve the same pathway
- Vehicle dimensions are for standard sized vehicles, actual vehicle dimensions may vary
- Future changes to the design may impact and/or invalidate the results depicted in this exhibit
- Unless noted, AutoTurn does not account for vertical clearance or grade change.

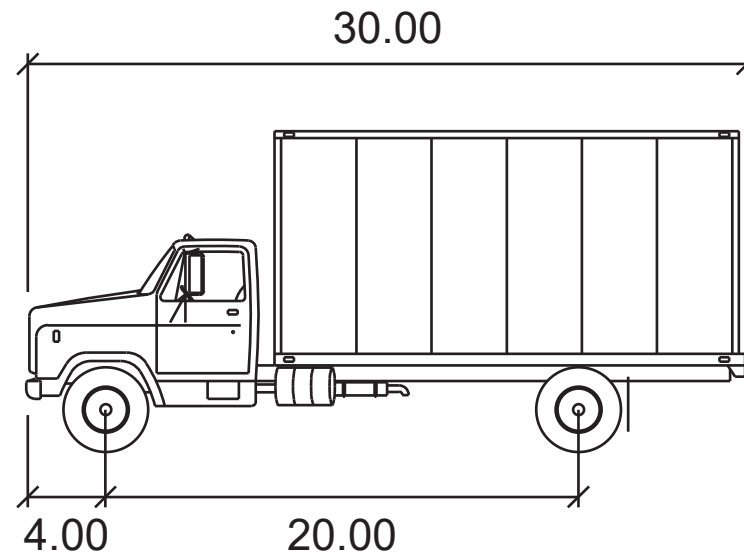
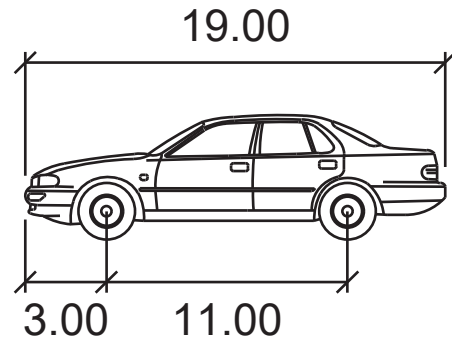

P

SU-30

	feet
Width	: 7.00
Track	: 6.00
Lock to Lock Time	: 6.0
Steering Angle	: 31.6

	feet
Width	: 8.00
Track	: 8.00
Lock to Lock Time	: 6.0
Steering Angle	: 31.8



SCALE: 1" = 30'



GOROVE SLADE
Transportation Planners and Engineers

WILES MENSCH
CONSULTANTS AND ENGINEERS

DLR GROUP

REDBRICK
LMD