



Southeast Federal Center

Parcel I

Design Review Application
For Zoning Commission Review Under the SEFC-1B Zone

April 11th, 2019

Prepared for:
The Zoning Commission of the District
of Columbia

Prepared by:
the U.S. General Services Administration
Brookfield Properties

with the Assistance of:
Perkins Eastman DC

Brookfield
Properties

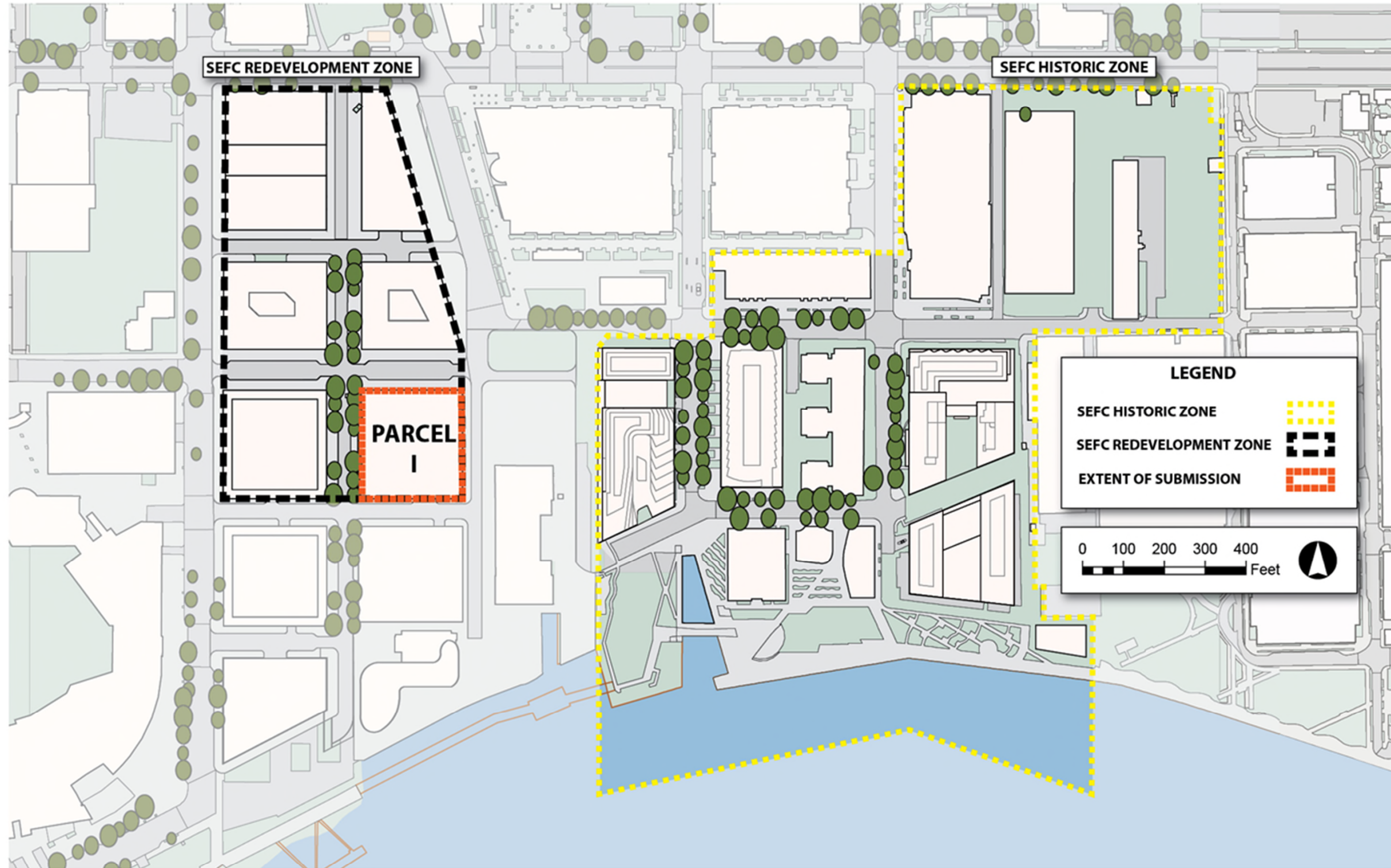

Extent of Submission
 Parcel I at The Yards West - Design Review Application
 April 11th, 2019

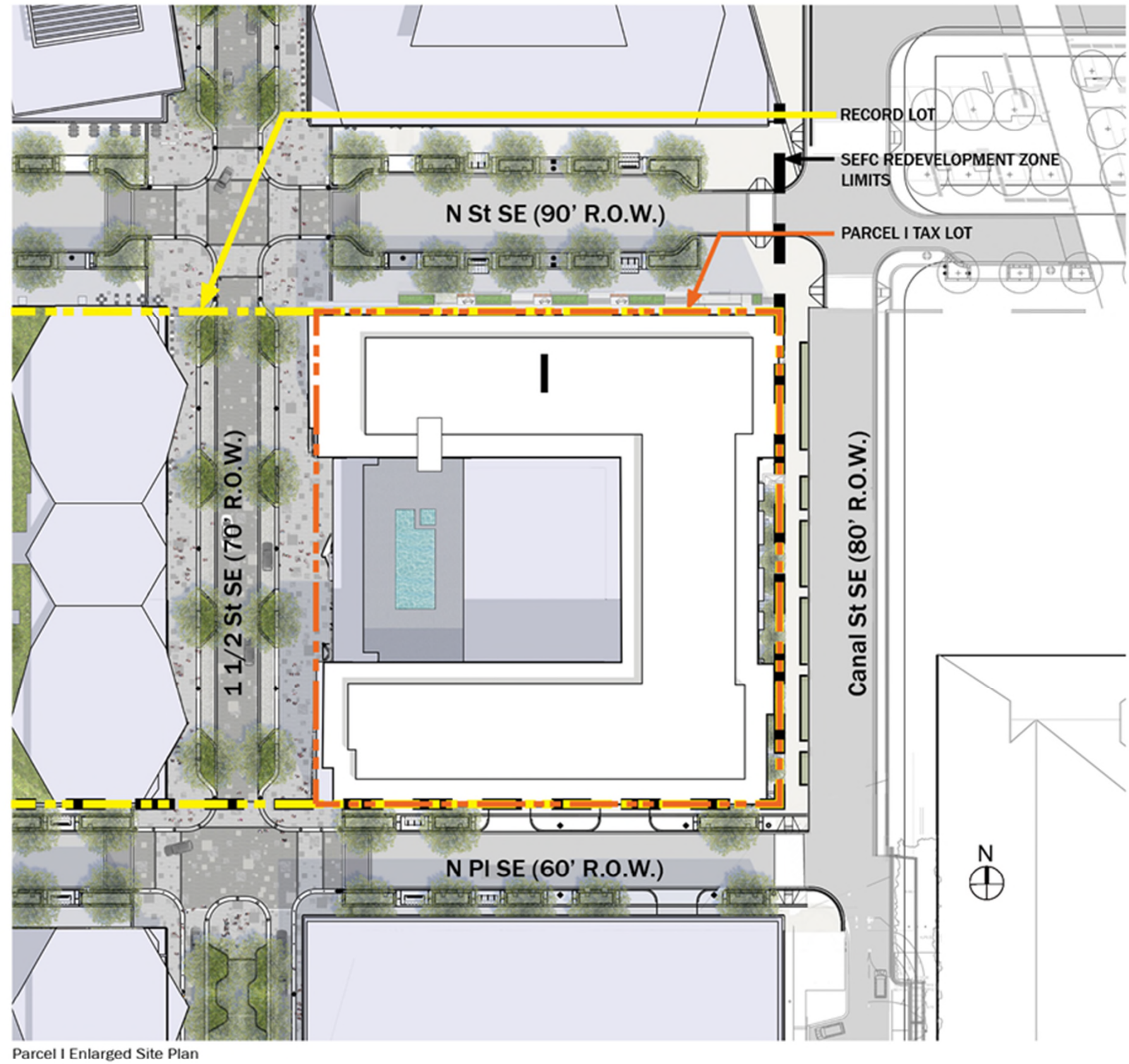
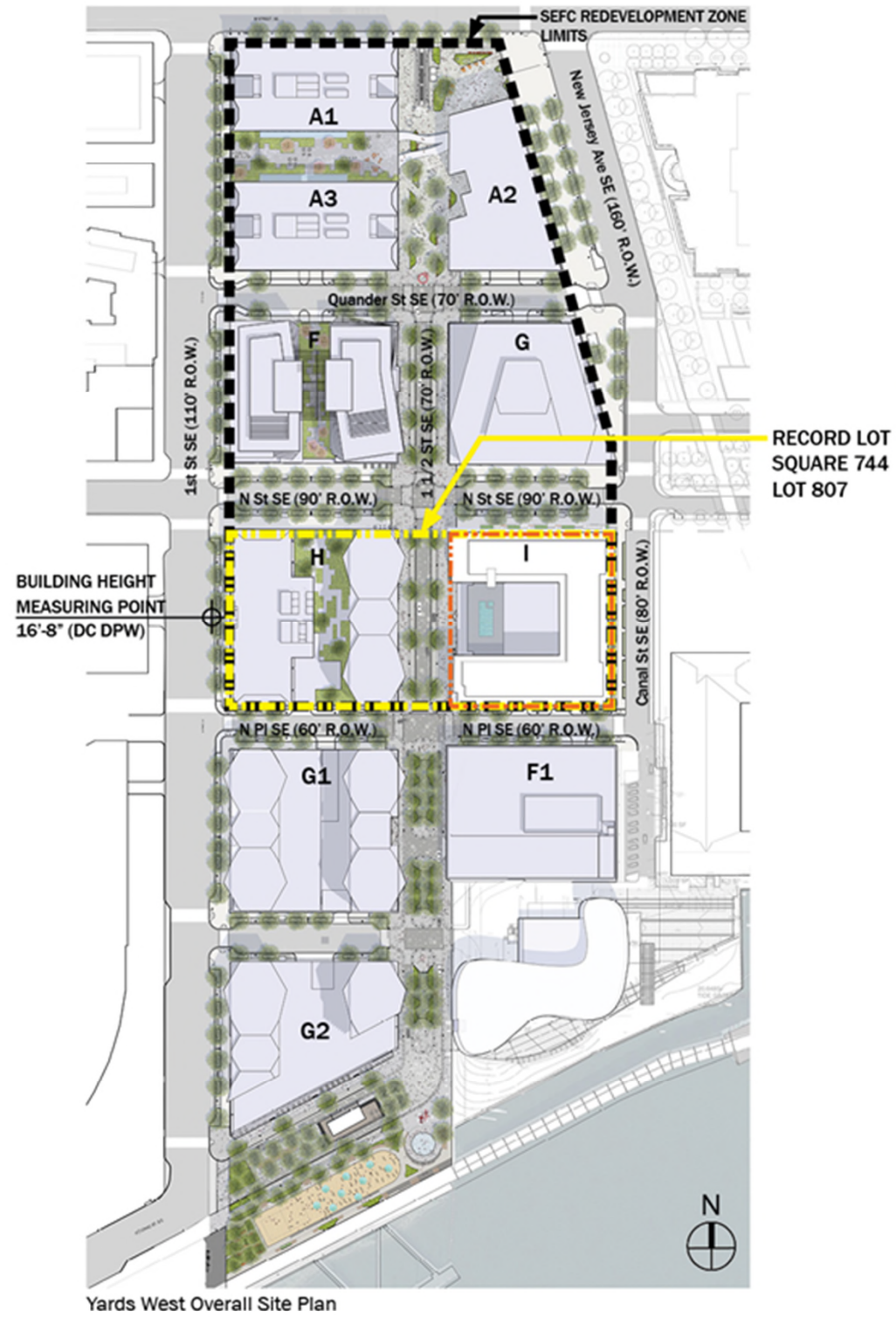

Parcel I Site Plan

Parcel I at The Yards West - Design Review Application

April 11th, 2019

Parcel i

Building Concept

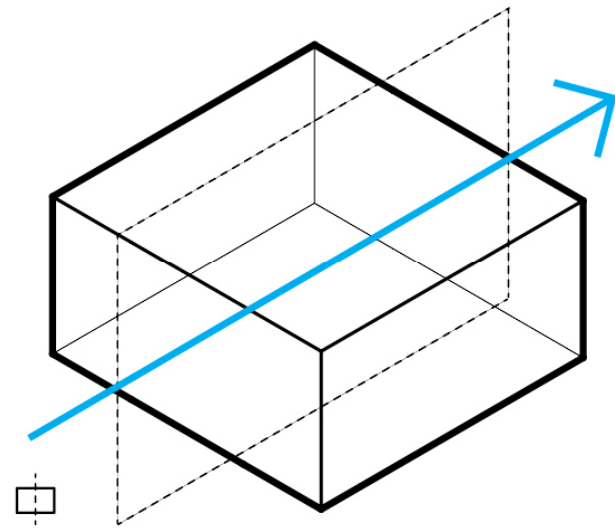

Full-block Volume

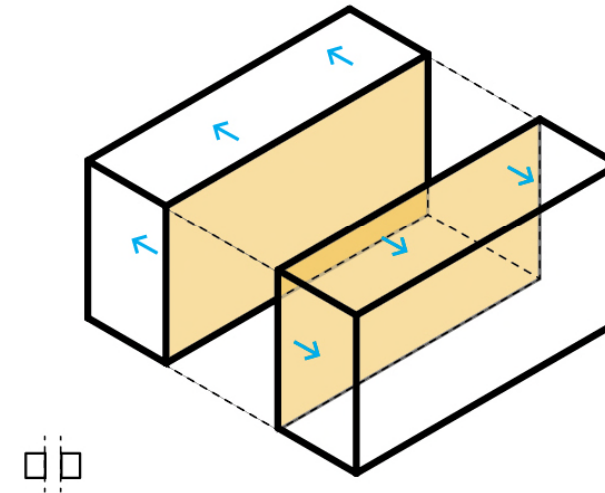

Volume splits into two (2) Bars to allow daylight and views to residential units

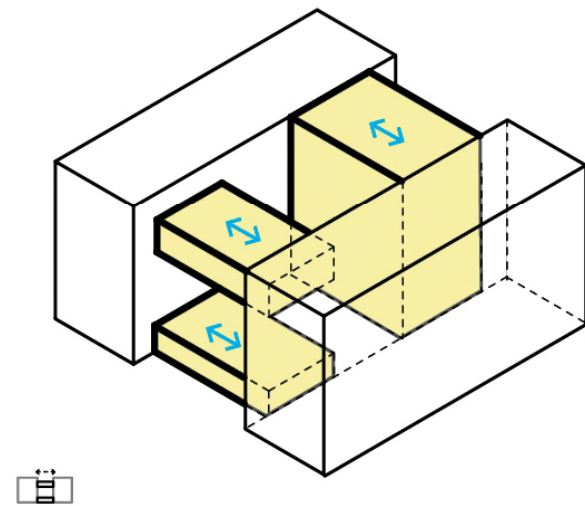

Link bars to unite building

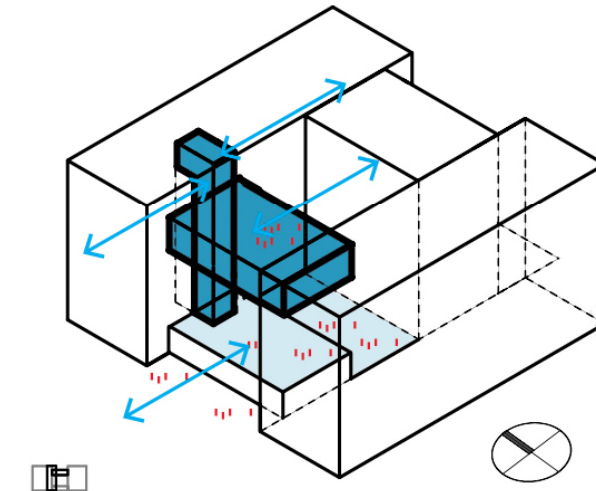

Vertical and horizontal connections to stimulate social interactions

Concept Diagrams

Parcel I at The Yards West - Design Review Application

April 11th, 2019

Parcel i

Design Proposal



Aerial Perspective - View Towards Southeast
Parcel I at The Yards West - Design Review Application

April 11th, 2019

Brookfield
Properties

Perkins Eastman DC

MPEP

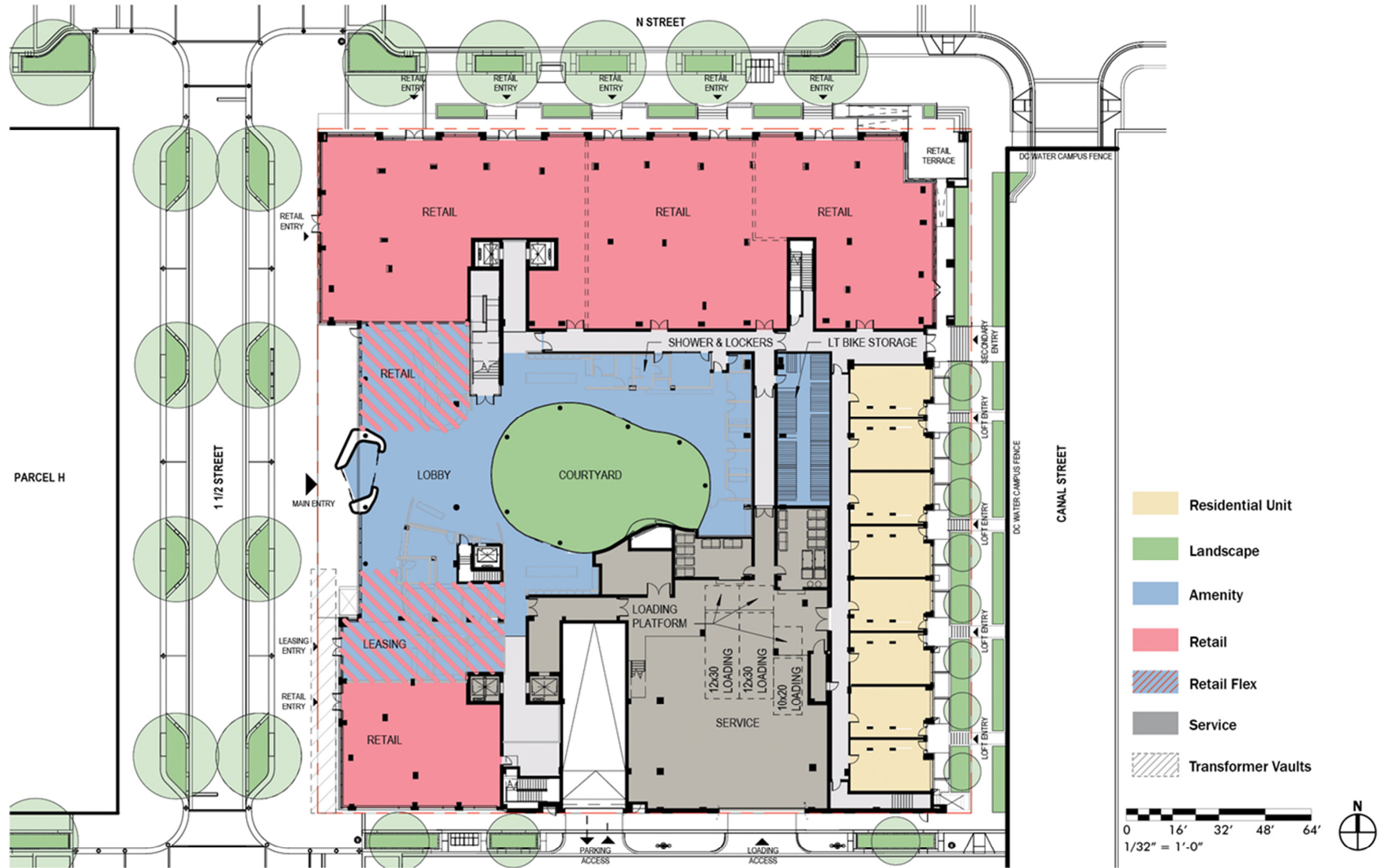

Floor Plan - Level 1

Parcel I at The Yards West - Design Review Application

April 11th, 2019

- Residential Unit
- Landscape
- Service

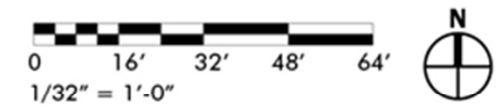
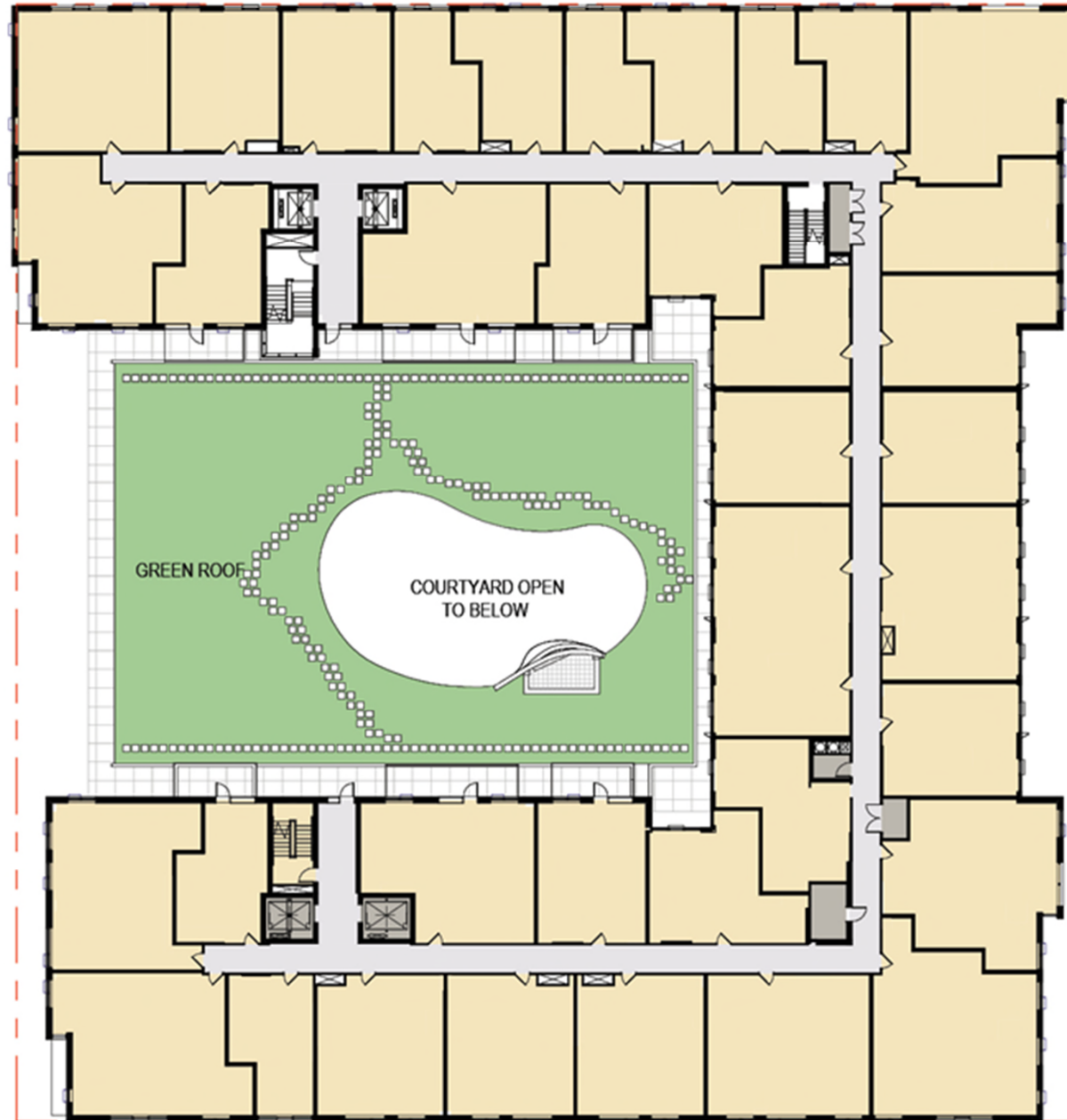

Floor Plan - Level 2
 Parcel I at The Yards West - Design Review Application

April 11th, 2019

- Residential Unit
- Service

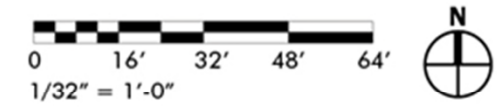
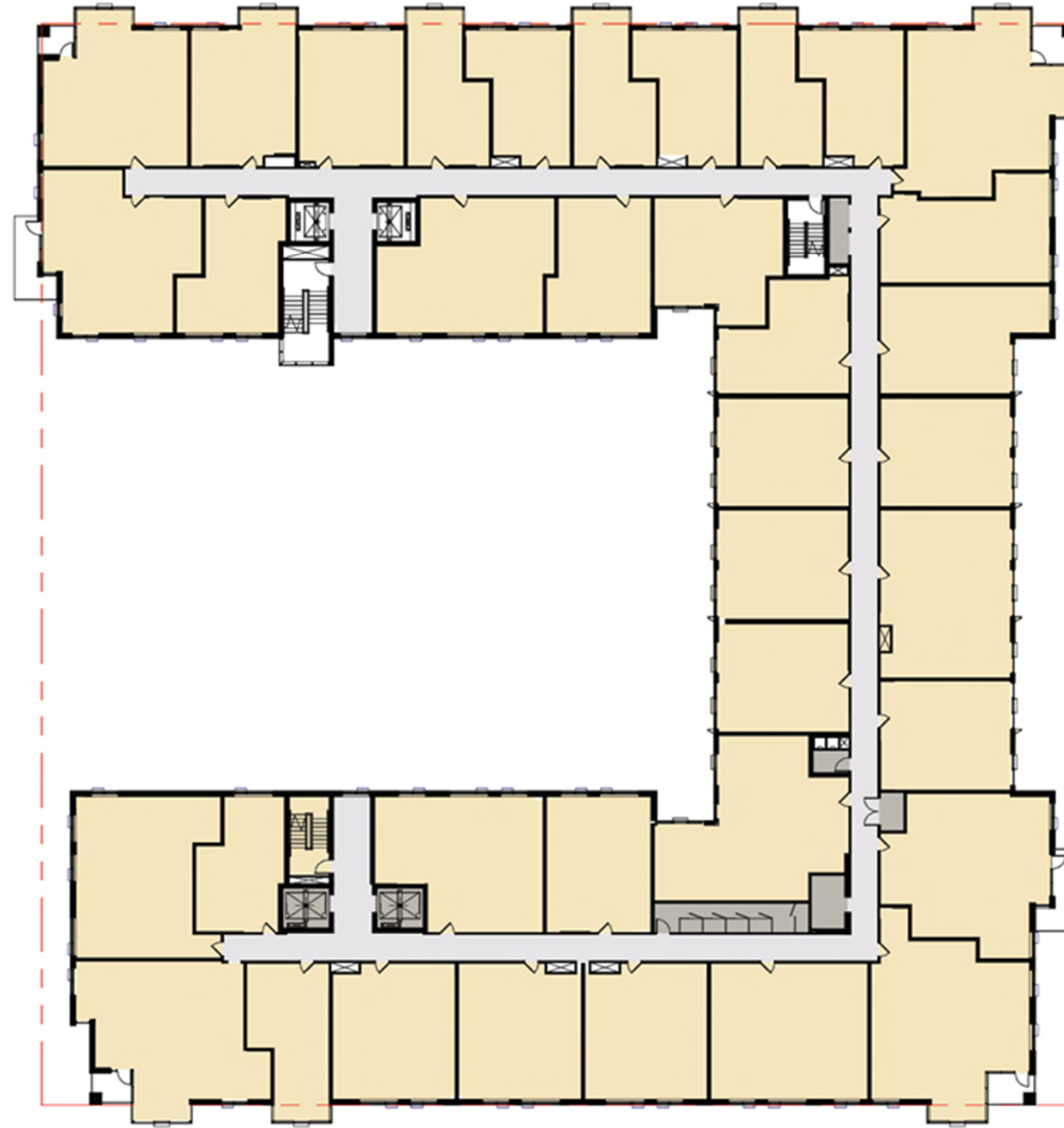

Floor Plan - Level 3-7
 Parcel I at The Yards West - Design Review Application
 April 11th, 2019

- Residential Unit
- Amenity
- Service

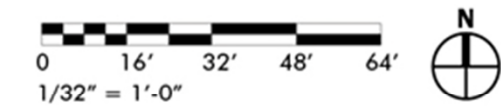
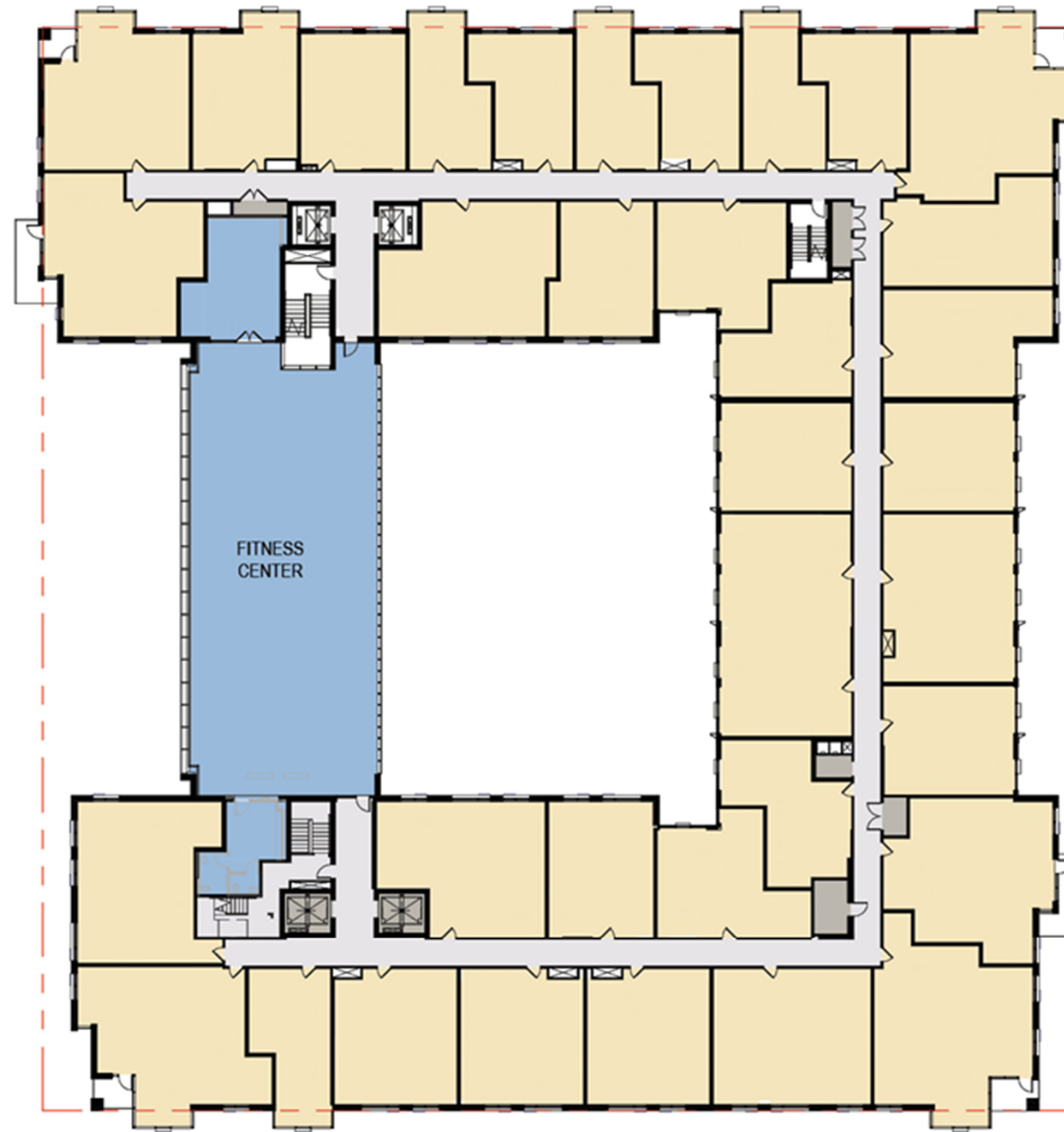

Floor Plan - Level 8
 Parcel I at The Yards West - Design Review Application

April 11th, 2019

Brookfield
 Properties

Perkins Eastman DC

MPEP

- Residential Unit
- Amenity
- Service

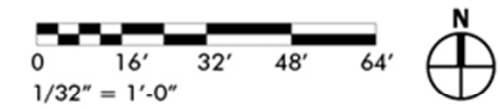
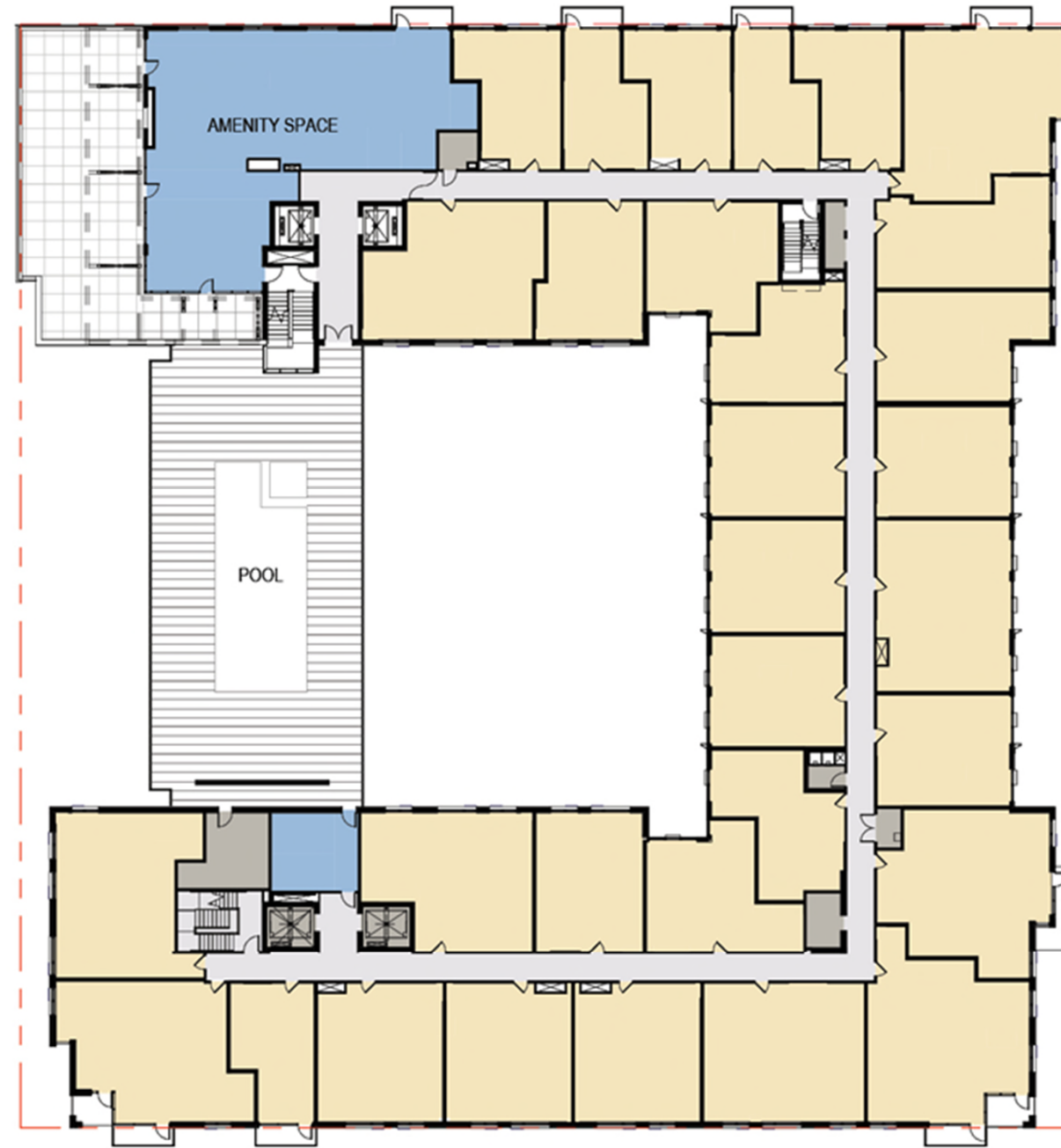

Floor Plan - Level 10
 Parcel I at The Yards West - Design Review Application
 April 11th, 2019

- Residential Unit
- Landscape
- Service

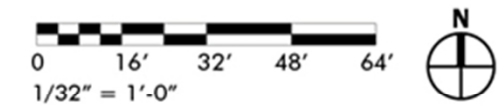
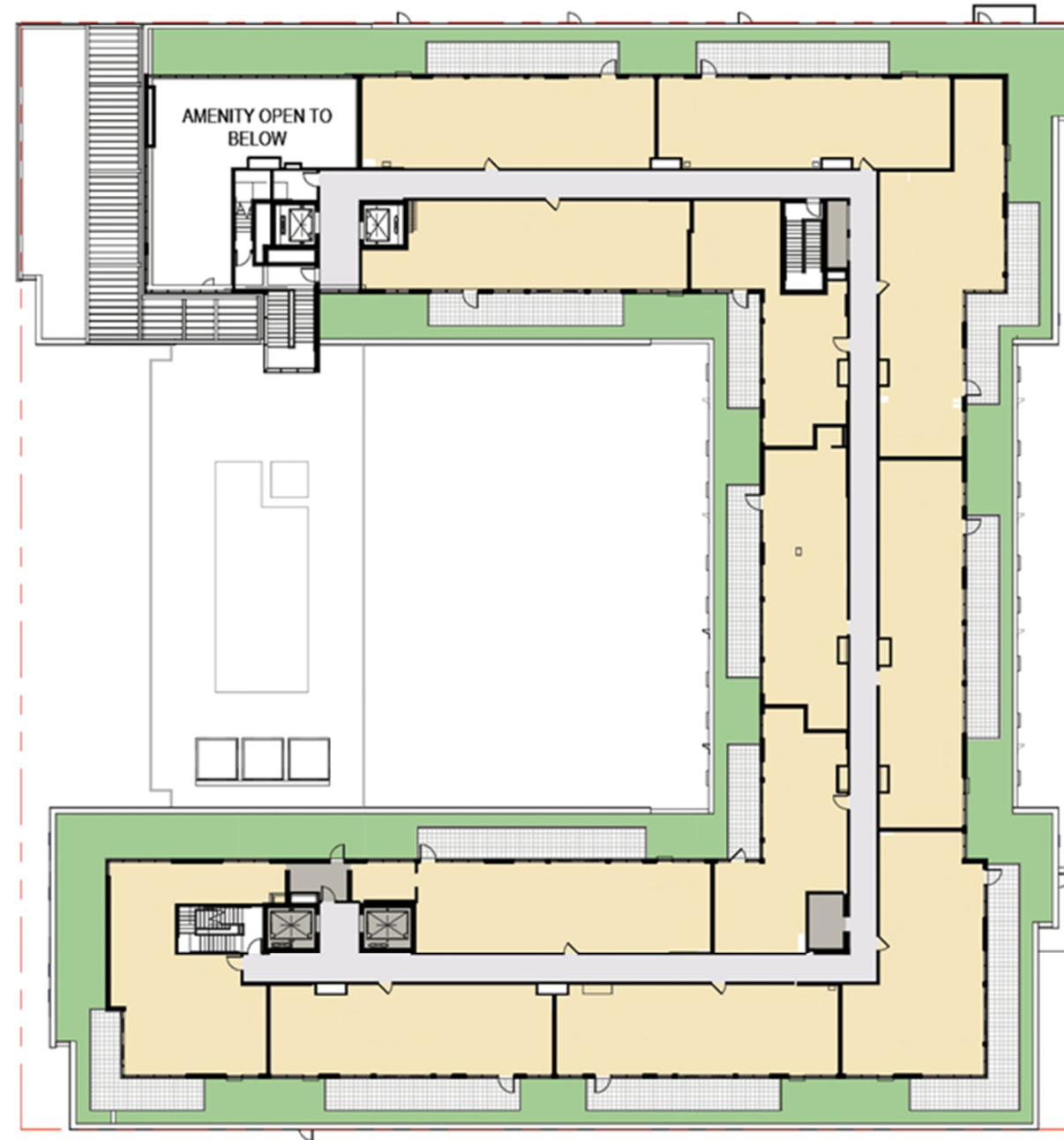

Floor Plan - Level 11 P.H.
Parcel I at The Yards West - Design Review Application

April 11th, 2019

Landscape (Below)

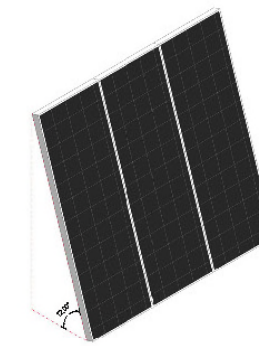
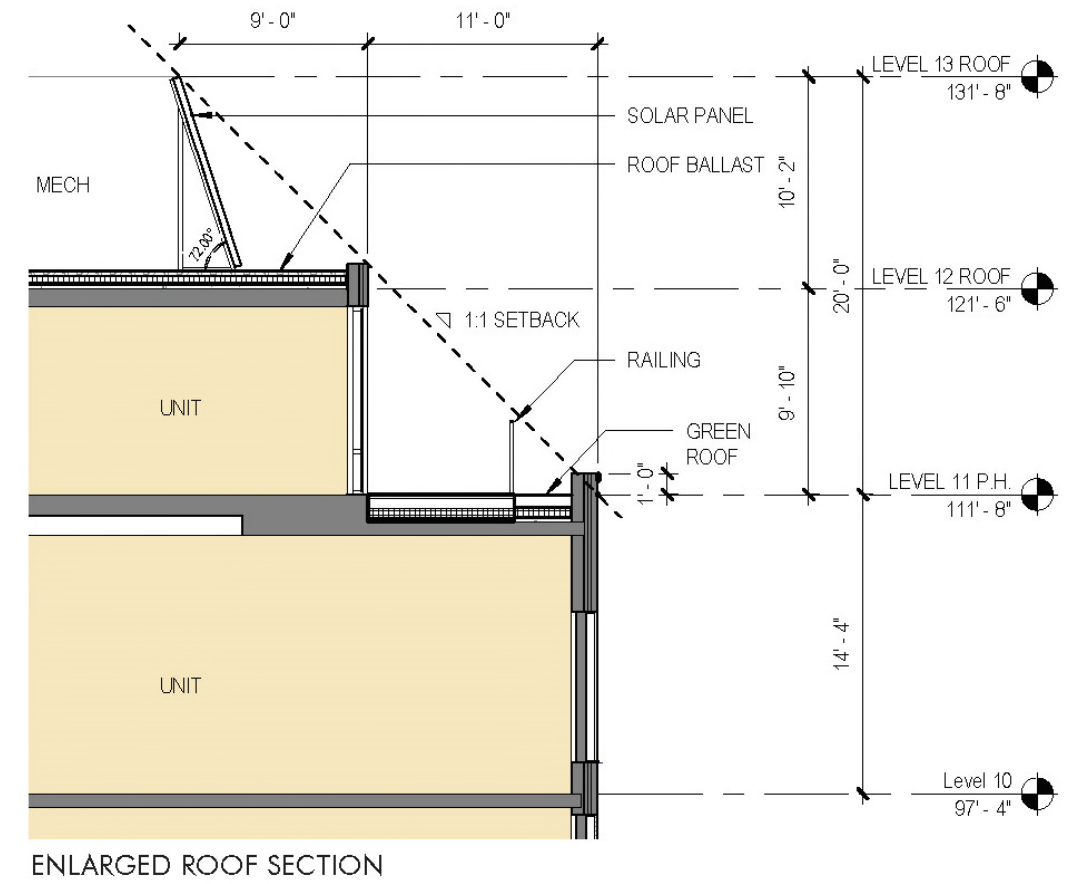
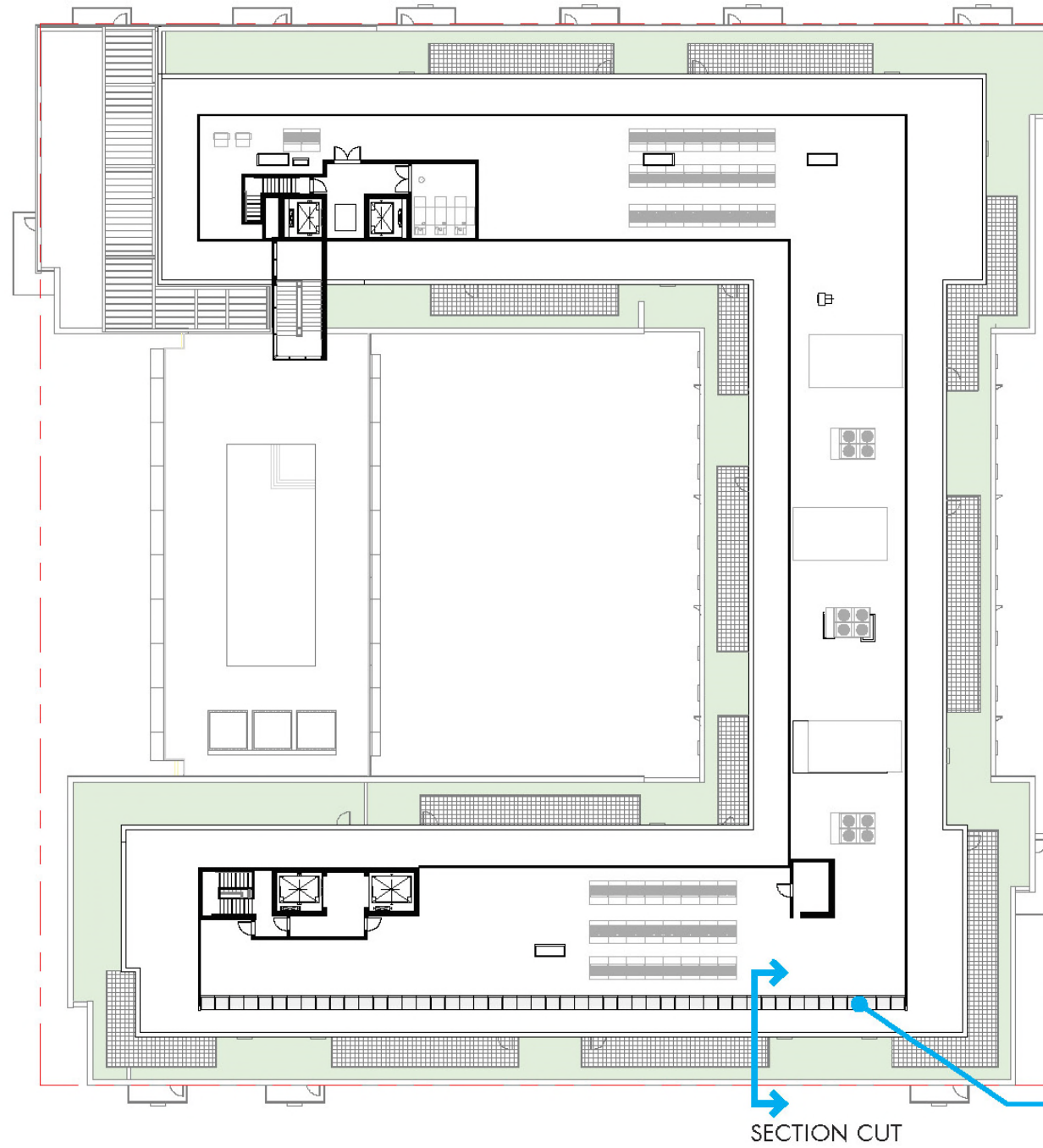

SOLAR PANELS
72° INSTALLATION AS
MECHANICAL SCREEN

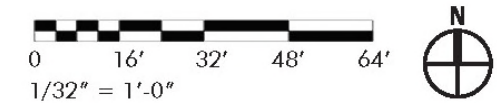

Floor Plan - Mechanical P.H.
Parcel I at The Yards West - Design Review Application

April 11th, 2019

Brookfield
Properties

Perkins Eastman DC

MPFP



Aerial View - Potential Solar Panel Zone
Parcel I at The Yards West - Design Review Application

April 11th, 2019

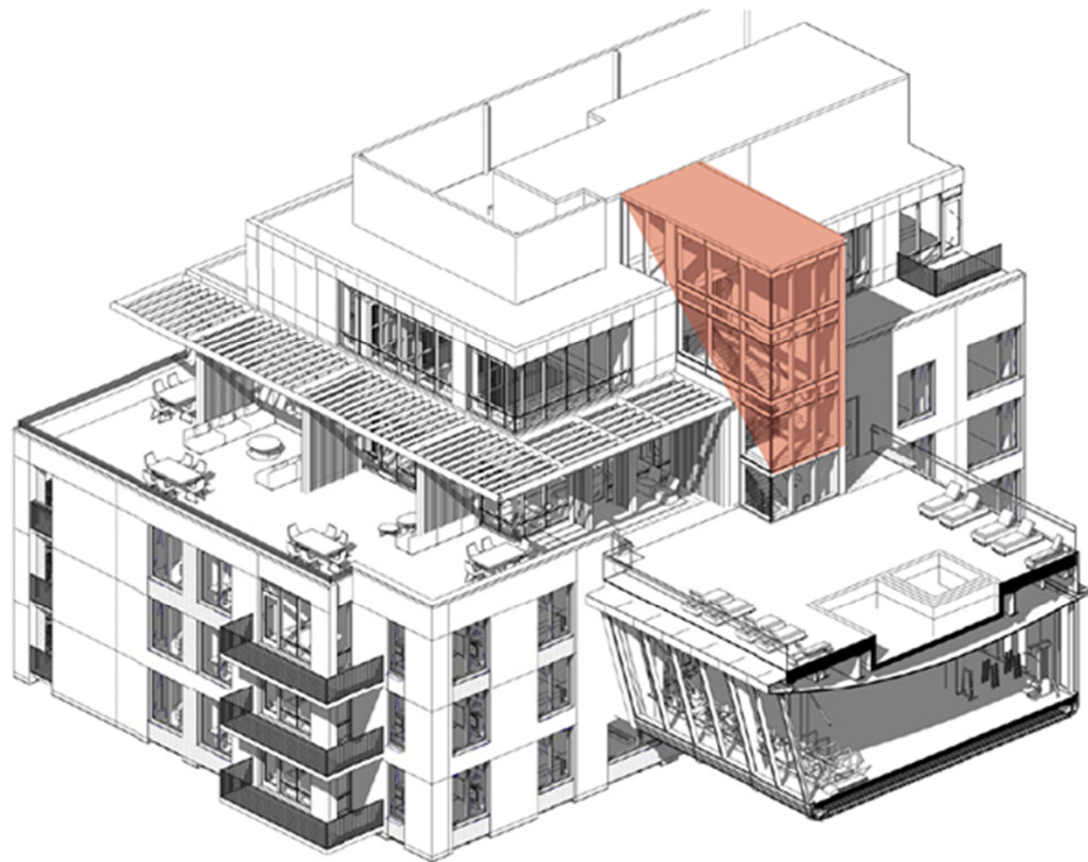

Roof Structure Relief - Axonometric View

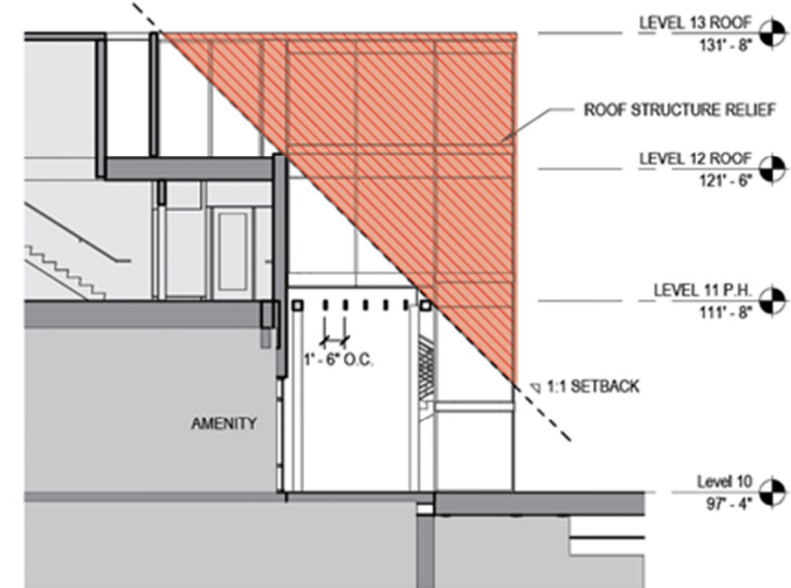

Roof Structure Relief - Section

Roof Structure Relief

Parcel I at The Yards West - Design Review Application

April 11th, 2019