

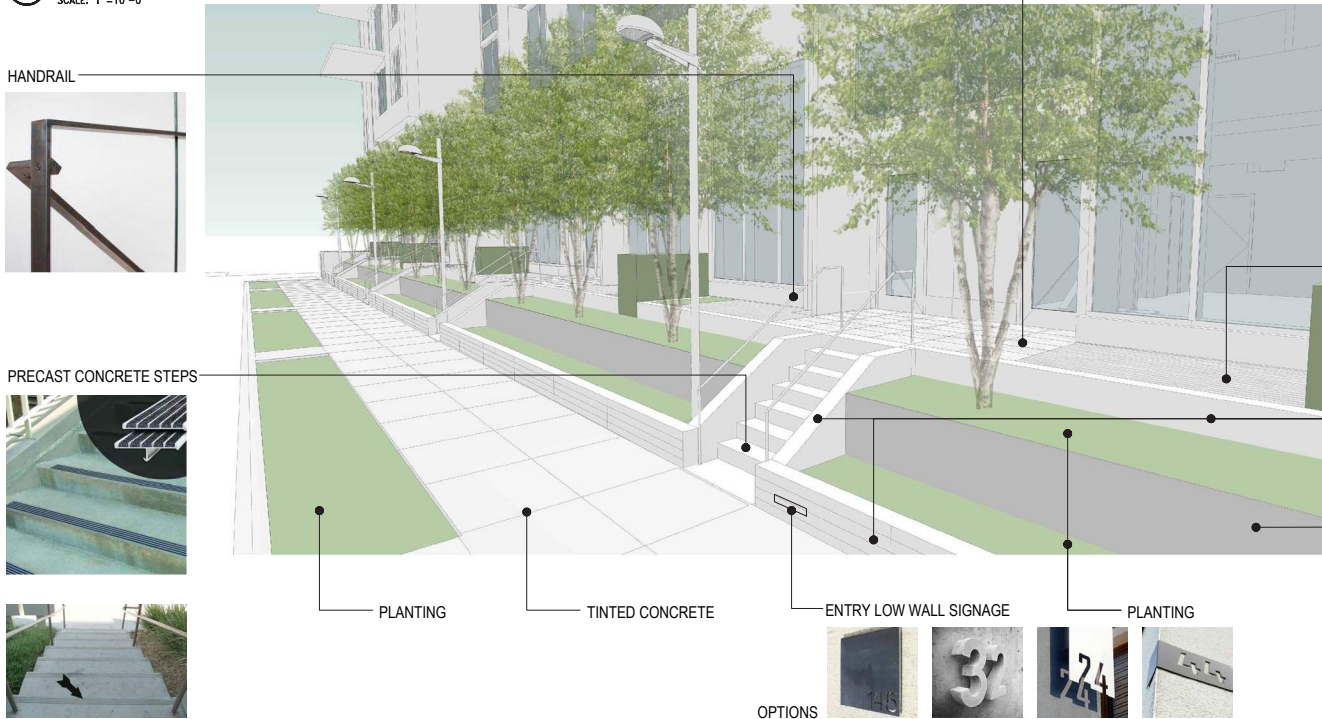

1 LOFT ENTRY ELEVATION @ SIDEWALK
SCALE: 1"=10'-0"



- PRECAST CONCRETE PAVERS**
 - PRIVATE TERRACE PAVERS - OPTION 1
MATERIAL: PRECAST CONCRETE
COLOR: PEWTER
FINISH: FLEKK
MFR: CONCRETE COLLABORATIVE
 - PRIVATE TERRACE PAVERS - OPTION 2
MATERIAL: PRECAST CONCRETE
COLOR: TAUPE
FINISH: FLEKK
MFR: CONCRETE COLLABORATIVE
- WOOD DECK**
 - NEW
 - WEATHERED
 - LOFT ENTRY PRIVATE TERRACE
MATERIAL: IPE WOOD DECK 3/4"x6" PREMIUM #1 PG
COLOR: NATURAL
FINISH: OIL BASED TRANSLUCENT PRODUCT
MFR: SEE SPECIFICATION
- FORMED CONCRETE WALL**
 - LOFT ENTRY WALL - OPTION 1
MATERIAL: FORMED CONCRETE
MFR: ARCHI + CONCRETE
 - LOFT ENTRY WALL - OPTION 2
MATERIAL: FORMED CONCRETE
COLOR: CEMENT QUARTZ
MFR: CERAMIC TECHNICS
- ALUMINUM PLANTER EDGE**
 - PLANTER EDGE - OPTION 1
MATERIAL: FLAT ALUMINUM OR STEEL
COLOR: CHROME II
FINISH: POWDER COAT
MFR: ORE DESIGNS INC.
 - PLANTER EDGE - OPTION 2
MATERIAL: FLAT ALUMINUM OR STEEL
COLOR: FLAT BLACK
FINISH: POWDER COAT
MFR: ORE DESIGNS INC.

Landscape - Canal St SE Loft Entry Elevation
Parcel I at The Yards West - Design Review Application

March 22nd, 2019

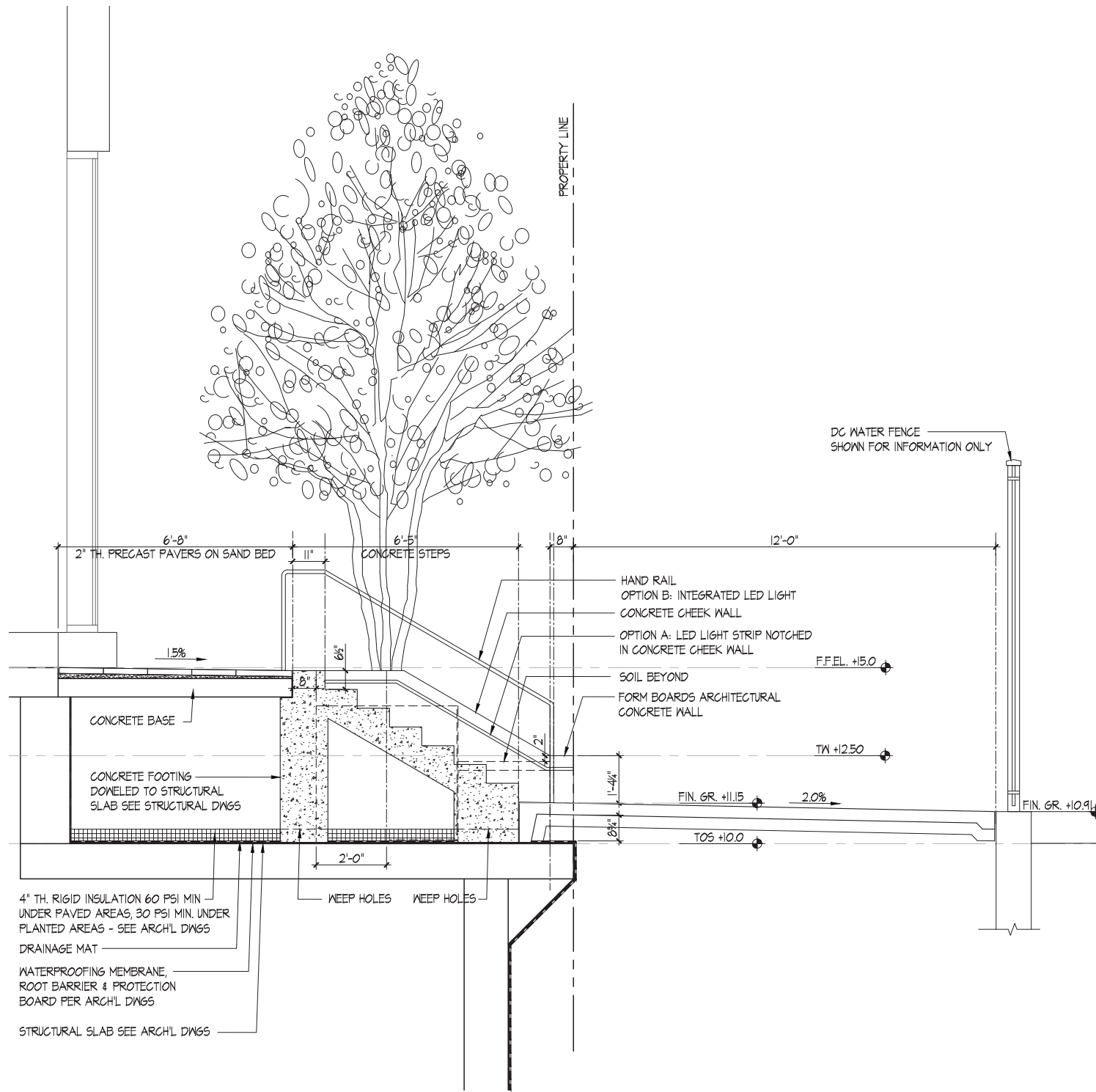

1 SECTION @ ENTRY STAIRS
SCALE: 1/4"=1'-0"

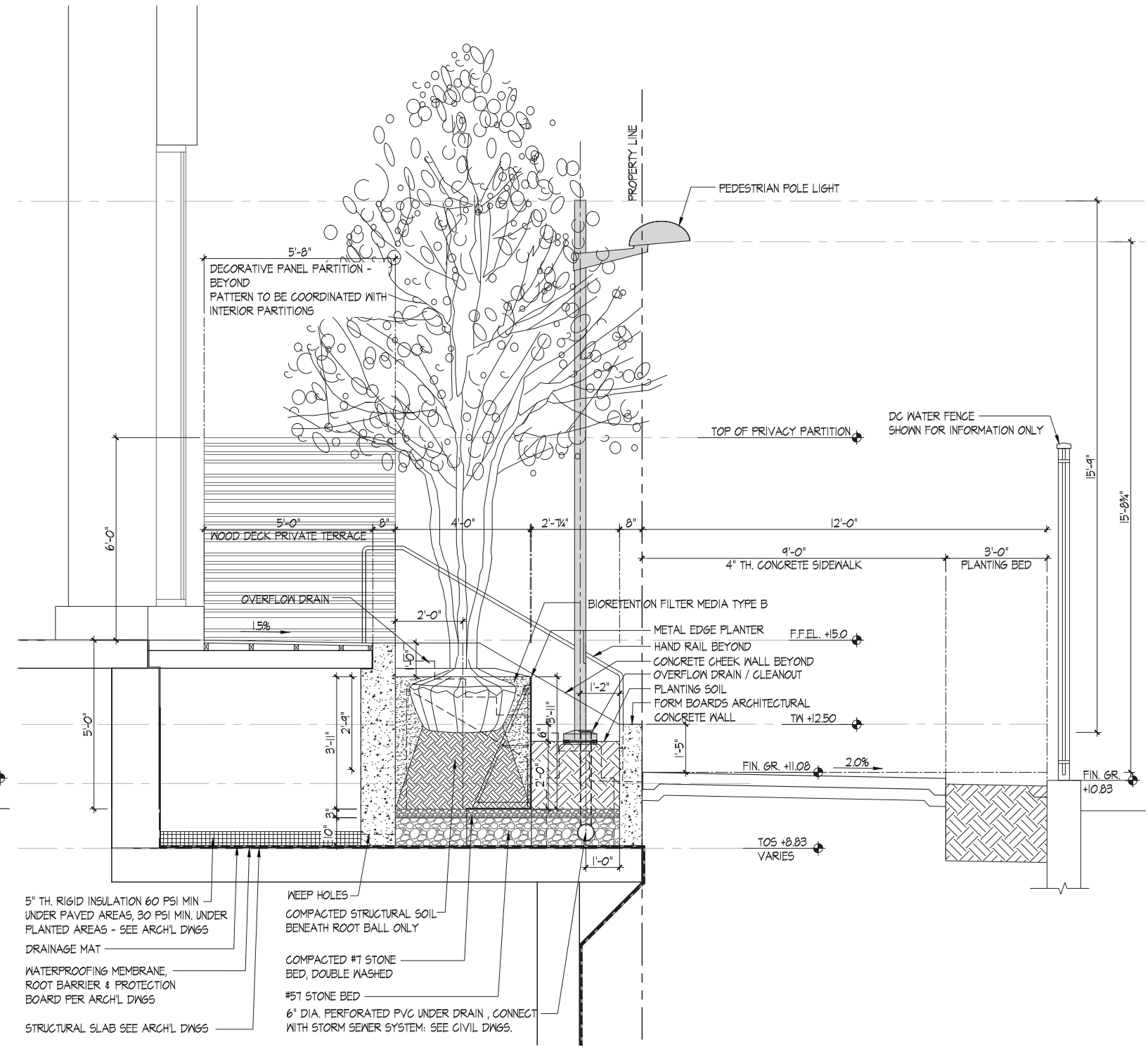

2 SECTION @ ENTRY WOOD DECK
SCALE: 1/4"=1'-0"

Section 8

Building Signage & Retail Storefronts

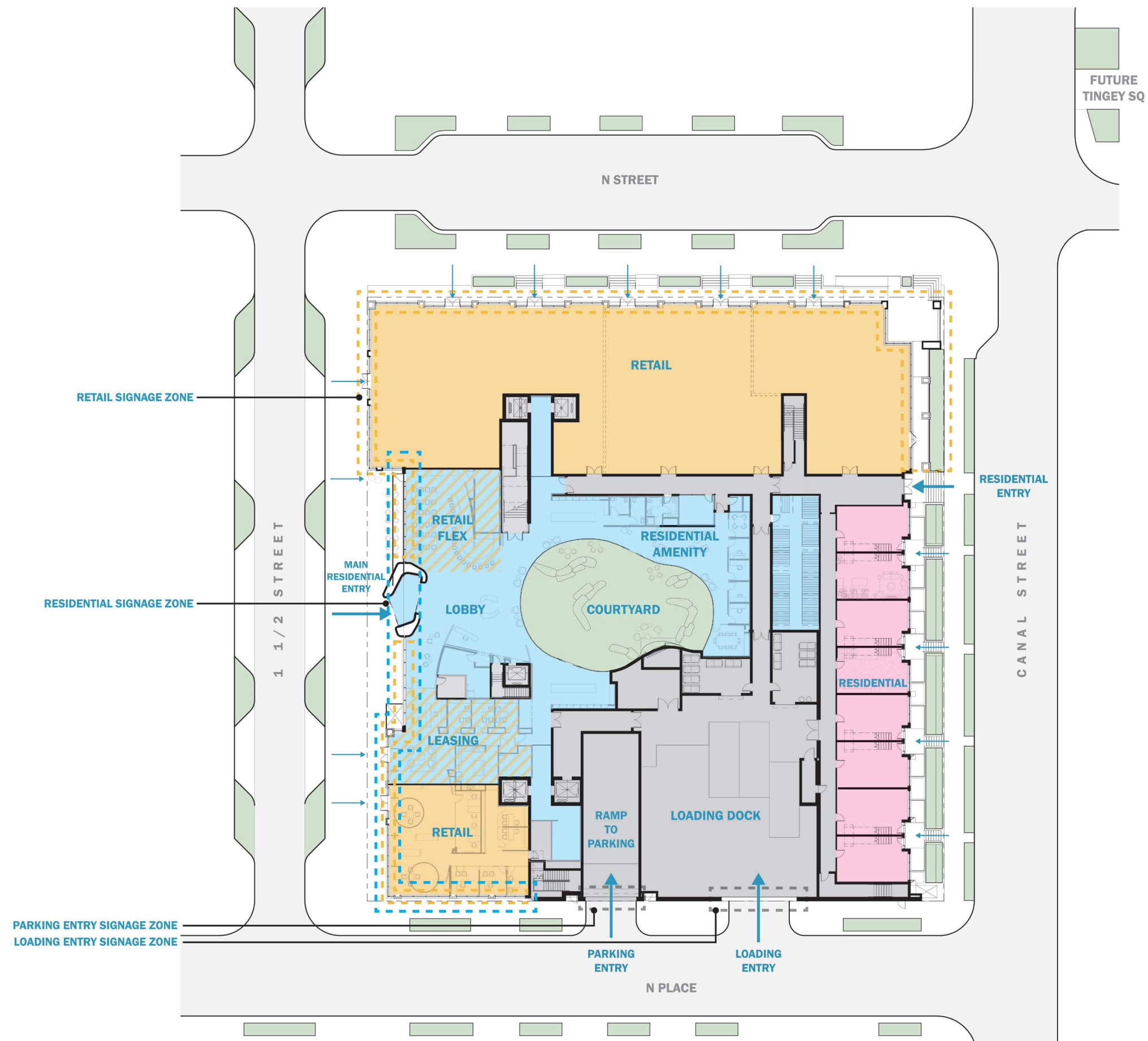

NOTE: INTERIOR PLAN LAYOUTS ARE CONCEPTUAL AND SHOWN FOR ILLUSTRATIVE PURPOSES ONLY. FINAL LAYOUT MAY VARY.

- RETAIL
- RESIDENTIAL AMENITY
- RESIDENTIAL
- RETAIL FLEX
- BACK OF HOUSE
- LANDSCAPE
- RETAIL SIGNAGE ZONE
- RESIDENTIAL SIGNAGE ZONE
- PARKING ENTRY SIGNAGE ZONE
- STOREFRONT ZONE

Concept Signage Location Plan
Parcel I at The Yards West - Design Review Application

March 22nd, 2019

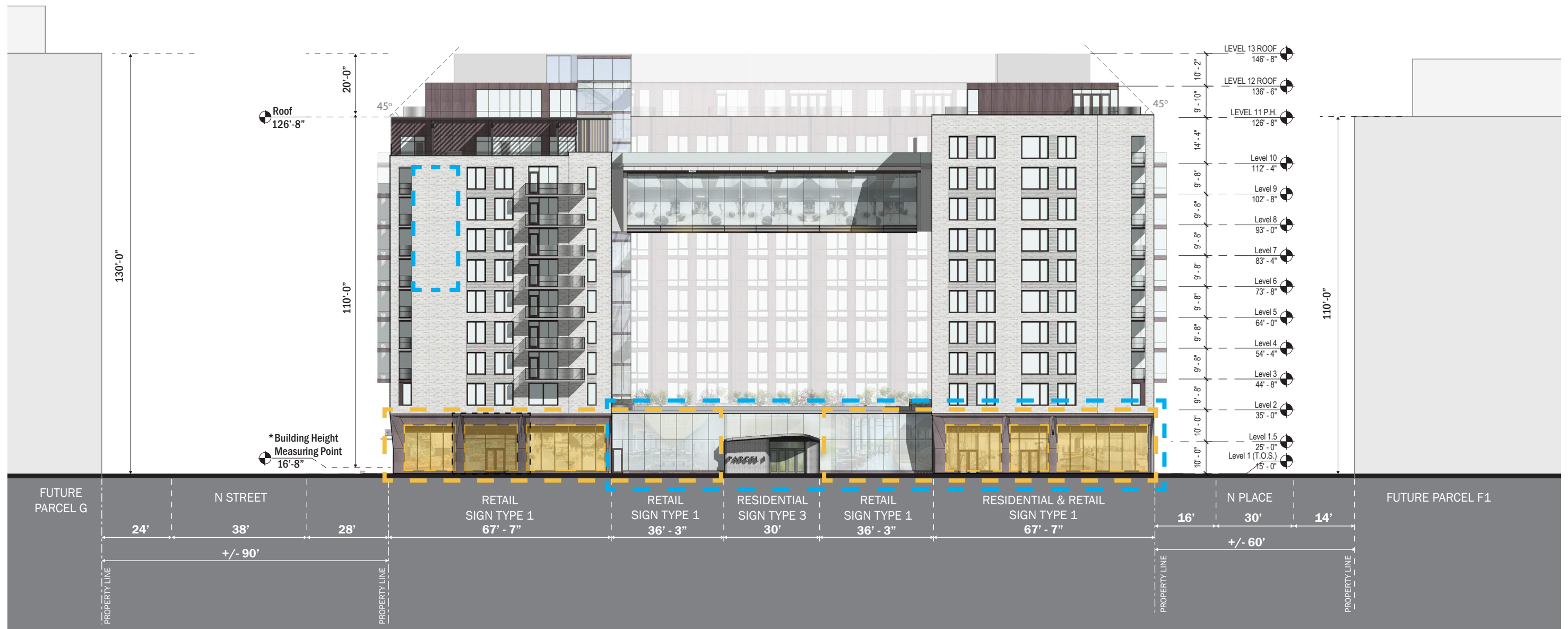
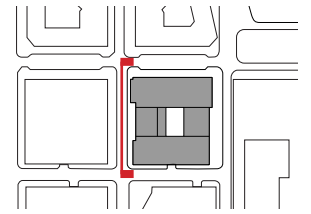

- RETAIL SIGNAGE ZONE
- RESIDENTIAL SIGNAGE ZONE
- PARKING ENTRY SIGNAGE ZONE
- STOREFRONT ZONE

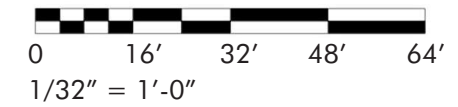

VERTICAL HEIGHTS: DC DPW DATUM

*BUILDING HEIGHT MEASURING POINT
TAKEN FROM 1ST STREET SE

Building Elevation - West

Parcel I at The Yards West - Design Review Application

March 22nd, 2019

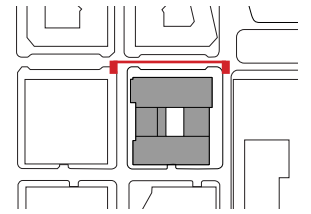

- RETAIL SIGNAGE ZONE
- RESIDENTIAL SIGNAGE ZONE
- PARKING ENTRY SIGNAGE ZONE
- STOREFRONT ZONE

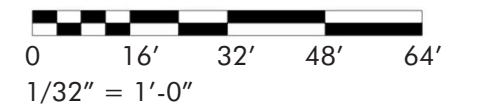

VERTICAL HEIGHTS: DC DPW DATUM

*BUILDING HEIGHT MEASURING POINT
TAKEN FROM 1ST STREET SE

Building Elevation - North

Parcel I at The Yards West - Design Review Application

March 22nd, 2019

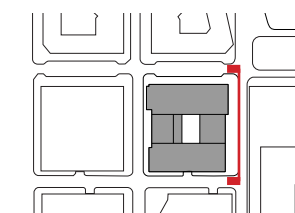

- RETAIL SIGNAGE ZONE
- RESIDENTIAL SIGNAGE ZONE
- PARKING ENTRY SIGNAGE ZONE
- STOREFRONT ZONE

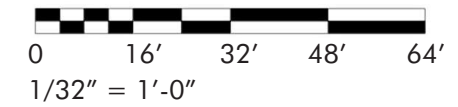

VERTICAL HEIGHTS: DC DPW DATUM

*BUILDING HEIGHT MEASURING POINT
TAKEN FROM 1ST STREET SE

Building Elevation - East

Parcel I at The Yards West - Design Review Application

March 22nd, 2019

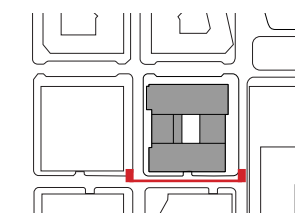

Building Elevation - South
 Parcel I at The Yards West - Design Review Application

March 22nd, 2019

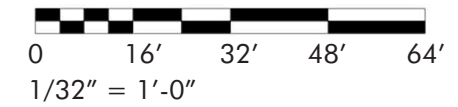

VERTICAL HEIGHTS: DC DPW DATUM

*BUILDING HEIGHT MEASURING POINT
 TAKEN FROM 1ST STREET SE

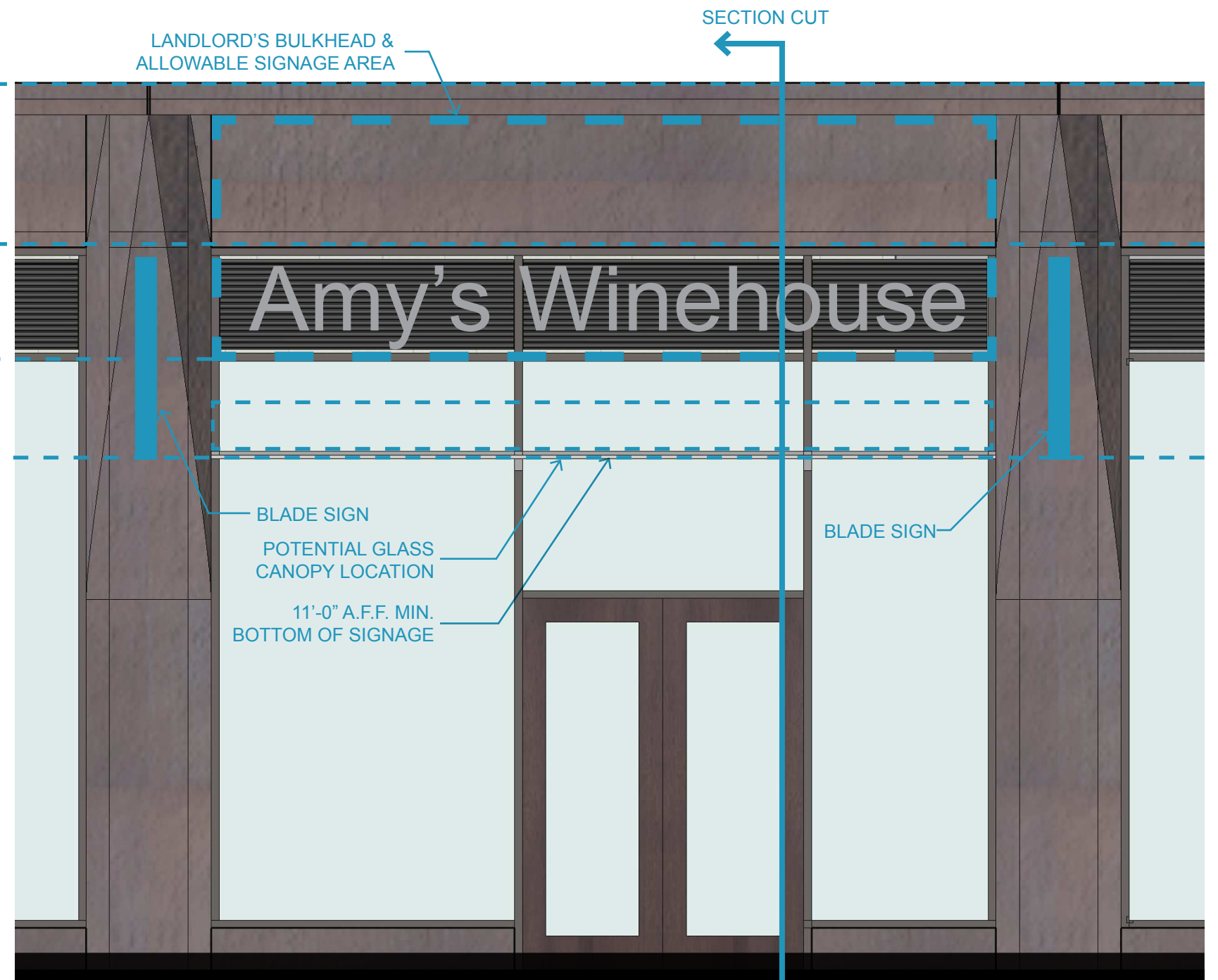
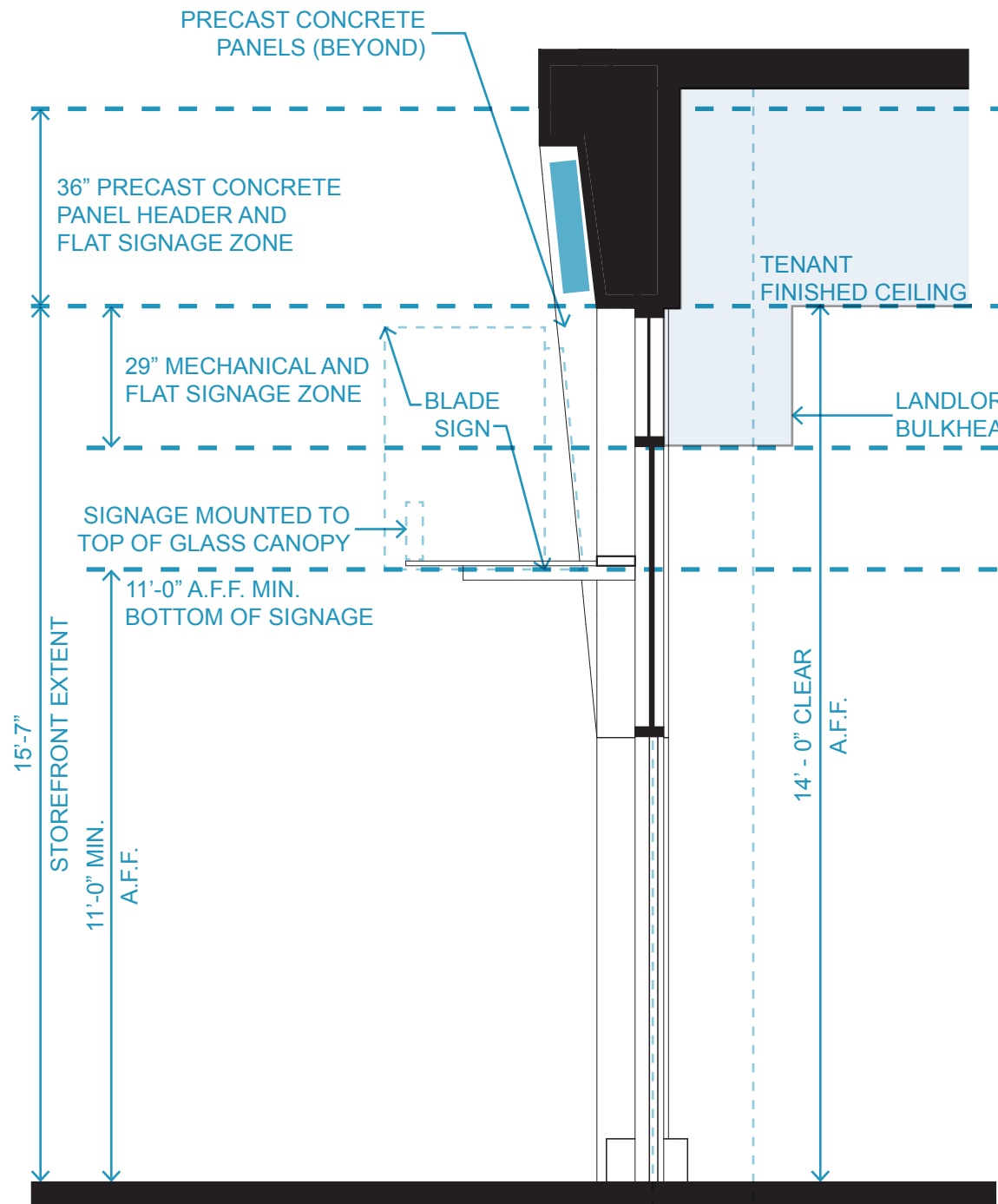

SECTION

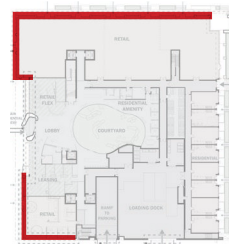

← SIDEWALK STORE →

1'-3" MAX
RECESSED STOREFRONT
ENTRY ZONE

ELEVATION

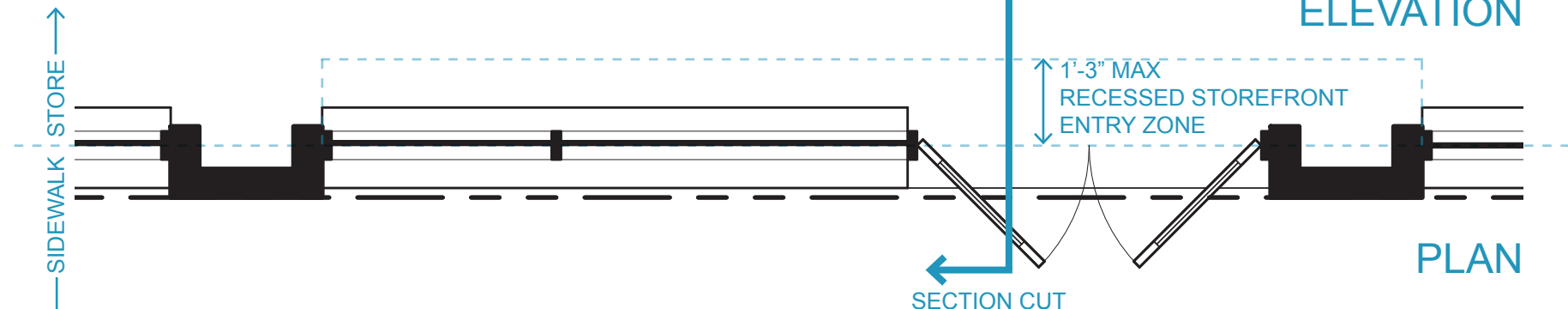

PLAN

Signage Guidelines - Typical Retail Signage

Parcel I at The Yards West - Design Review Application

March 22nd, 2019

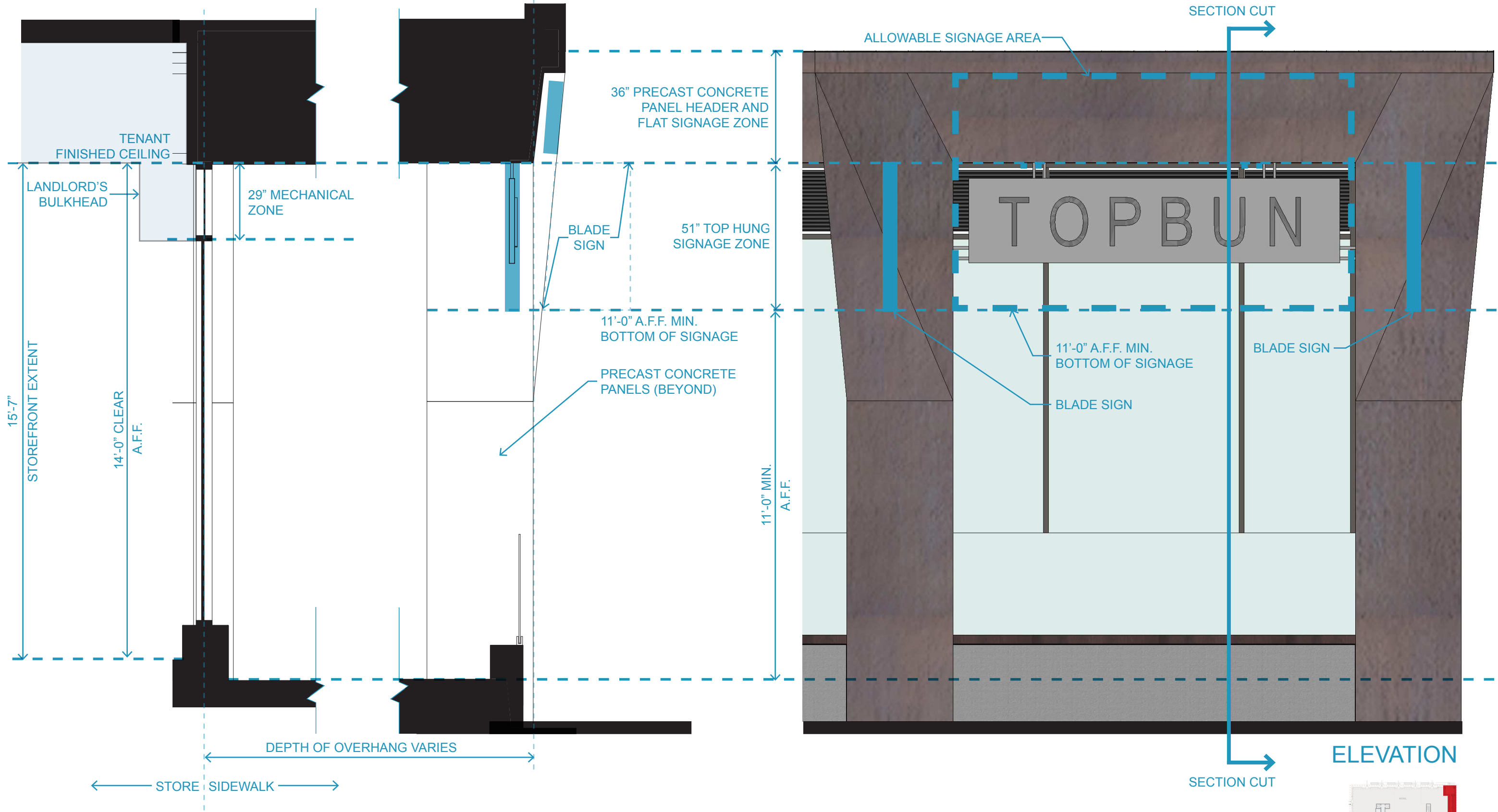

Signage Guidelines - Retail Signage at NE Corner
 Parcel I at The Yards West - Design Review Application

March 22nd, 2019

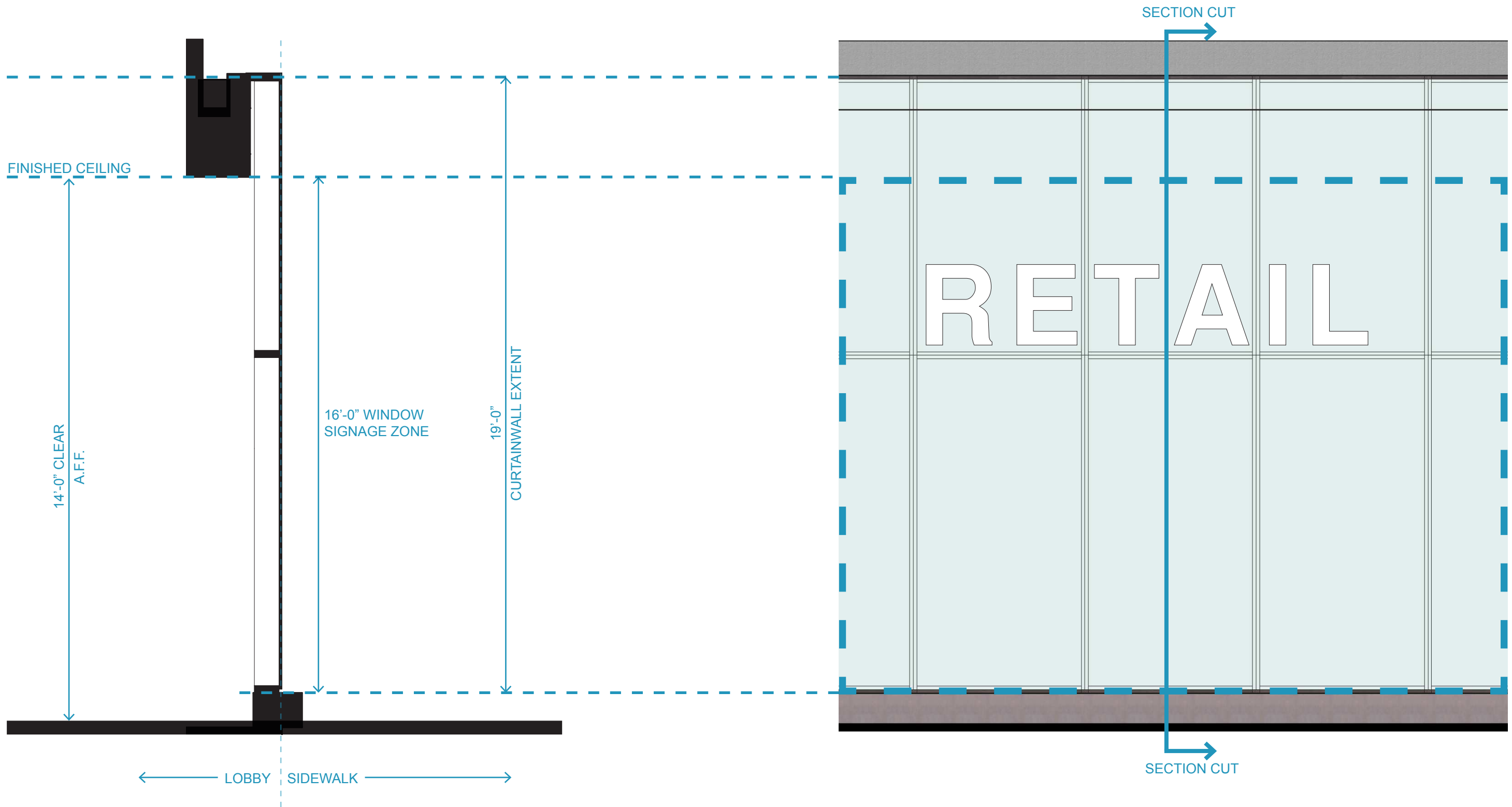

Signage Guidelines - Retail and Residential Signage at Lobby
 Parcel I at The Yards West - Design Review Application

March 22nd, 2019

SIGN TYPE 1
 TYPICAL RETAIL
 FLAT, BLADE, WINDOW, AND CANOPY



SIGN TYPE 2
 RETAIL AT NE CORNER
 CANOPY



Signage Guidelines - Signage Types

Parcel I at The Yards West - Design Review Application

March 22nd, 2019

SIGN TYPE 3
MAIN BUILDING SIGNAGE
FLAT



SIGN TYPE 4
PARKING AND LOADING
FLAT AND BLADE



Signage Guidelines - Signage Types

Parcel I at The Yards West - Design Review Application

March 22nd, 2019

GENERAL NOTES

THE SIGNAGE GUIDELINES PERMIT A VARIETY OF SIGNAGE AND STOREFRONT DESIGNS TO CONTRIBUTE TO THE LIVELINESS OF THE URBAN STREETScape AND PROVIDE APPROPRIATE IDENTIFICATION FOR RETAIL TENANTS.

- BUILDING SIGNS SHALL BE DESIGNED HOLISTICALLY AND COMPLIMENTARY TO THE ARCHITECTURAL SYTLE OF THE BASE BUILDING. SIGN LOCATIONS, SIZES, MESSAGES, FONTS, AND COLORS ARE EXPECTED TO BE CUSTOMIZED FOR EACH SPECIFIC TENANT, SUBJECT TO THESE GUIDELINES.
- ALL SIGNS SUBJECT TO LANDLORD REVIEW AND APPROVAL AS WELL AS ADHERENCE TO THESE GUIDELINES AND APPLICABLE CODE REQUIREMENTS. DRAWINGS AND SPECIFICATIONS MUST BE REVIEWED AND APPROVED BY THE LANDLORD PRIOR TO APPLICATION FOR BUILDING PERMITS AND OTHER RELATED APPROVALS.
- ALL SIGNS TO COMPLY WITH THE DC MUNICIPAL REGULATIONS SECTION N101.7, N101.9, N101.10, AND TITLE 12A SECTION 3107.
- IN ACCORDANCE WITH DCMR N101.10, ALL FIRST FLOOR SIGNS SHALL BE KEPT WITHIN A HEIGHT OF 20 FEET ABOVE THE SIDEWALK. FOR SIGNS ABOVE THE 20 FOOT HEIGHT, REFER TO TABLE N101.10.3.
- ILLUMINATED SIGNS ARE ONLY PERMITTED AT THE FIRST FLOOR. ALL ILLUMINATION MUST BE INTERNAL TO THE SIGN.

N101.7 **Types of signs.** The provisions of this section shall apply to types of signs and requirements for all signs subject to the provisions of Section N101.

N101.7.1 Projecting signs. Signs projecting from or beyond a building line or building restriction line shall be allowed in Commercial and Industrial Districts, as defined in the *Zoning Regulations*, when supported on iron or steel brackets and stayed securely, or affixed in an approved equivalent manner, subject to the limitations imposed by Sections N101.7.1.1 through N101.7.1.3.

N101.7.1.1 Sign projection restrictions. No sign shall project more than 42 inches (1067 mm) beyond the building line or building restriction line, on the street frontage of a building. Hooded lights are permitted to be placed on projecting signs solely to illuminate such signs, but the hoods of such lights shall not project more than an additional 6 inches (152 mm). No part of projecting signs shall have less than 8 feet (2438 mm) clearance above the surface of a sidewalk or any other space used by the public, nor less than 15 feet (4572 mm) clearance above the surface of any driveway in public space. No portion of a sign shall extend over public space closer than 18 inches (457 mm) from the curb lane. No sign, including illumination, shall project more than 6 inches (152 mm) beyond the building line, in alleys.

N101.9.6 Signs in Special Purpose Districts. For buildings or premises located in a Special Purpose District, as defined in the *Zoning Regulations*, the total area of signs subject to the provisions of Section N101 shall not exceed the limits set forth in Table N101.9.6, nor those imposed by any specific order of the Board of Zoning Adjustment or Zoning Commission.

TABLE N101.9.6
SIGNS IN SPECIAL PURPOSE DISTRICTS

STREET FRONTAGE (feet) ^a	MAXIMUM ALLOWABLE SIZE OF SIGN ON STREET FRONTAGE (square feet) ^b
Up to 40	40 ft ²
40 to 100	1 ft ² per foot of frontage
Over 100	100 ft ² plus 0.5 ft ² per foot of frontage over 100

N101.10 **Maximum size of signs.** In any district other than Residential or Special Purpose Districts, the total area of sign or signs subject to the provisions of Section N101 and attached to, displayed from, or erected upon any building, lot, or parcel of land, shall not exceed the limits prescribed in Sections N101.10.1 through N101.10.7.

N101.10.1 One story buildings. Two square feet (0.19 m²) for each foot of width of front of building occupied by the business or profession to be advertised, such signs or signs to be placed on the front under consideration within the limits of the portion of the front in which the business advertised is located. Roof signs shall not exceed 100 square feet (9.29 m²) facing any one street frontage.

N101.10.2 First floor stores or businesses in multi-story buildings. The provisions of Section N101.10.1 shall apply, except that such signs shall be kept within a height of 20 feet (6096 mm) above the sidewalk.

N101.10.3 Upper stories of multi-story buildings. The total area of all signs above the 20-foot height specified in Section N101.10.2 shall not exceed the limits set forth in Table N101.10.3, for each street frontage.

TABLE N101.10.3
SIGNS ABOVE THE FIRST STORY

AREA OF WALL ABOVE 20 FEET ABOVE THE SIDEWALK, ON STREET FRONTAGE (square feet) ^a	MAXIMUM ALLOWABLE AREA OF SIGNS ABOVE 20 FEET ABOVE SIDEWALK ON STREET FRONTAGE
Up to 1600	40 ft ²
1600 to 4000	1/40 of area of wall above 20 ft. height
Over 4000	100 ft ² roof signs, or 1/40 of area of wall above 20 ft. height for signs below roof

MAIN BUILDING SIGNAGE:

- MAIN BUILDING SIGNAGE CONVEYING INFORMATION SUCH AS BUILDING NAME, ADDRESS, AND LOCATION OF PARKING, LOADING, AND OTHER ENTRANCES SHALL BE LOCATED AS SHOWN IN THE GUIDELINES. SIGNS SHALL BE WALL-MOUNTED.
- MAIN BUILDING SIGNS MAY INCLUDE ILLUMINATION FOR BOTH DAY AND NIGHTTIME VISIBILITY. ALL EXTERNAL LIGHTING COMPONENTS, WIRES, JUNCTION BOXES, ETC MUST BE CONCEALED FROM VIEW.

RETAIL STOREFRONTS & SIGNAGE:

- STOREFRONT ZONES IDENTIFY LOCATIONS WHERE RETAIL TENANTS MAY INTEGRATE CUSTOM STOREFRONT DESIGN AND IDENTIFY GRAPHICS. STOREFRONTS SHOULD BE COMPLIMENTARY TO THE BUILDING ARCHITECTURE AND LIMITED TO THE ENVELOPE AS IDENTIFIED IN BUILDING ELEVATIONS WEST, NORTH, EAST, AND SOUTH. HIGH QUALITY AND DURABLE MATERIALS SUCH AS GLASS, WOOD, METAL, STONE, TERRACOTTA, TILE, ETC. ARE ENCOURAGED. ALL DETAILS ARE SUBJECT TO LANDLORD REVIEW AND APPROVAL AS WELL AS THESE GUIDELINES. DRAWINGS AND SPECIFICATIONS MUST BE REVIEWED AND APPROVED BY THE LANDLORD PRIOR TO APPLICATION FOR BUILDING PERMITS AND OTHER RELATED MATERIALS.
- PRIMARY RETAIL TENANT IDENTIFICATION SIGNAGE SHALL BE LOCATED WITHIN THE UPPER PORTION OF THE STOREFRONT ABOVE THE ENTRANCE AS SHOWN ON THE GUIDELINES. SIGNS SHALL BE WALL-MOUNTED IF INCORPORATED INTO THE STOREFRONT DESIGN.
- MAXIMUM HEIGHT OF TYPICAL RETAIL SIGNS TO BE 37 INCHES. THE MAXIMUM HEIGHT OF RETAIL SIGNAGE AT THE NORTHEAST CORNER OF THE BUILDING TO BE 55 INCHES.
- RETAIL TENANTS MAY ALSO INCORPORATE BLADE SIGNS AS SHOWN IN THE GUIDELINES. BLADE SIGNS ARE NOT TO PROJECT MORE THAN 42 INCHES BEYOND THE BUILDING PROPERTY LINE. THE BOTTOM OF THE BLADE SIGN MUST BE AT A MINIMUM OF 11 FEET ABOVE FINISHED FLOOR, AS SHOWN IN THE GUIDELINES.
- RETAIL SIGNS MAY INCLUDE ILLUMINATION FOR BOTH DAY AND NIGHTTIME VISIBILITY. ALL EXTERNAL LIGHTING COMPONENTS, WIRES, JUNCTION BOXES, ETC MUST BE CONCEALED FROM VIEW.
- LETTERS AND GRAPHICS MAY INCLUDE DEPTH, TEXTURE, AND DIMENSIONAL QUALITIES TO CREATE A DIVERSE, AUTHENTIC AND CREATIVE ENVIRONMENT.

WINDOW SIGNS:

- SECONDARY RETAIL IDENTIFICATION AND INFORMATIONAL SIGNS SHALL BE PERMITTED WITHIN THE STOREFRONT AND LOBBY AREAS.
- MULTIPLE SIGNS PERMITTED WITHIN WINDOWS, SUBJECT TO LANDLORD REVIEW AND APPROVAL. RETAIL TENANT GRAPHICS AND IDENTIFICATION FEATURES SHALL BE PERMITTED TO EXCEED MAXIMUM HEIGHT.

PROHIBITED SIGNS

ILLUMINATED SIGN BOXES

SIGNS WITH TAG LINES, SLOGANS, PHONE NUMBERS, SERVICE DESCRIPTIONS, OR ADVERTISING.

SIGNS MADE WITH PLASTIC, PLEXIGLAS, LEXAN, OR ACRYLIC, TRANSLUCENT OR OPAQUE.

MONUMENT STYLE SIGNAGE.

TEMPORARY SIGNAGE.

INTERNALLY ILLUMINATED CANOPIES.

SIGNS WITH EXPOSED RACEWAY, CONDUIT, JUNCTION BOXES, TRANSFORMERS, VISIBLE LAMPS, TUBING, OR NEON CROSSOVERS OF ANY TYPE.

ROTATING, ANIMATED, OR FLASHING SIGNS.

POLE SIGNS AND OTHER SIGNS WITH EXPOSED STRUCTURAL SUPPORTS NOT INTENDED AS A DESIGN ELEMENT EXCEPT FOR CODE REQUIRED SIGNS.

PENNANTS, BANNERS, OR FLAGS IDENTIFYING INDIVIDUAL TENANTS.

SIGNS ATTACHED, PAINTED, OR OTHERWISE AFFIXED TO AWNINGS, TENTS, OR UMBRELLAS, HOWEVER SUCH SIGNS MAY BE PERMITTED IN CONJUNCTION WITH SPECIAL DESIGN REVIEW BY THE LANDLORD.

BALLOONS AND INFLATABLE SIGNS.

ANY SIGNS INCLUDING FREESTANDING SIGNS ADVERTISING THE AVAILABILITY OF EMPLOYMENT OPPORTUNITIES.

SIGNS WHICH EMIT SOUND, ODOR, OR VISIBLE MATTER OR WHICH BEAR OR CONTAIN STATEMENTS, WORDS OR PICTURES OF AN OBSCENE, PORNOGRAPHIC, OR IMMORAL CHARACTER.

FLUORESCENT OR REFLECTIVE SIGN COLORS.

SIMULATED MATERIALS, I.E. WOOD GRAINED PLASTIC LAMINATE, WALL COVERING, PAPER, CARDBOARD, OR FOAM.

ROOF TOP SIGNS.

Section 9

Public Space Steps & Ramps



N Street SE Steps and Ramps Exhibit
 Parcel I at The Yards West - Design Review Application

March 22nd, 2019