

BUILDING SECTION A-A

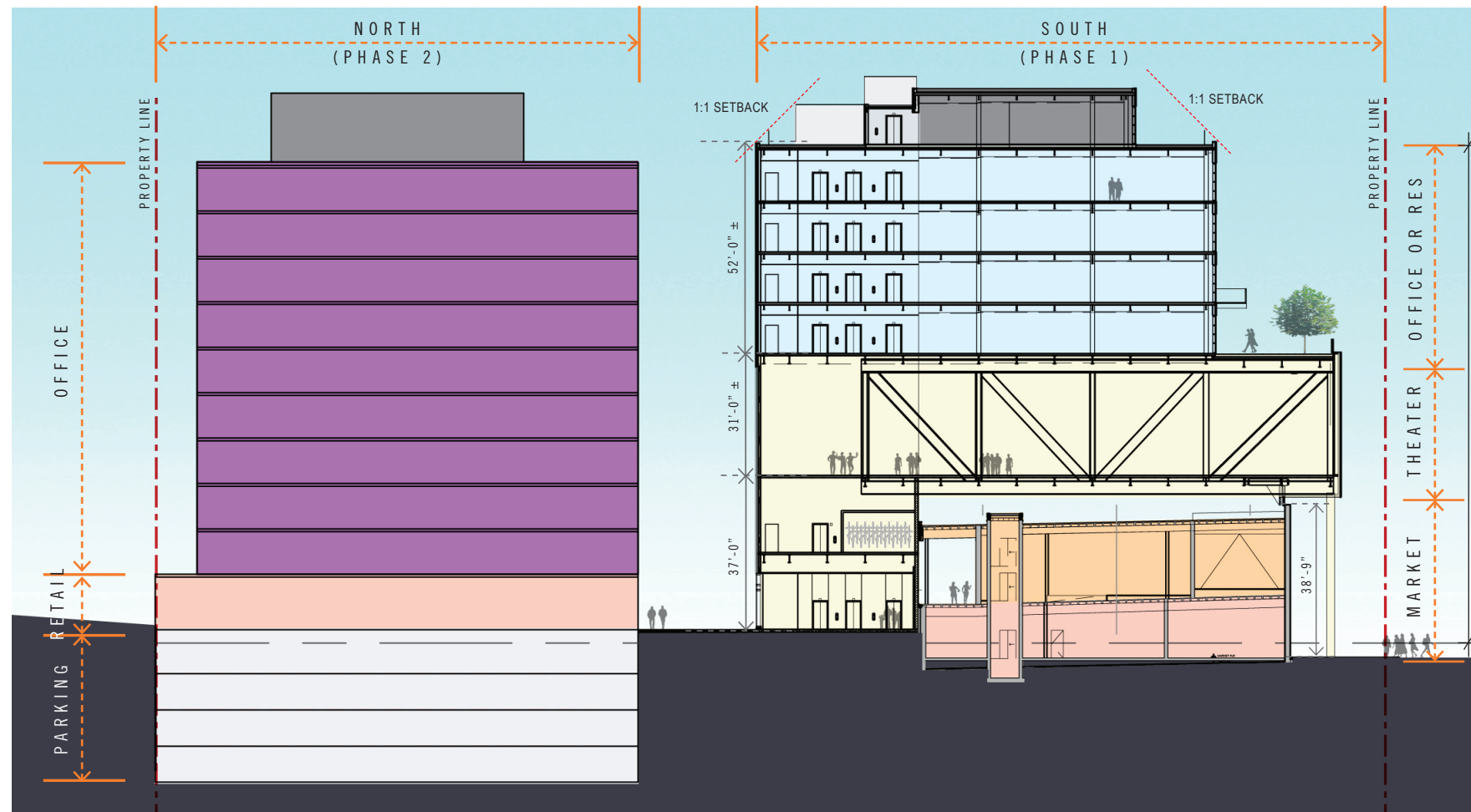

NOTES:

1. REFER TO ROOF PLAN FOR OVERALL BUILDING DIMENSIONS.
2. THE EXTERIOR ELEVATIONS, INCLUDING DOOR AND WINDOW SIZES, NUMBER, AND LOCATIONS, THE INTERIOR PARTITION LOCATIONS, THE NUMBER, SIZE, AND LOCATIONS OF THEATER BOXES, OUTDOOR SPACE, STAIRS, BALCONY, TERRACES, AND ELEVATORS ARE PRELIMINARY AND SHOWN FOR ILLUSTRATIVE PURPOSES ONLY. THE PARKING GARAGE LAYOUT IS SHOWN FOR ILLUSTRATIVE PURPOSES ONLY.
3. ALL SPOT ELEVATIONS ARE RELATIVE TO THE MEASURING POINT, ASSUMED FOR THESE DRAWINGS TO BE +0'-0".
4. ALL BALCONY LOCATIONS SHOWN ARE ILLUSTRATIVE; SIZE/ LOCATION ARE SUBJECT TO CHANGE.

LEGEND

- - - PROPERTY LINE
- CORE/ SERVICE
- RETAIL
- EVENT
- THEATER
- OFFICE OR RESIDENTIAL
- PARKING
- TERRACE
- ROOF
- OFFICE

BUILDING SECTION B-B

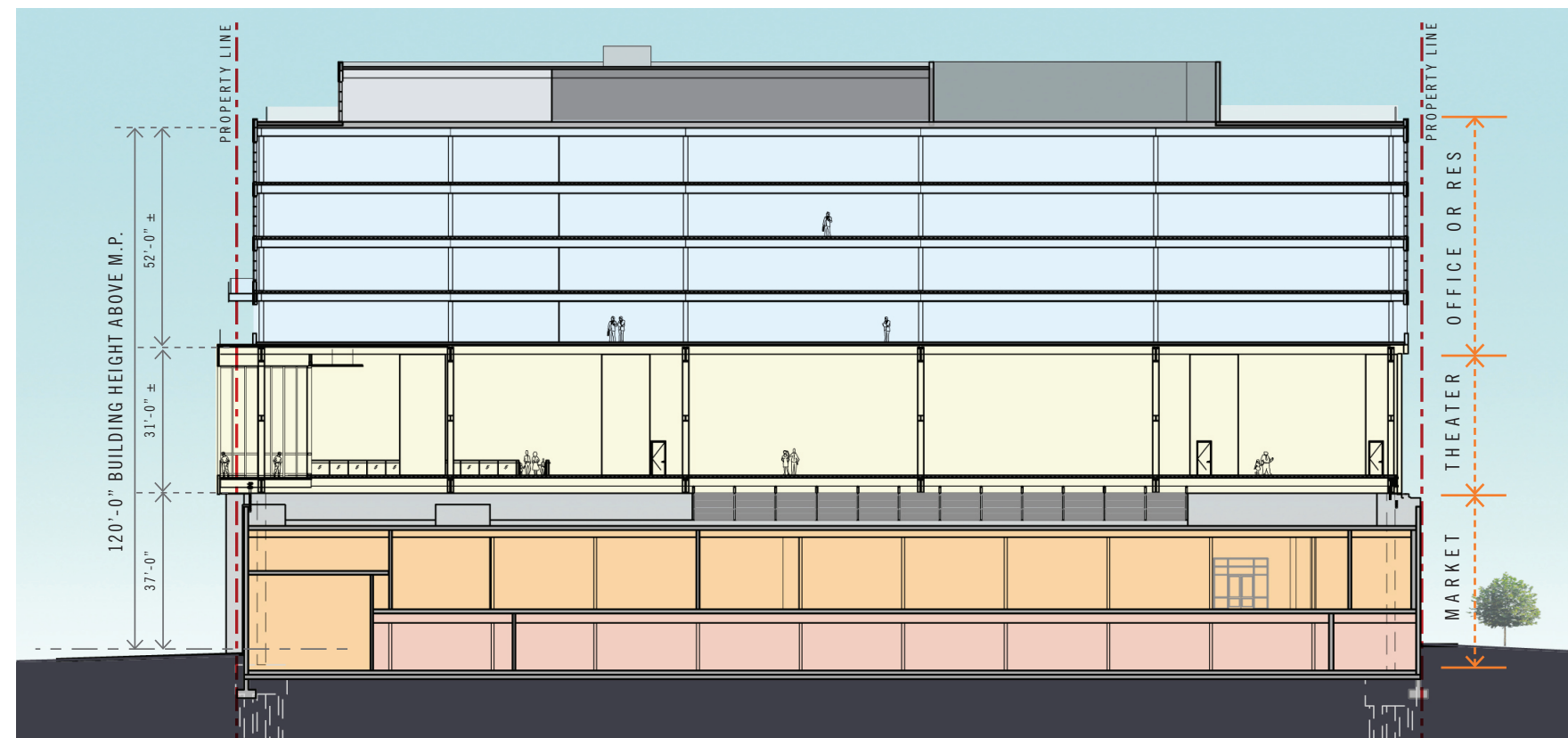

KEY PLAN

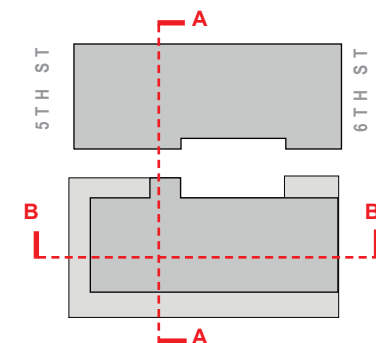

1309 - 1329 5TH STREET NE WASHINGTON, DC

PUD SUBMISSION 2014 JULY 3
(REVISED 2015 JANUARY 30)

OPTION 1 (NORTH BUILDING OFFICE OPTION)
BUILDING SECTIONS 1" = 40'

A 11

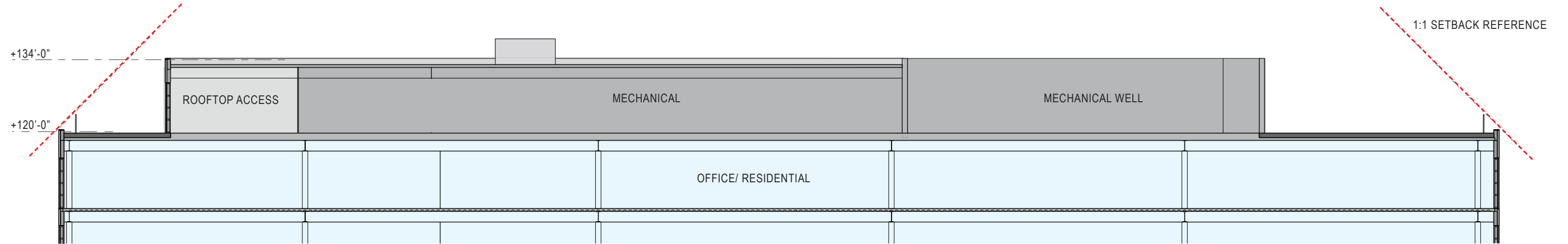

PARTIAL SECTION A-A

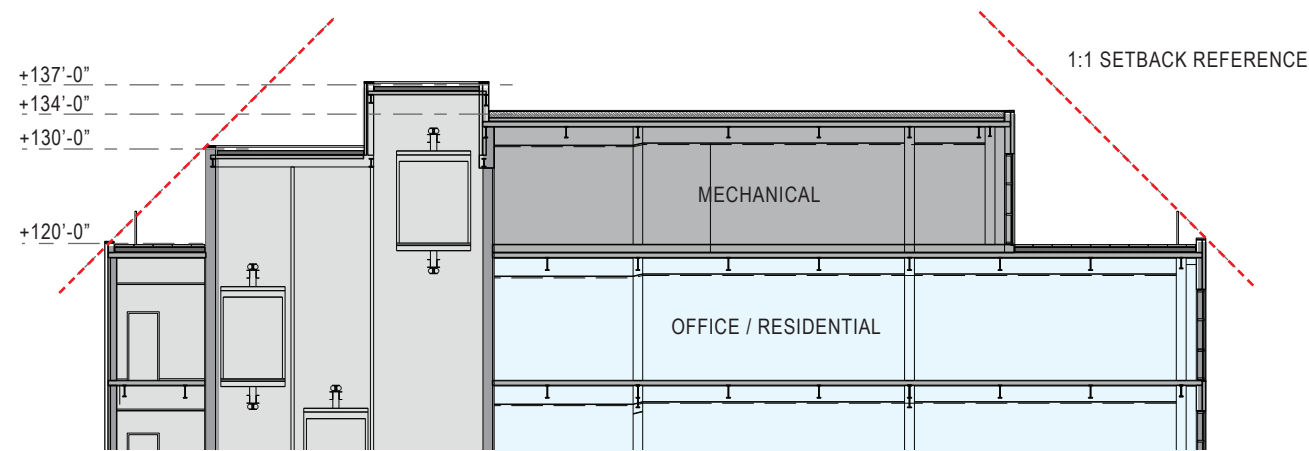

PARTIAL SECTION B-B

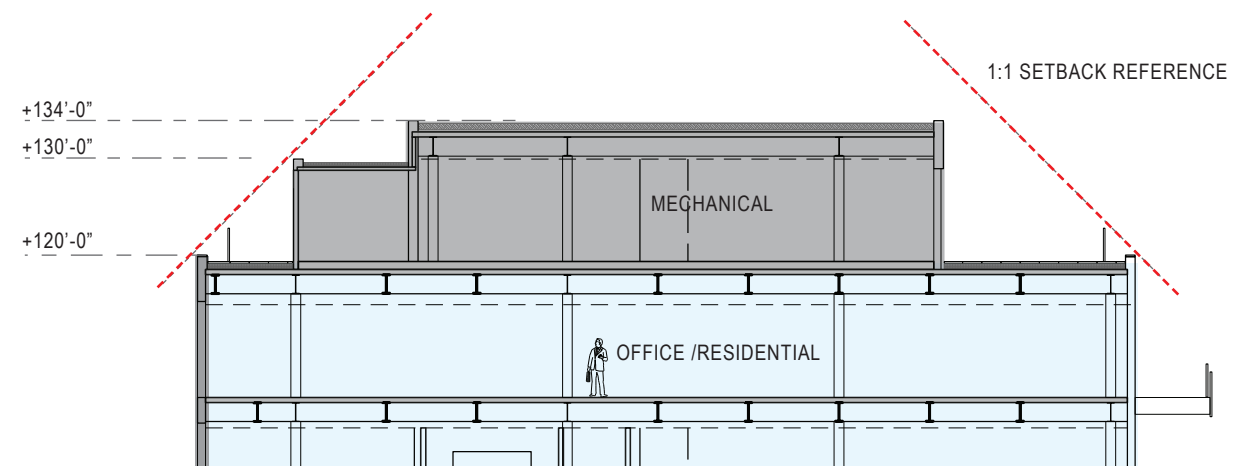

PARTIAL SECTION C-C

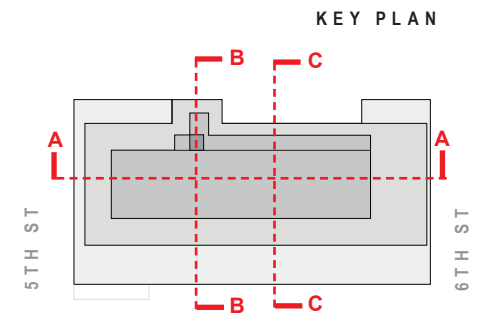

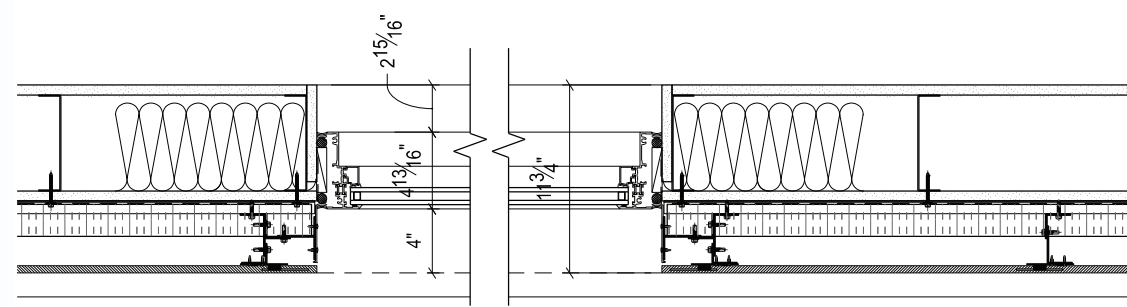
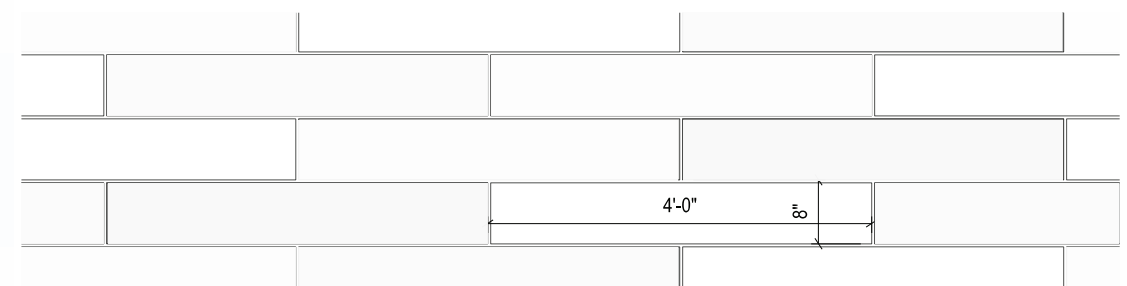
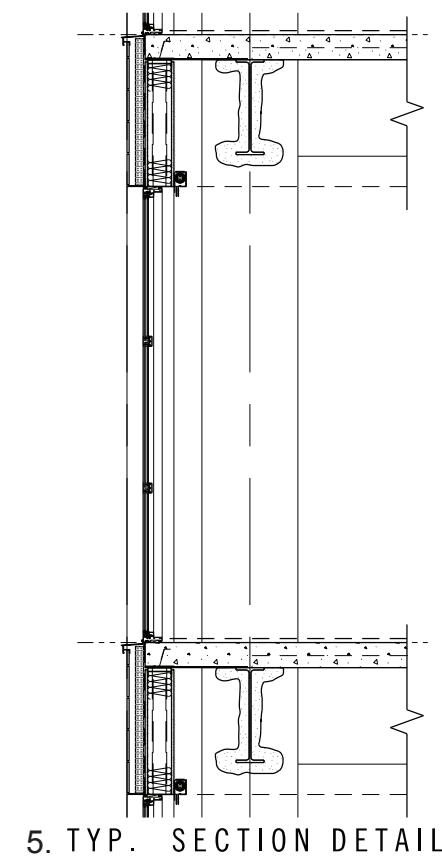
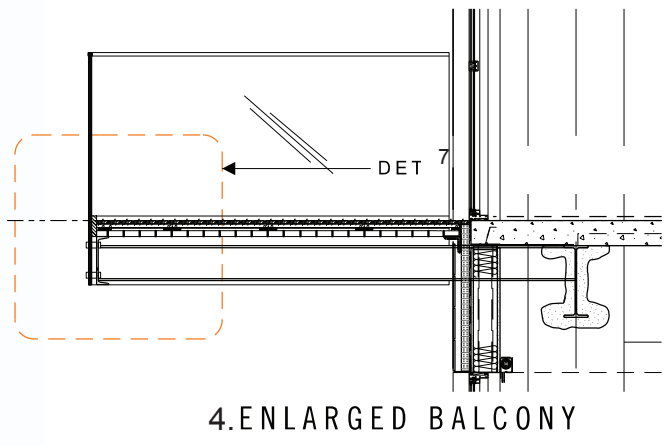
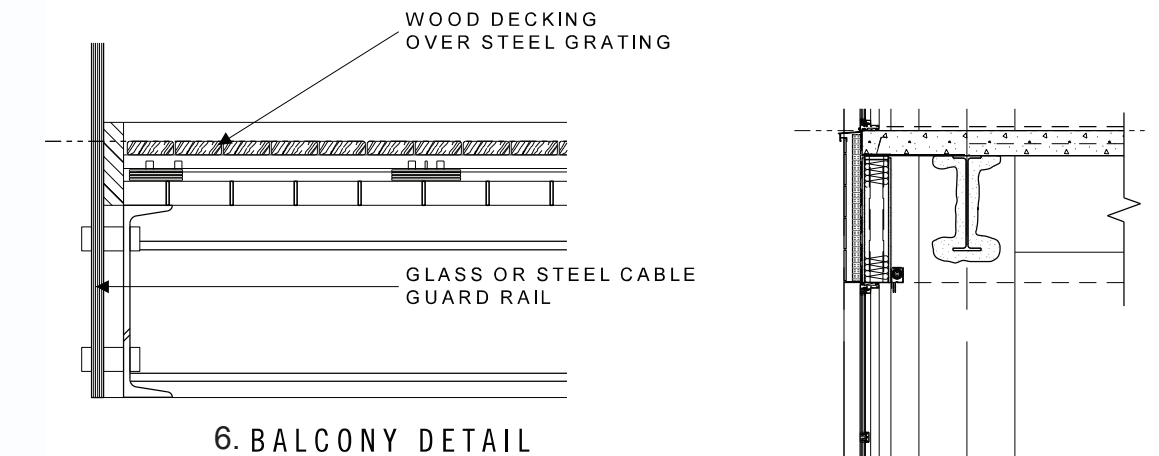

DETAILS AND IMAGES ARE FOR ILLUSTRATIVE PURPOSE ONLY AND SUBJECT TO CHANGE IN FINAL DESIGN.

