

LESTOCK RESIDENCE

1130 4TH STREET N.E.,
WASHINGTON, DC 20002

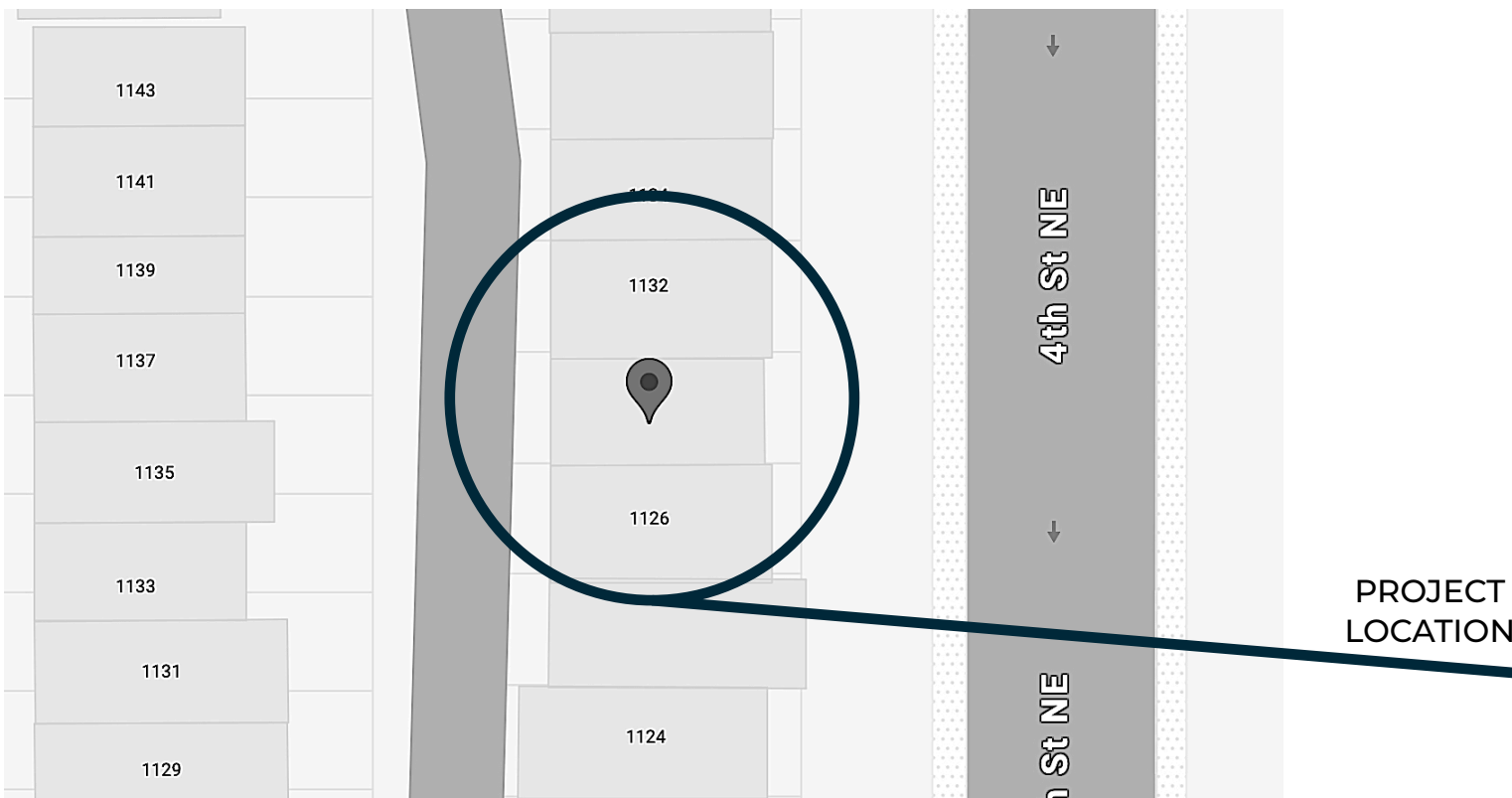

SHEET INDEX:

C0.01		COVER SHEET
A0.01		DECK DRAWING
A0.02		DECK FRAMING
A0.03		ELEVATIONS
A0.04		DETAILS

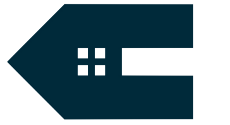

CAPITOL
IMPROVEMENTS LLC

12606 Hillmeade
Station Drive,
Bowie, MD 20720

Tel: 301.769.6909

PROJECT
DECKING

CLIENT
JAKE LESTOCK
1130 4th St. N.E.,
Washington,
DC 200002

DRAWN BY
FLORENCIA JEWELL

SCALE

ISSUE
03.17.25

RE-ISSUE
MM.DD.YY

DESCRIPTION
COVER SHEET

C0.01
Board of Zoning Adjustment
District of Columbia
CASE NO. 211366
EXHIBIT NO. 55



CAPITOL
IMPROVEMENTS LLC

12606 Hillmeade
Station Drive,
Bowie, MD 20720

Tel: 301.769.6909

PROJECT
DECKING

CLIENT
JAKE LESTOCK
1130 4th St. N.E.,
Washington,
DC 20002

DRAWN BY
FLORENCIA JEWELL

SCALE
1/4" = 1'

ISSUE
03.17.25

RE-ISSUE
MM.DD.YY

DESCRIPTION
DECK DRAWING

A0.01

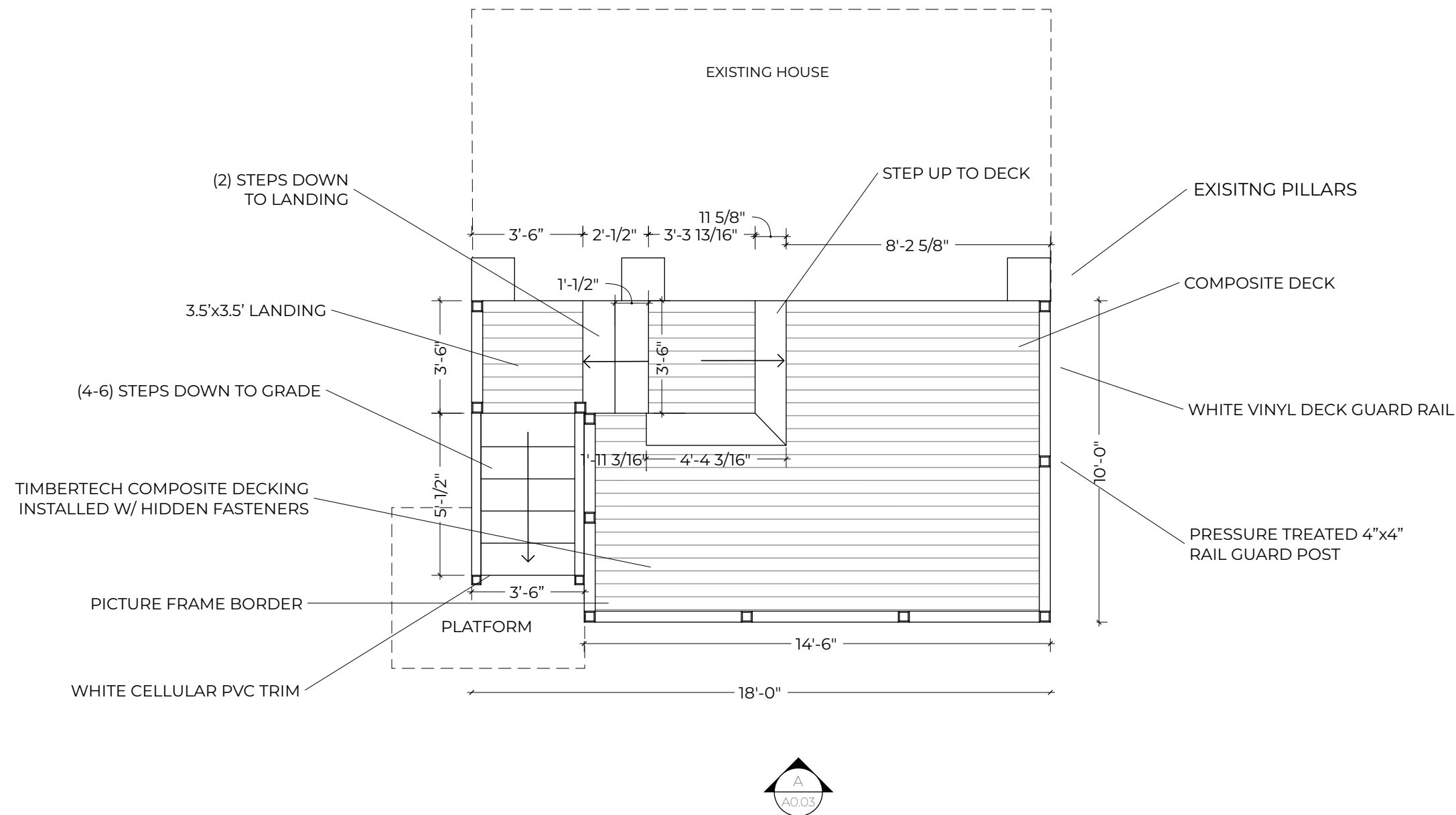



CAPITOL
IMPROVEMENTS LLC

12606 Hillmeade
Station Drive,
Bowie, MD 20720

Tel: 301.769.6909

PROJECT
DECKING

CLIENT
JAKE LESTOCK
1130 4th St. N.E.,
Washington,
DC 20002

DRAWN BY
FLORENCIA JEWELL

SCALE
1/4" = 1'

ISSUE
03.17.25

RE-ISSUE
MM.DD.YY

DESCRIPTION
DECK FRAMING

A0.02

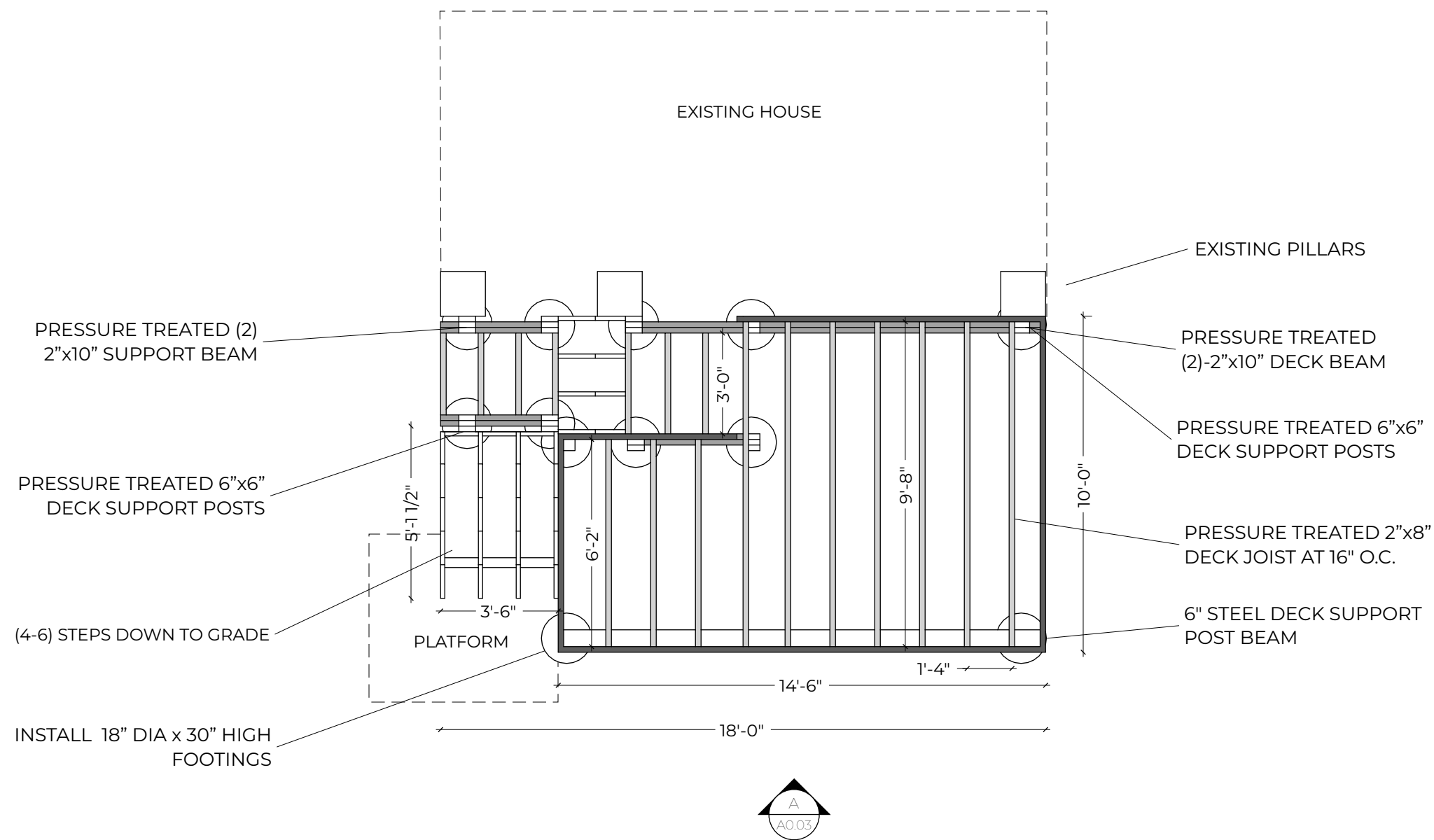



CAPITOL
IMPROVEMENTS LLC

12606 Hillmeade
Station Drive,
Bowie, MD 20720

Tel: 301.769.6909

PROJECT
DECKING

CLIENT
JAKE LESTOCK
1130 4th St. N.E.,
Washington,
DC 20002

DRAWN BY
FLORENCIA JEWELL

SCALE
1/4" = 1'

ISSUE
03.17.25

RE-ISSUE
MM.DD.YY

DESCRIPTION
ELEVATIONS

A0.03

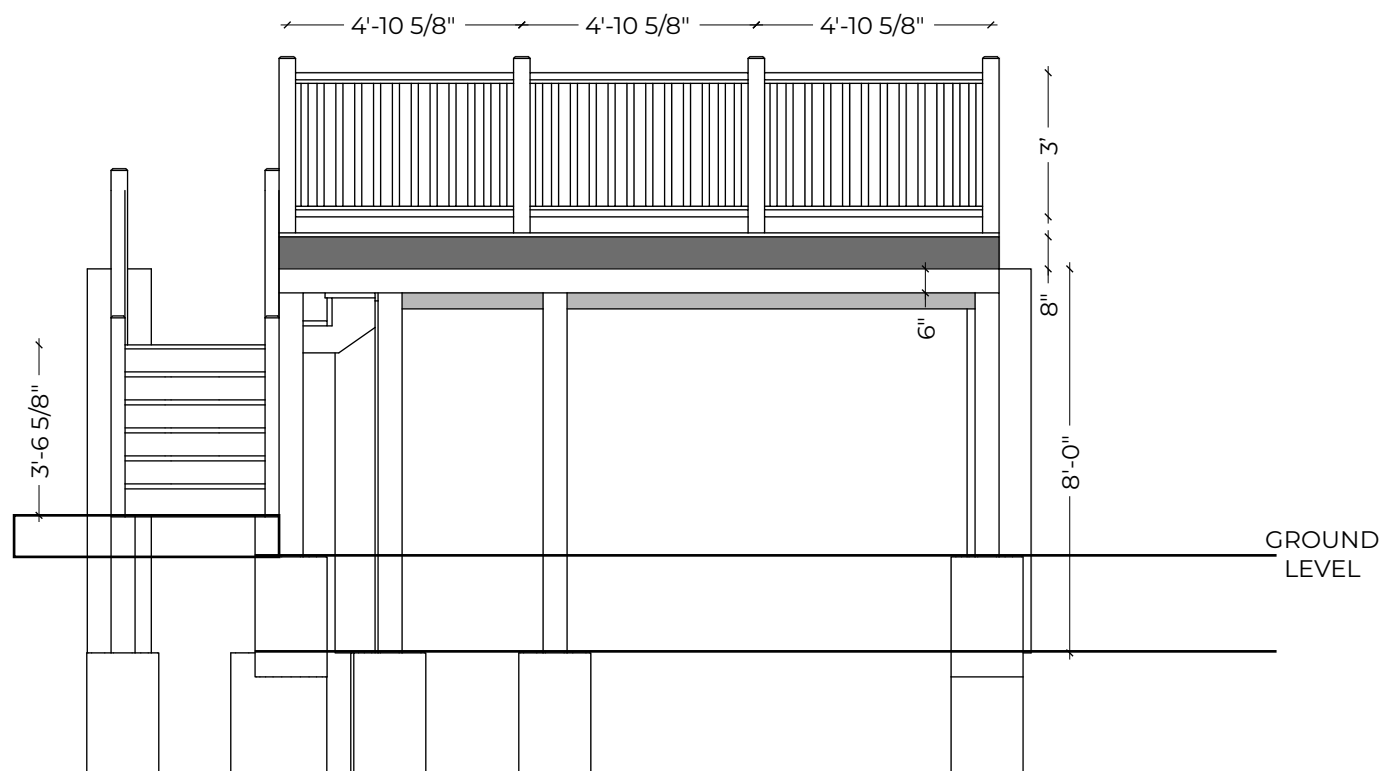

ELEVATION A

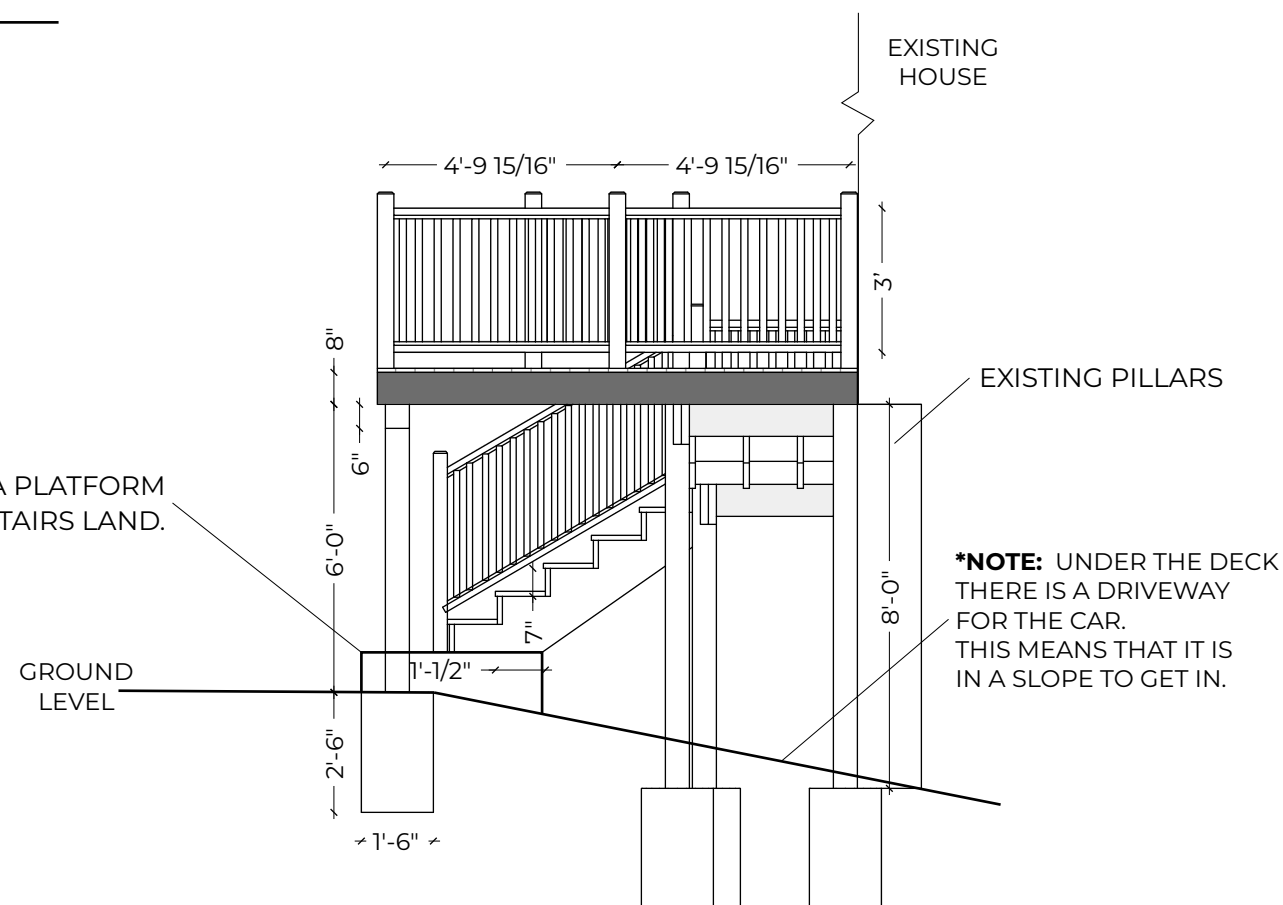

ELEVATION B

***NOTE:** THERE IS A PLATFORM
WHERE THE STAIRS LAND.

***NOTE:** UNDER THE DECK
THERE IS A DRIVEWAY
FOR THE CAR.
THIS MEANS THAT IT IS
IN A SLOPE TO GET IN.

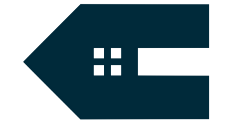

CAPITOL
IMPROVEMENTS LLC

12606 Hillmeade
Station Drive,
Bowie, MD 20720

Tel: 301.769.6909

PROJECT
DECKING

CLIENT
JAKE LESTOCK
1130 4th St. N.E.,
Washington,
DC 20002

DRAWN BY
FLORENCIA JEWELL

SCALE
NOT SCALED

ISSUE
03.17.25

RE-ISSUE
MM.DD.YY

DESCRIPTION
DETAILS

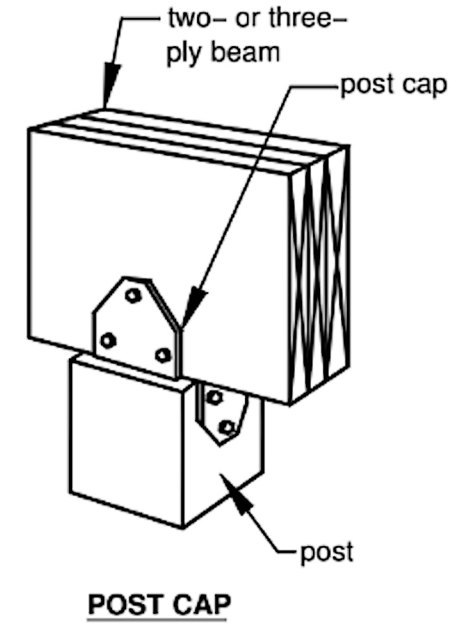
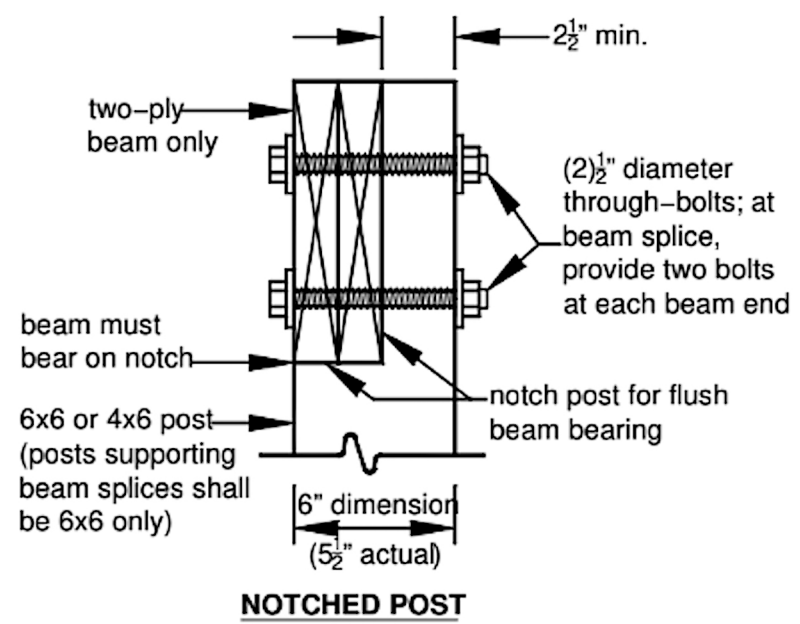

POST-BEAM CONNECTION

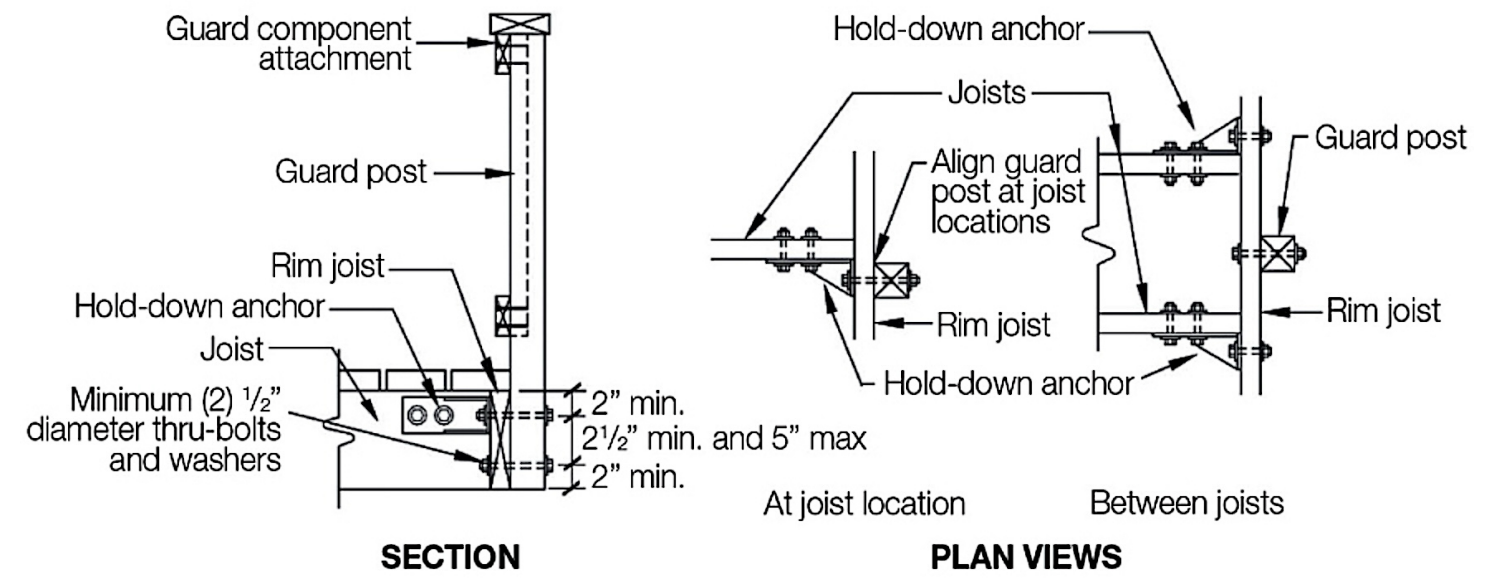

GUARD POST TO RIM JOIST