

**Retaining Walls for 4436 Alabama Ave SE**

**Washington, DC 20019**

**Project Scope:**

The project consists of the construction of a 6' segmented retaining wall in the rear yard .5- ft from the alley and a 3.5 segmented retaining wall 28-ft from the alley to create a flat level space. Additionally the project includes replacement of an existing wooded fence that has collapsed to be place on top of the 6- ft retaining wall and extend round the perimeter of the rear yard. Removal of existing steps down to the alley and replacement with bolder steppers to the southside of the yard.

## **Table of Contents**

Civil 1 – Existing Conditions

Civil 2 – Proposed Conditions

Details 1 - Block Details

Details 2 - Typical Section 6ft Wall

Details 3 - Typical Section 3.5ft Wall

Details 4 - Typical Section Near Alley

Details 5 - Cross Section - Design Table

Details 6 - Typical Front Elevation

Details 7 - Base Preparation Detail

Details 8 - Typical Step-up Base Detail

Details 9 - Reinforcement Connection Detail

Details 10 - Reinforcement Outside Corners

Details 11 - Capping Detail

Details 12 - Drainage Pipe Through Toe Sloe

Details 13 - Drainage Pipe Through Wall

Details 14 - Typical Fence Post Cross-section

Details 15 - Landings-Step-Cross Section Typical

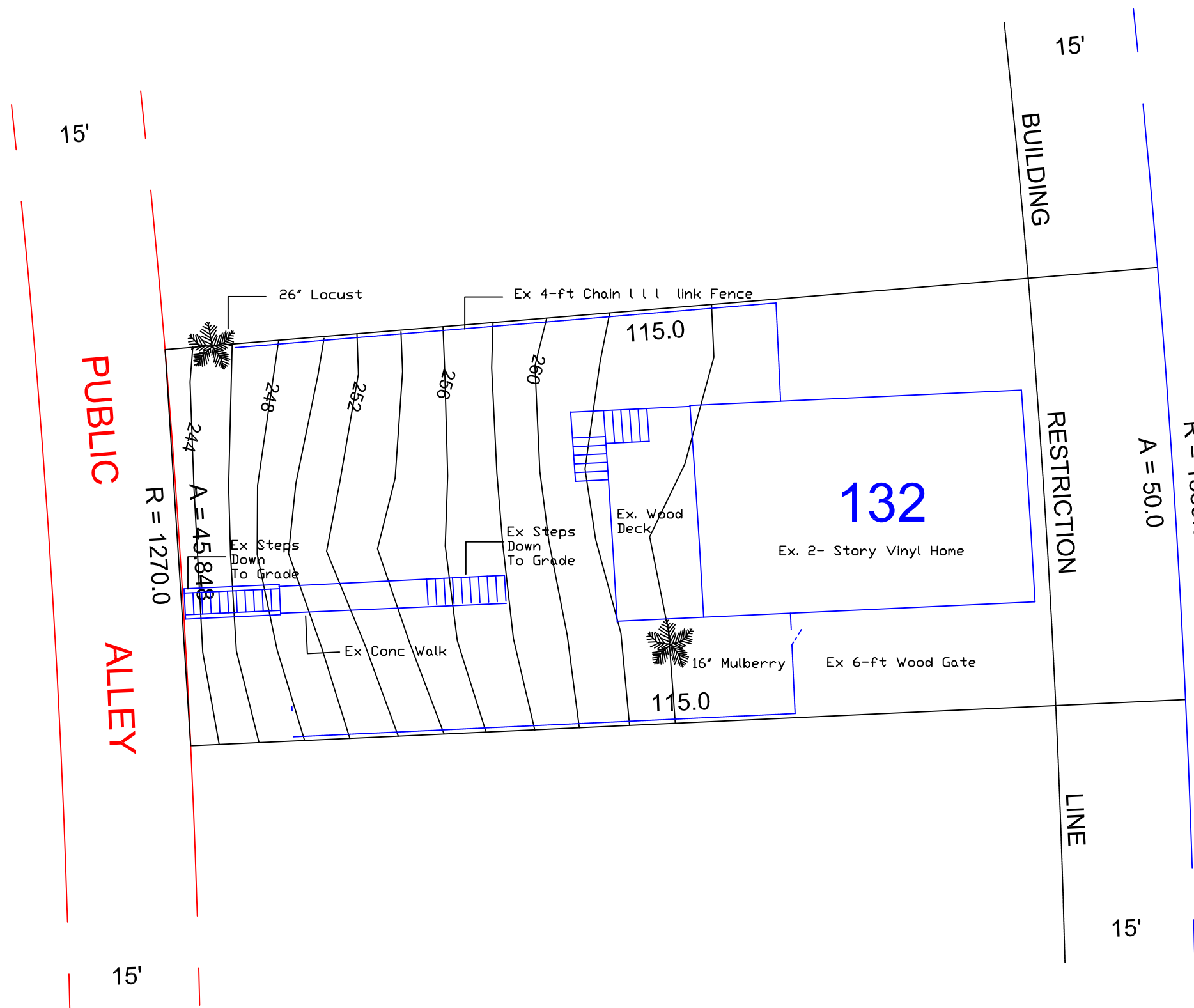

ALABAMA AVENUE, S.E.



PUBLIC

ALLEY

15'

15'

BUILDING

RESTRICTION

LINE

15'

15'

R = 1385.0

A = 50.0

R = 1270.0

A = 45,848

### Existing Conditions

4436 Alabama Ave SE  
Washington, DC 20019

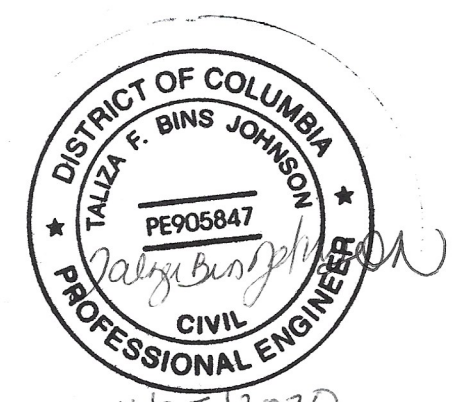

11/23/2020

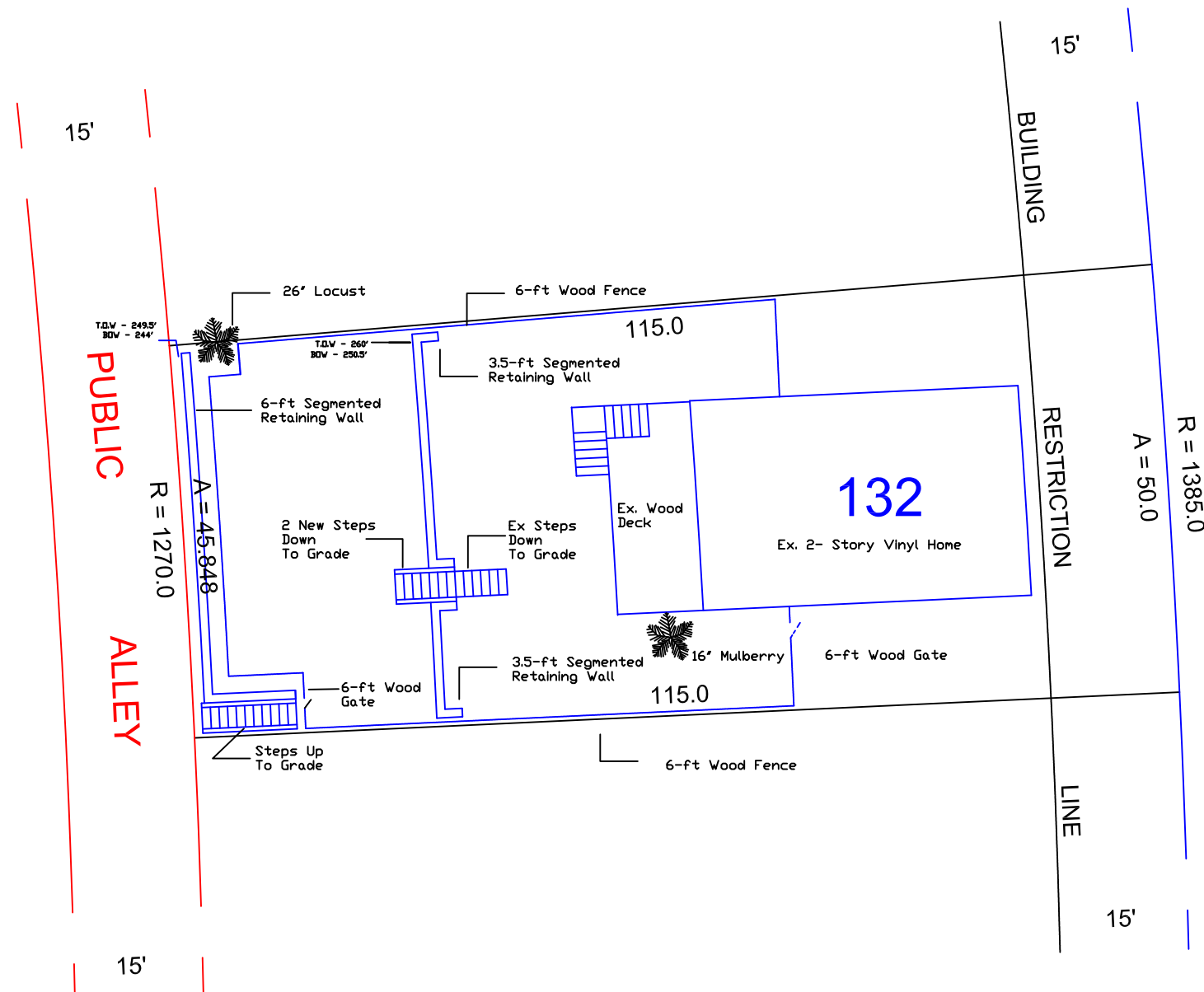

ALABAMA AVENUE, S.E.



Proposed Conditions  
 4436 Alabama Ave SE  
 Washington DC 20019

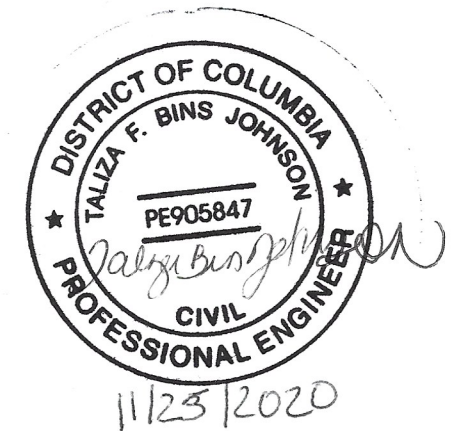

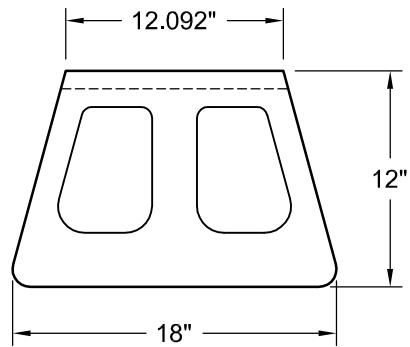

TOP VIEW

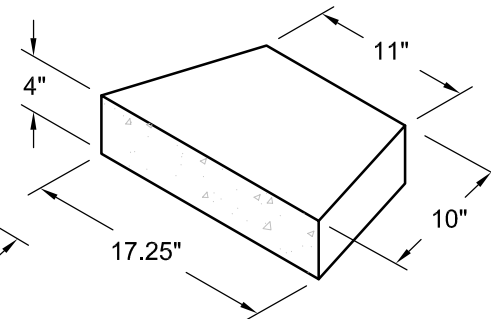
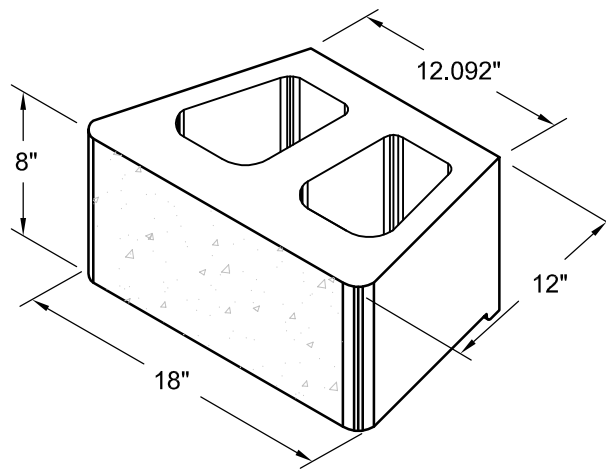

CAP UNIT

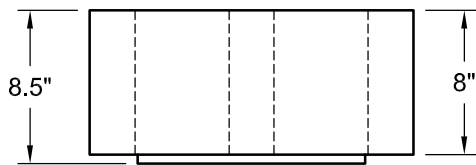

FRONT VIEW

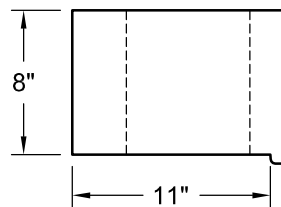

SIDE VIEW

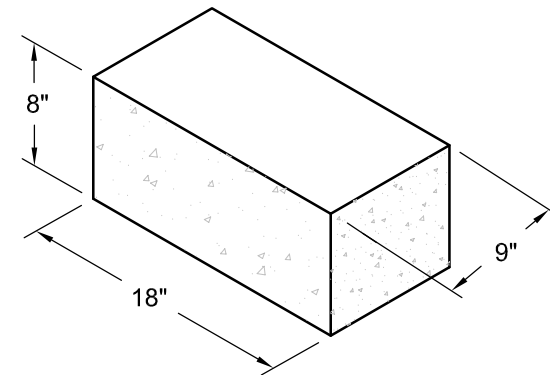

CORNER UNIT

4436 Alabama Ave SE  
Washington, DC 20019



© 2015 Anchor Wall Engineering, LLC  
© and ™ Anchor Wall Systems, Inc.  
[www.anchorwall.com](http://www.anchorwall.com)

This drawing is for illustrative purposes only and should not be used for construction without the signature of a registered professional engineer.

Diamond Pro Stone Cut® Retaining Wall System

Individual Block Details

Scale: 3/8" = 1'-0"	Drawn by: SB
Date: 1/19/2016	Drawing number: DPCR01

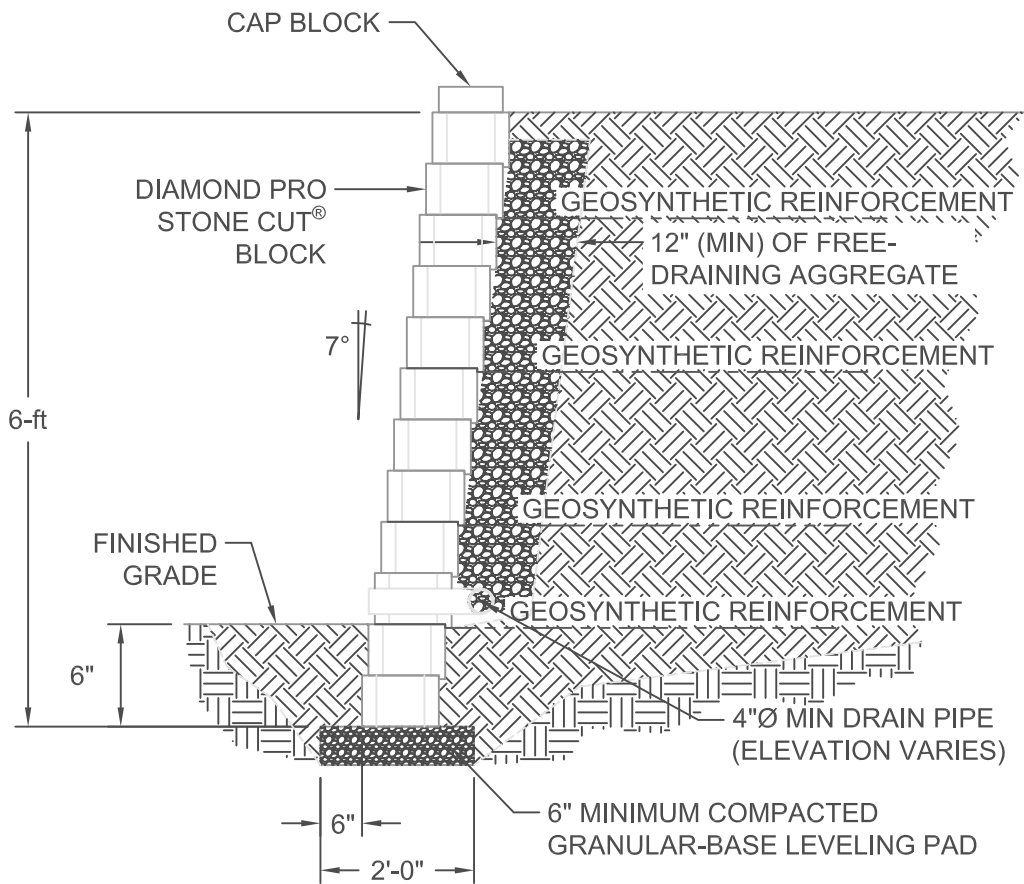

4436 Alabama Ave SE  
Washington, DC 20019

TYPICAL 6-FT REINFORCED WALL-SECTION

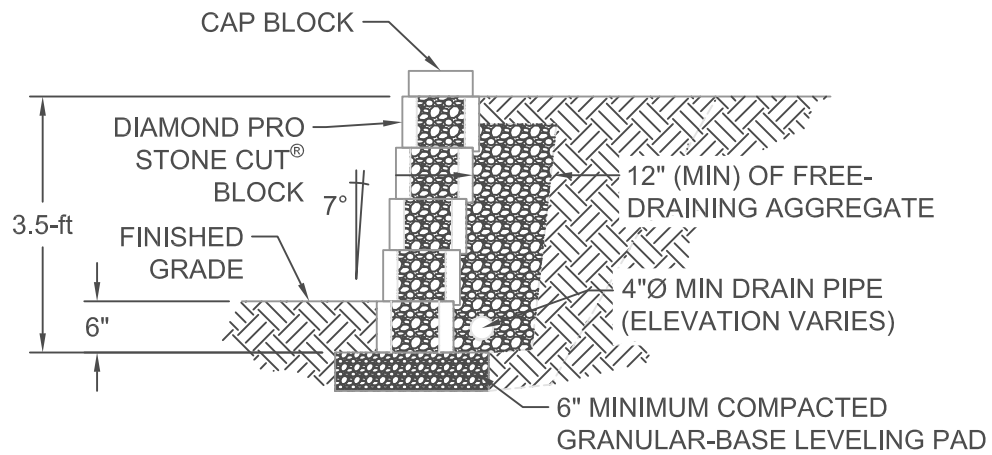

**TYPICAL 3.5-FT WALL-SECTION**

**4436 Alabama Ave SE  
Washington, DC 20019**

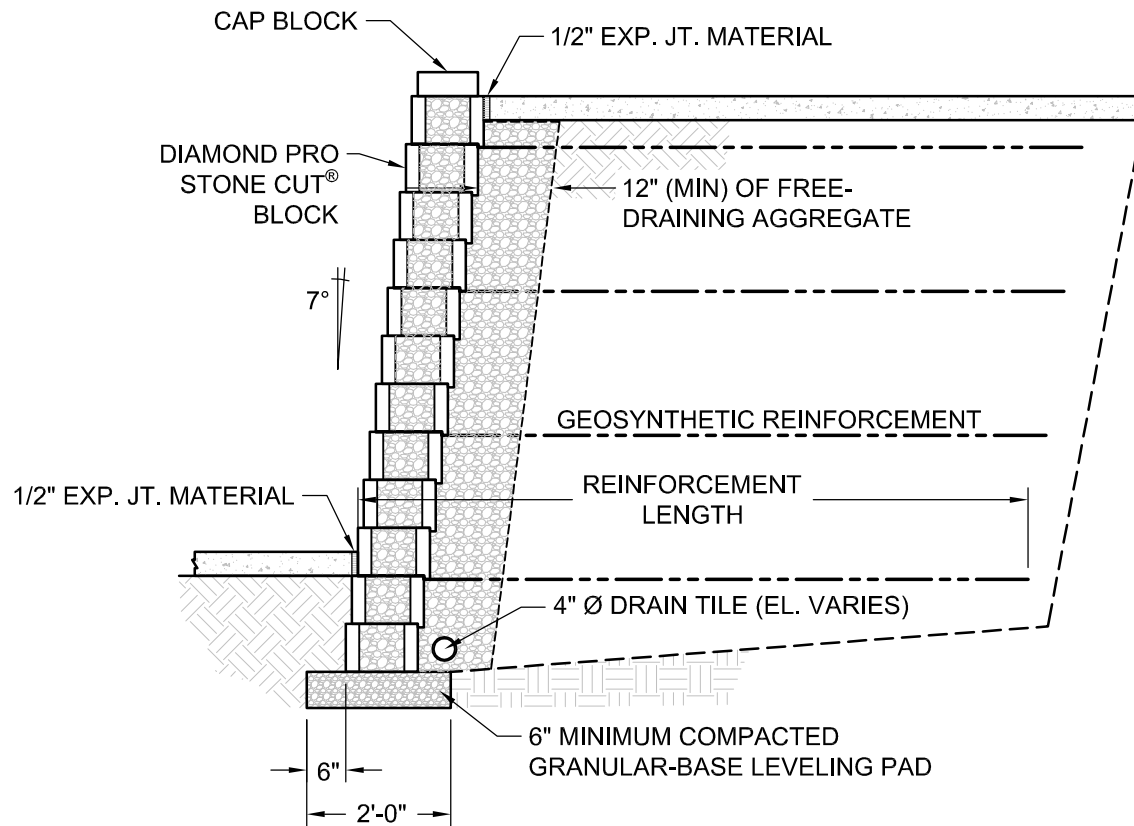

4436 Alabama Ave SE  
 Washington, DC 20019



© 2015 Anchor Wall Engineering, LLC  
 © and ™ Anchor Wall Systems, Inc.  
[www.anchorwall.com](http://www.anchorwall.com)

This drawing is for illustrative purposes only and should not be used for construction without the signature of a registered professional engineer.

## Diamond Pro Stone Cut® Retaining Wall System

### Typical Cross Section with Sidewalk

Scale:  
 3/8" = 1'-0"

Drawn by:  
 SB

Date:  
 1/19/2016

Drawing number:  
 DPCR14



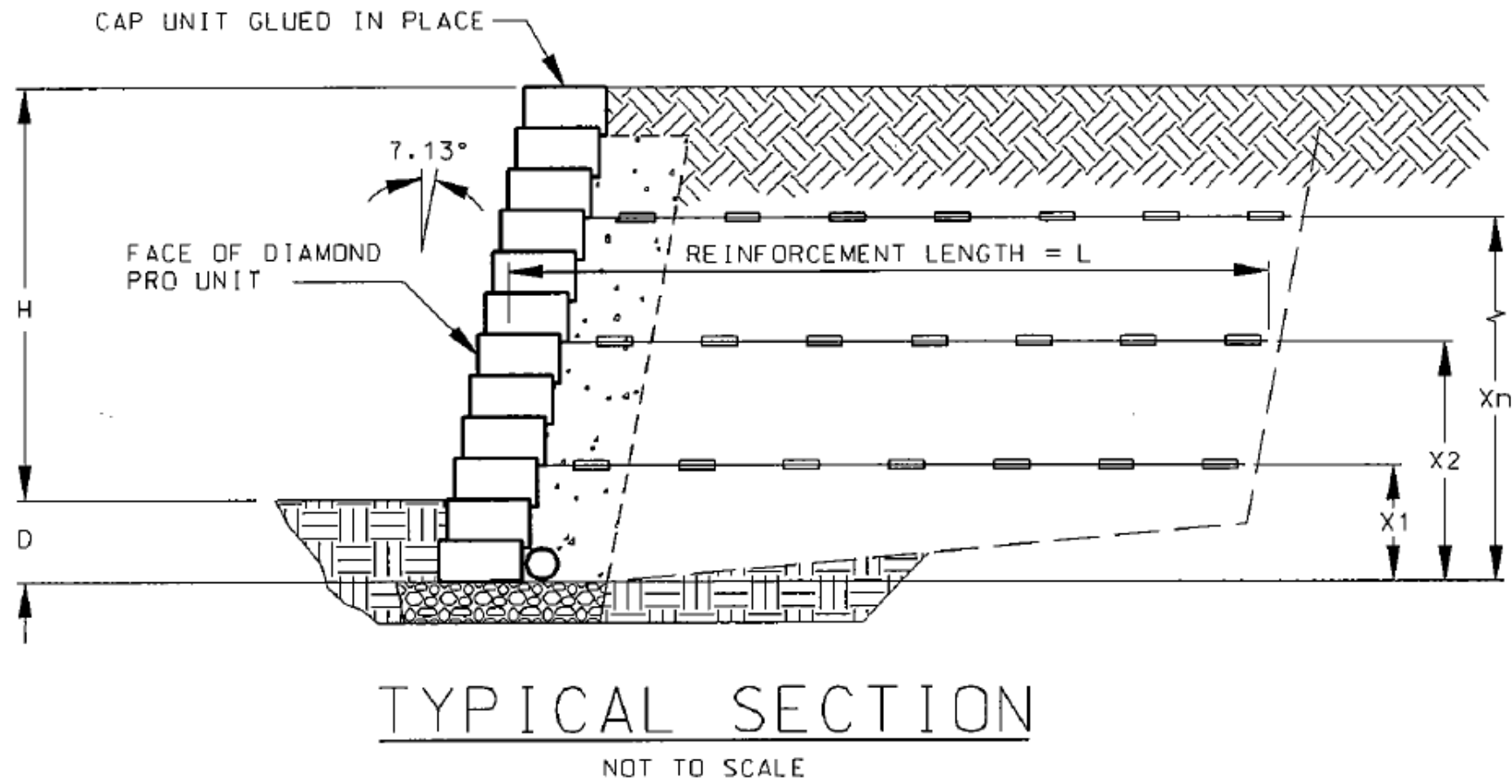

**DESIGN TABLE - REINFORCEMENT**

EXPOSE WALL HEIGHT H (ft)	DEPTH BELOW GRADE D (in)	TOTAL NO. OF COURSES FOR FINISHED	LENGTH L (ft)	GEOSYNTHETIC PLACEMENT DISTANCE UP FROM WALL BASE (FT)			
				X <sub>1</sub>	X <sub>2</sub>	X <sub>3</sub>	X <sub>n</sub>
5.5'	6"	9	6'	2'	4'		

Reinforcement : Diamond Pro Diamond Pro  
Mirafi 3xt, Raugrid, Huesker

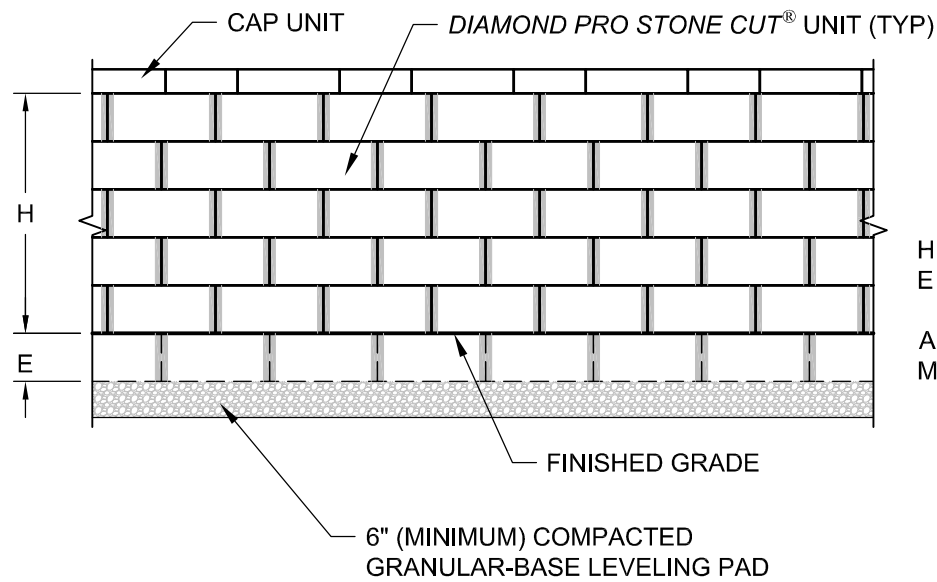

H = EXPOSED WALL HEIGHT (VARIES)  
 E = EMBEDMENT DEPTH (6" MINIMUM)

ADJUST BLOCKS AS NEEDED TO  
 MAINTAIN RUNNING BOND

4436 Alabama Ave SE  
 Washington, DC 20019



© 2015 Anchor Wall Engineering, LLC  
 © and ™ Anchor Wall Systems, Inc.  
[www.anchorwall.com](http://www.anchorwall.com)

This drawing is for illustrative purposes only and should not be used for construction without the signature of a registered professional engineer.

### Diamond Pro Stone Cut® Retaining Wall System

### Typical Elevation View

Scale: 3/8" = 1'-0"	Drawn by: SB
Date: 1/19/2016	Drawing number: DPCR34

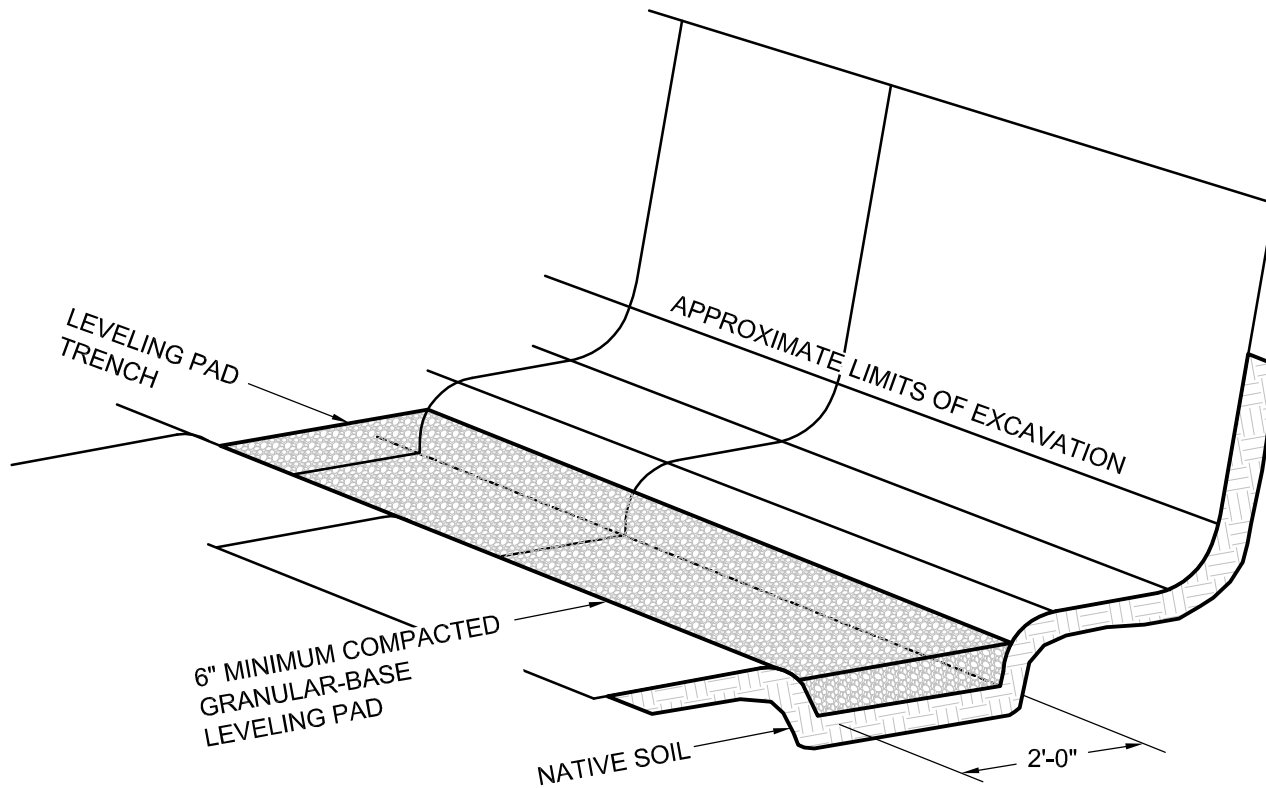

4436 Alabama Ave SE  
 Washington, DC 20019



© 2015 Anchor Wall Engineering, LLC  
 © and ™ Anchor Wall Systems, Inc.  
[www.anchorwall.com](http://www.anchorwall.com)

This drawing is for illustrative purposes only and should not be used for construction without the signature of a registered professional engineer.

### Diamond Pro Stone Cut® Retaining Wall System

### Base Preparation Detail

Scale: None	Drawn by: SB
Date: 1/19/2016	Drawing number: DPCR04

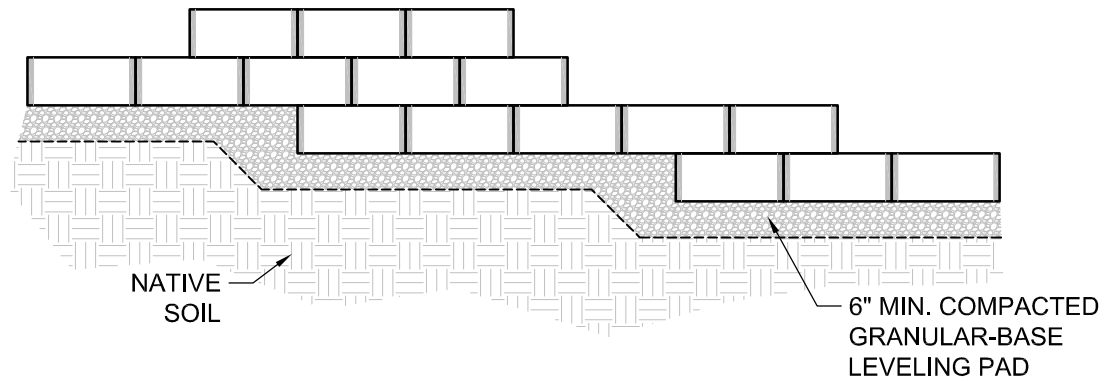

4436 Alabama Ave SE  
Washington, DC 20019



© 2015 Anchor Wall Engineering, LLC  
© and ™ Anchor Wall Systems, Inc.  
[www.anchorwall.com](http://www.anchorwall.com)

This drawing is for illustrative purposes only and should not be used for construction without the signature of a registered professional engineer.

Diamond Pro Stone Cut® Retaining Wall System

Typical Base Step-Up Detail

Scale:  
3/8" = 1'-0"

Drawn by:  
SB

Date:  
1/19/2016

Drawing number:  
DPCR05

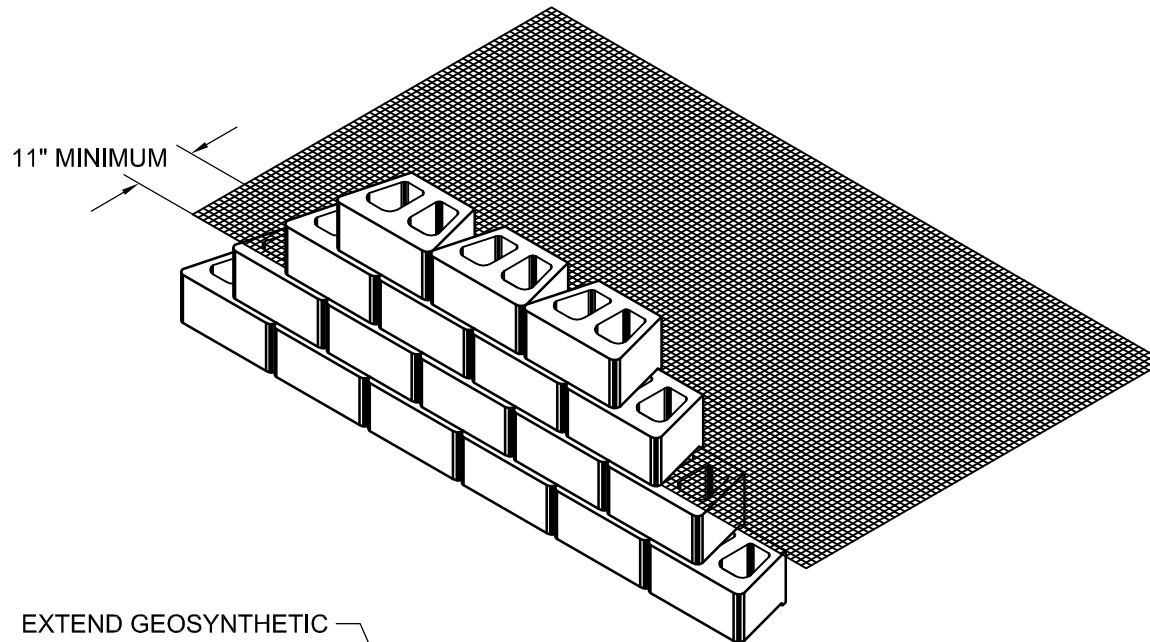

EXTEND GEOSYNTHETIC REINFORCEMENT TO WITHIN 1" OF THE LOWER BLOCK FACE

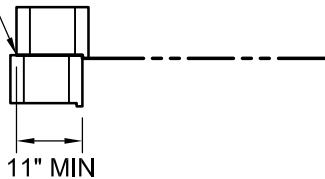

4436 Alabama Ave SE  
Washington, DC 20019



© 2015 Anchor Wall Engineering, LLC  
© and ™ Anchor Wall Systems, Inc.  
[www.anchorwall.com](http://www.anchorwall.com)

This drawing is for illustrative purposes only and should not be used for construction without the signature of a registered professional engineer.

## Diamond Pro Stone Cut® Retaining Wall System

### Reinforcement Connection Detail

Scale:	None	Drawn by:	SB
Date:	1/19/2016	Drawing number:	DPCR03

**NOTE:**  
 IN THE "CROSS-OVER AREA" OF REINFORCEMENT, ONE OF THE LAYERS OF REINFORCEMENT SHOULD BE LOWERED OR RAISED ONE COURSE TO ALLOW PLACEMENT OF THE REINFORCEMENT WITH THE PRINCIPLE REINFORCEMENT STRENGTH DIRECTION PROPERLY ORIENTATED. THE REINFORCEMENT SHOULD NOT EXTEND INTO THE SEGMENTAL RETAINING WALL UNITS ON THE RETURN LEG OF THE 90-DEGREE CORNER.

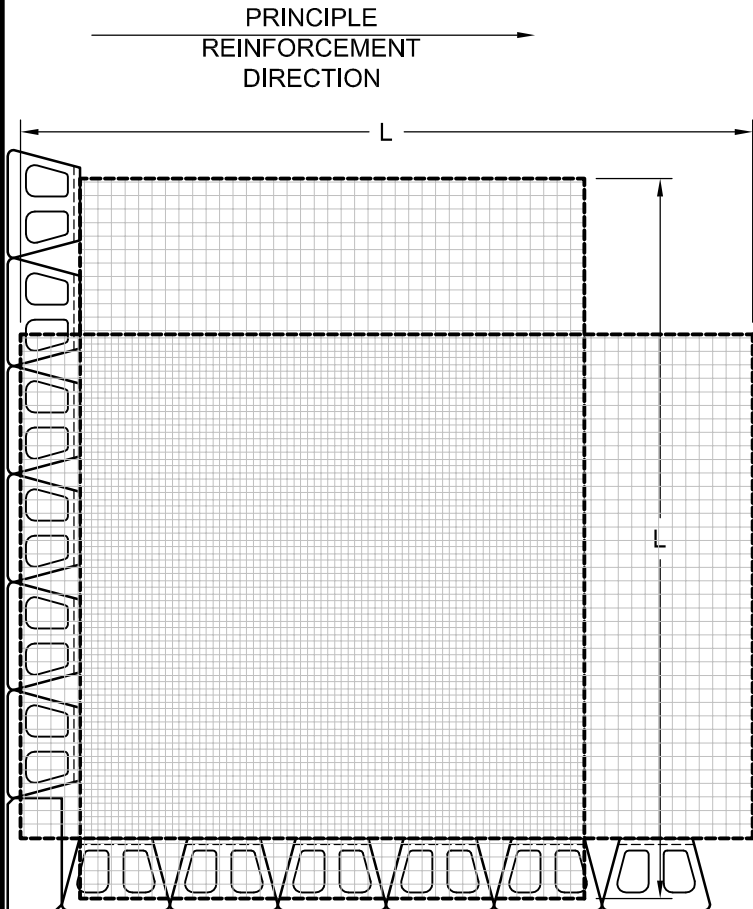

**NOTE: USE ADHESIVE ON EXPOSED PARTIAL UNITS CUT UNITS (X) TO MAINTAIN RUNNING BOND**

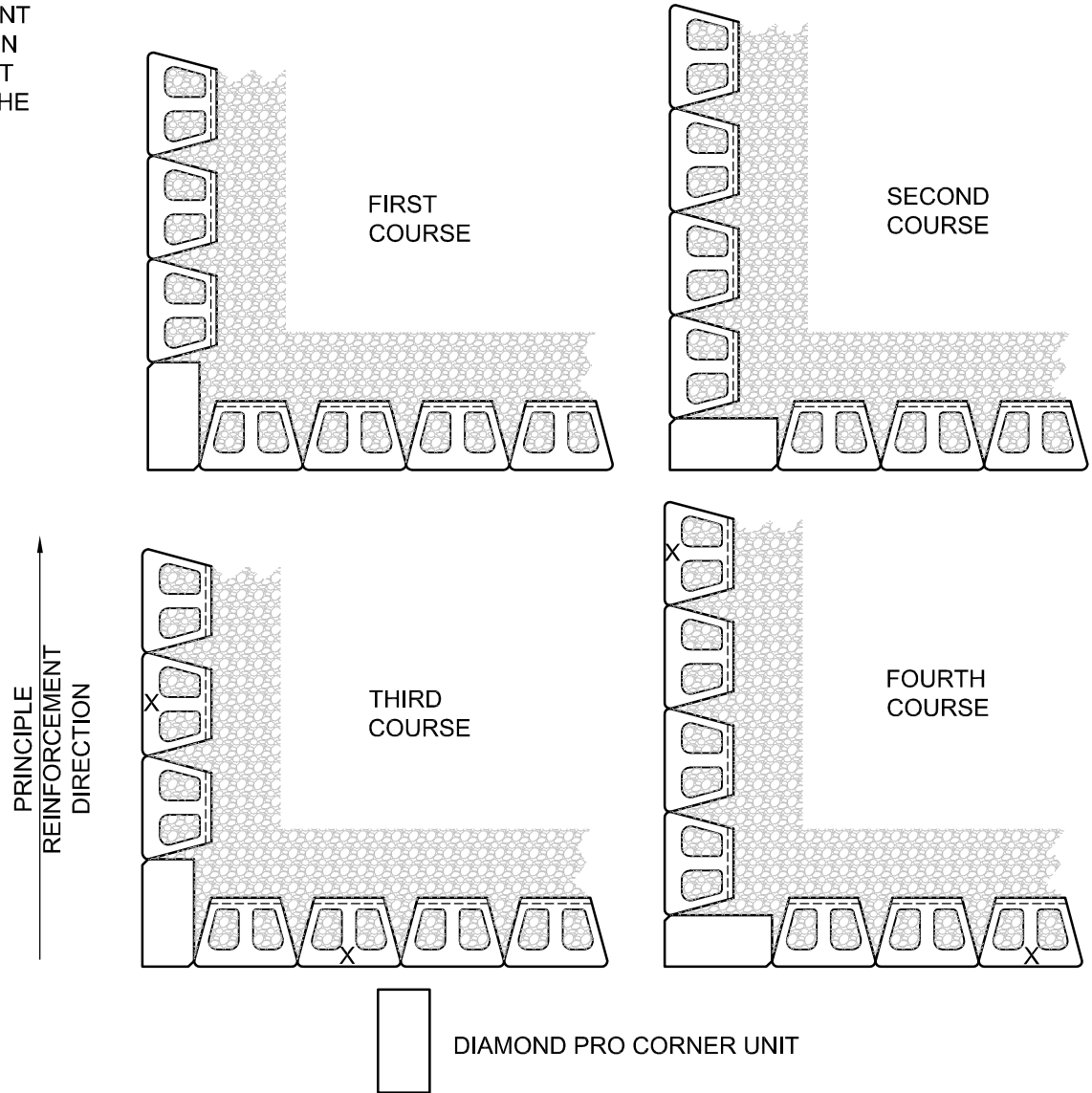

4436 Alabama Ave SE Washington, DC 20019



© 2015 Anchor Wall Engineering, LLC  
 © and ™ Anchor Wall Systems, Inc.  
[www.anchorwall.com](http://www.anchorwall.com)

This drawing is for illustrative purposes only and should not be used for construction without the signature of a registered professional engineer.

## Diamond Pro Stone Cut® Retaining Wall System

### Outside Corners

Scale:  
 3/8" = 1'-0"

Drawn by:  
 SB

Date:  
 1/19/2016

Drawing number:  
 DPCR29

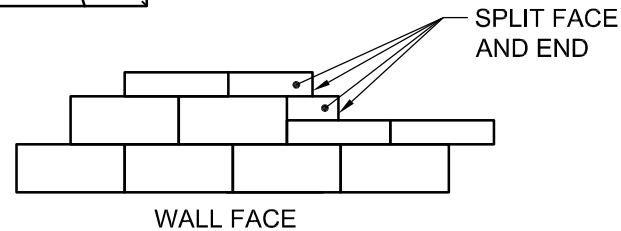
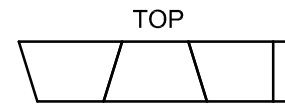
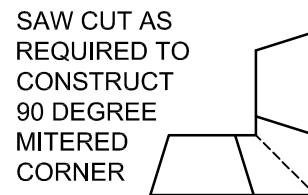
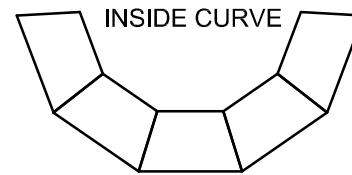
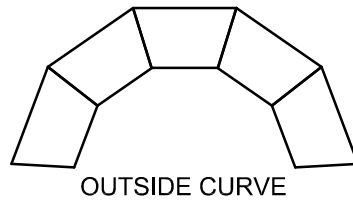

1. ALWAYS START CAPPING WALL FROM THE LOWEST ELEVATION.
2. LAYOUT CAPS PRIOR TO USING ADHESIVE.
3. CUT CAPS TO FIT. VARIOUS COMBINATIONS OF LONG AND SHORT CAP FACES WILL BE NECESSARY FOR RADII GREATER THAN THE MINIMUM.
4. ALTERNATE SHORT AND LONG CAP FACES EVERY OTHER CAP TO ACHIEVE A STRAIGHT ROW OF CAPS.
5. USE EXTERIOR-GRADE CONSTRUCTION ADHESIVE TO SECURE CAPS.

4436 Alabama Ave SE  
Washington, DC 20019



© 2015 Anchor Wall Engineering, LLC  
© and ™ Anchor Wall Systems, Inc.  
[www.anchorwall.com](http://www.anchorwall.com)

This drawing is for illustrative purposes only and should not be used for construction without the signature of a registered professional engineer.

Diamond Pro Stone Cut® Retaining Wall System

Capping Detail

Scale: 3/8" = 1'-0"	Drawn by: SB
Date: 1/19/2016	Drawing number: DPCR02

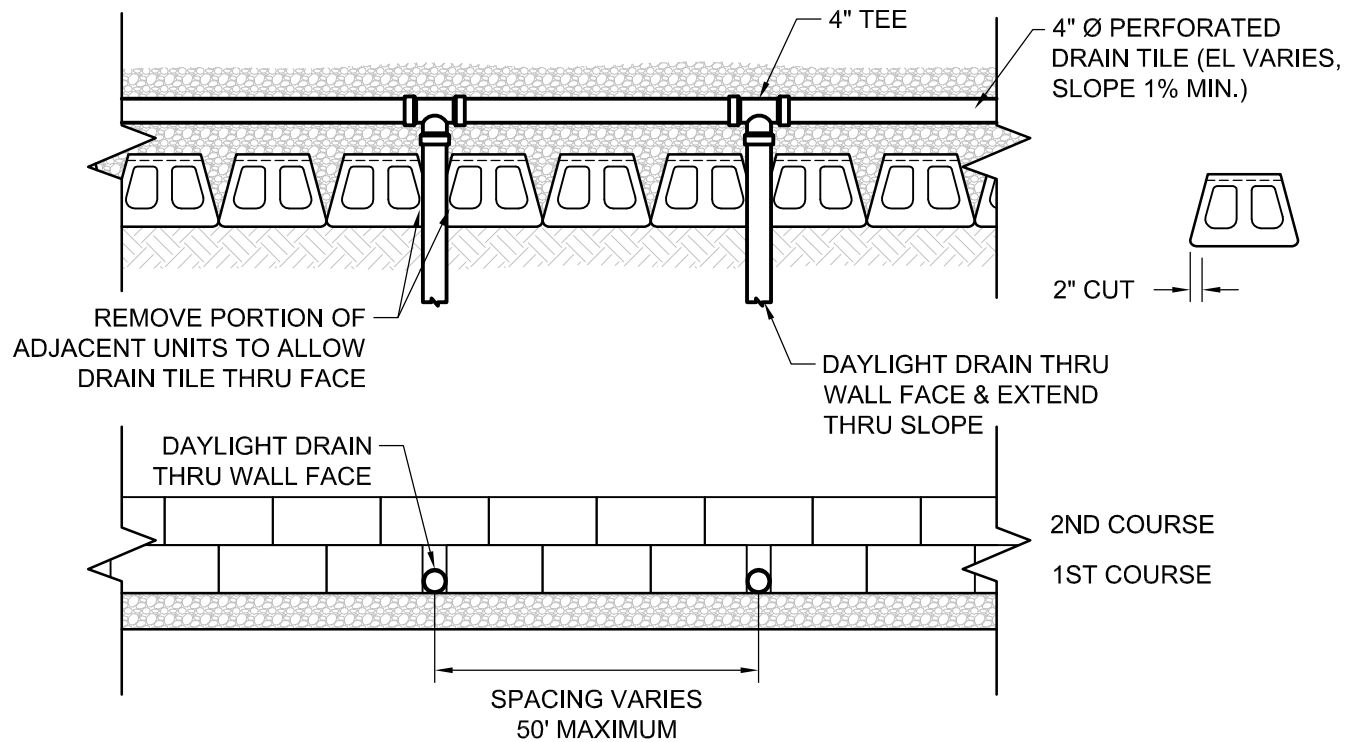

4436 Alabama Ave SE  
Washington, DC 20019



© 2015 Anchor Wall Engineering, LLC  
© and ™ Anchor Wall Systems, Inc.  
www.anchorwall.com

This drawing is for illustrative purposes only and should not be used for construction without the signature of a registered professional engineer.

## Diamond Pro Stone Cut® Retaining Wall System

### Drain Pipe Through Toe Slope

Scale:  
3/8" = 1'-0"

Drawn by:  
SB

Date:  
1/19/2016

Drawing number:  
DPCR20



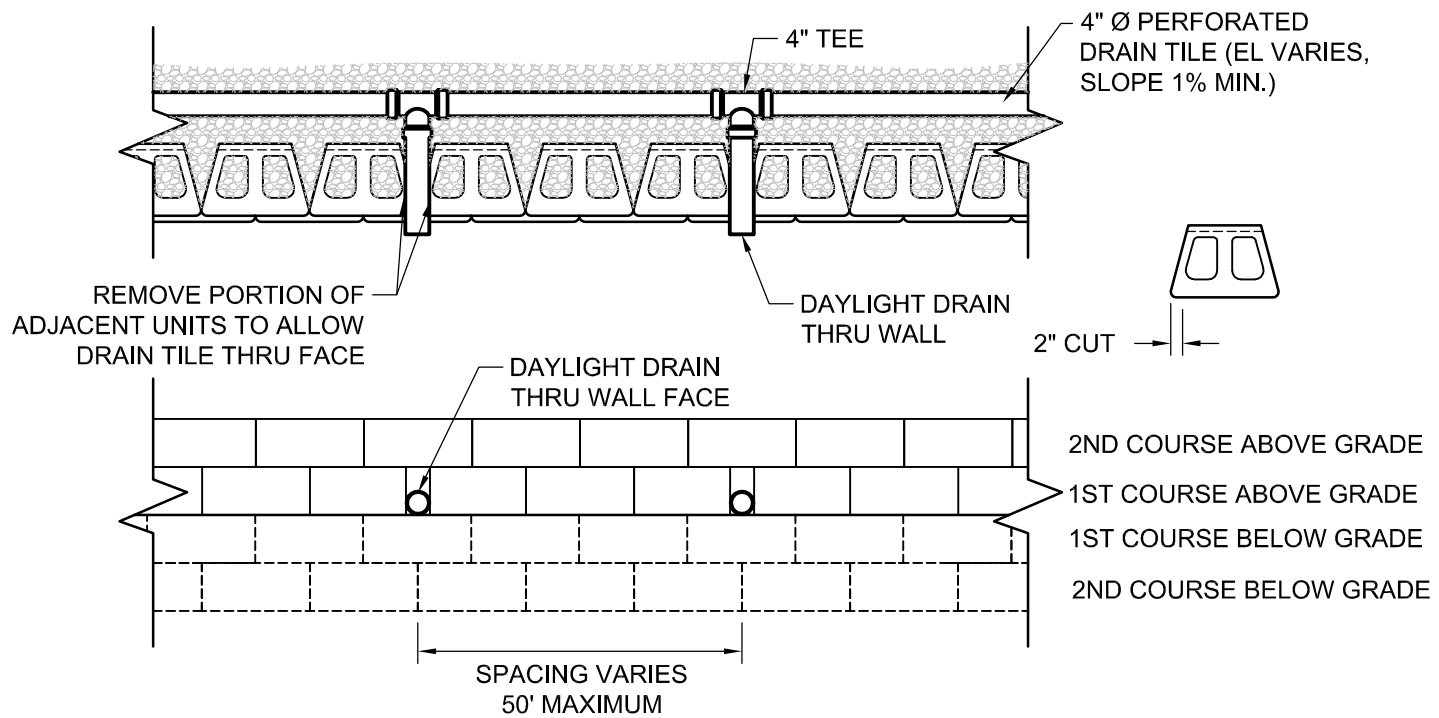

4436 Alabama Ave SE  
 Washington, DC 20019



© 2015 Anchor Wall Engineering, LLC  
 © and ™ Anchor Wall Systems, Inc.  
[www.anchorwall.com](http://www.anchorwall.com)

This drawing is for illustrative purposes only and should not be used for construction without the signature of a registered professional engineer.

### Diamond Pro Stone Cut® Retaining Wall System

### Drain Pipe Through Wall Face

Scale:  
 3/8" = 1'-0"

Drawn by:  
 SB

Date:  
 1/19/2016

Drawing number:  
 DPCR19

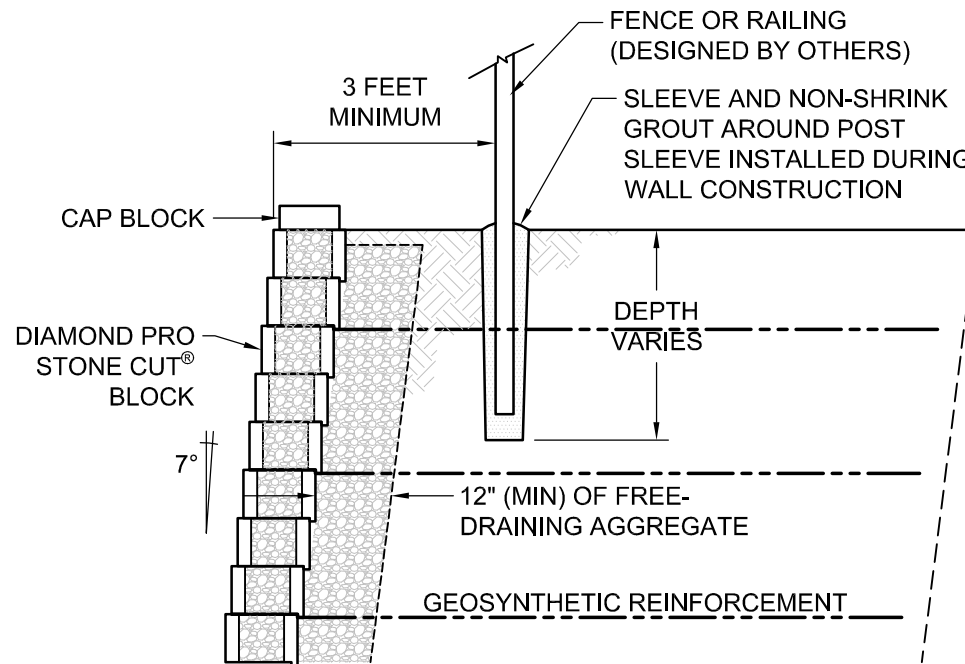

4436 Alabama Ave SE  
Washington, DC 20019



© 2015 Anchor Wall Engineering, LLC  
© and ™ Anchor Wall Systems, Inc.  
[www.anchorwall.com](http://www.anchorwall.com)

This drawing is for illustrative purposes only and should not be used for construction without the signature of a registered professional engineer.

## Diamond Pro Stone Cut® Retaining Wall System

### Typical Fence Cross Section

Scale:  
3/8" = 1'-0"

Drawn by:  
SB

Date:  
1/19/2016

Drawing number:  
DPCR09

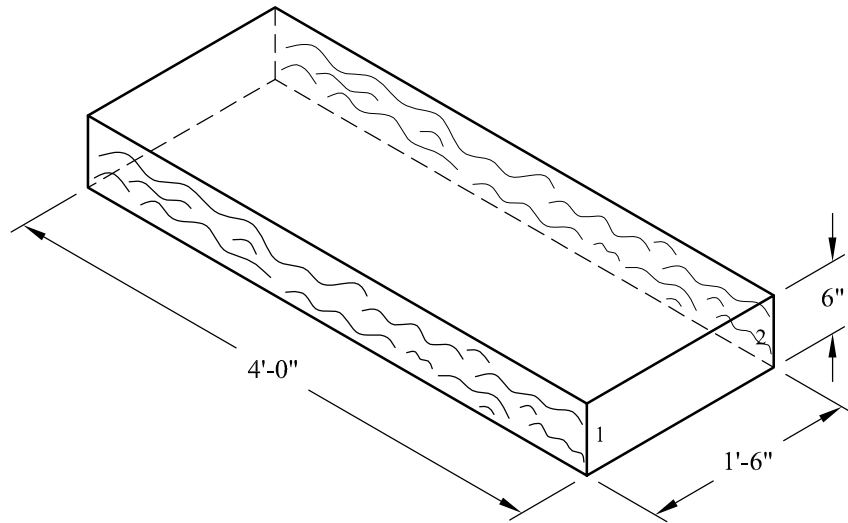

THE TEXTURES ON SIDES 1 AND 2 ARE DESIGNED TO MARRY WITH MINIMAL GAPPING BETWEEN THE UNITS

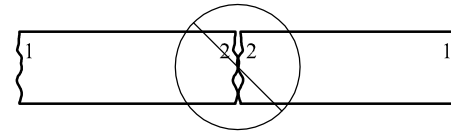
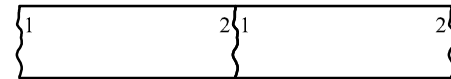

Anchor Wall Systems, Inc.  
5959 Baker Road, Suite 390  
Minnetonka, MN 55345

© 2014 Anchor Wall Systems, Inc.  
® and ™ Anchor Wall Systems, Inc.

Drawn By:	AWE
Date:	1/27/2015
Scale:	1/2"=1'-0"

Drawing Title:

## Landings™ Step Unit Unit Details

Typical Details For  
Segmental Retaining Walls

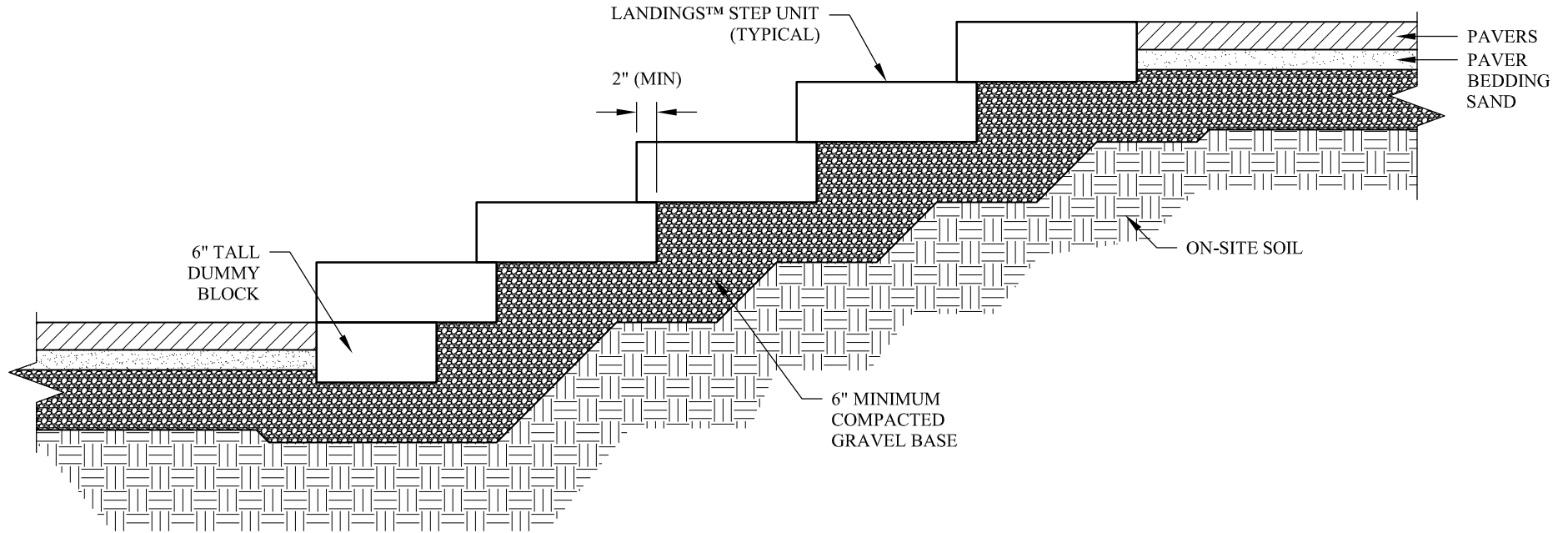

Anchor Wall Systems, Inc.  
5959 Baker Road, Suite 390  
Minnetonka, MN 55345

© 2014 Anchor Wall Systems, Inc.  
® and ™ Anchor Wall Systems, Inc.

Drawn By: AWE  
Date: 1/23/2015  
Scale: 3/4"=1'-0"

Drawing Title:

Landings™ Step Unit  
Typical Cross Section

Typical Details For  
Segmental Retaining Walls