

# C & O CANAL

TOW PATH

Edge of water

Need relief from 711.6.a, subtitle C 20' Entry Drive requirements

PROPERTY LINE

+ 38.00

STORAGE

11.0%

Admin.

Trash

Convenience Lobby

Need relief from 712.5, subtitle C Aisle and Size requirements

16' - 2"  
Drive Aisle

Studio

578 SF

1BR

735 SF

2BR+Den

1421 SF

# WATER STREET BELOW

EXISTING STRUCTURE TO REMAIN

NEW STRUCTURE

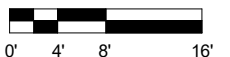

THE EXTERIOR ELEVATIONS, INCLUDING DOOR AND WINDOW SIZES AND LOCATIONS, THE INTERIOR PARTITIONS LOCATIONS, THE NUMBER, SIZE, AND LOCATIONS OF RESIDENTIAL UNITS, STAIRS, AND ELEVATORS, ARE PRELIMINARY AND ARE SHOWN FOR ILLUSTRATIVE PURPOSES ONLY. THE FINAL LAYOUTS MAY VARY.



PROPOSED PLAN- SECOND FLOOR- CANAL

3401 WATER STREET NW

01.15.2020

SCALE: 1'-0"=1/16"

BZA SUBMISSION

1825 K STREET, NW SUITE 300 WASHINGTON D.C. 20006

Board of Zoning Adjustment  
District of Columbia  
CASE NO. 20142  
EXHIBIT NO. 3142

PG 11

9998.02



THE EXTERIOR ELEVATIONS, INCLUDING DOOR AND WINDOW SIZES AND LOCATIONS, THE INTERIOR PARTITIONS LOCATIONS, THE NUMBER, SIZE, AND LOCATIONS OF RESIDENTIAL UNITS, STAIRS, AND ELEVATORS, ARE PRELIMINARY AND ARE SHOWN FOR ILLUSTRATIVE PURPOSES ONLY. THE FINAL LAYOUTS MAY VARY.



PROPOSED PLAN- 3RD - 6TH FLOOR  
SCALE: 1'-0"=1/16"

3401 WATER STREET NW  
BZA SUBMISSION

01.15.2020

1825 K STREET, NW SUITE 300 WASHINGTON D.C. 20006



PG 12



9998.02

# C & O CANAL BELOW

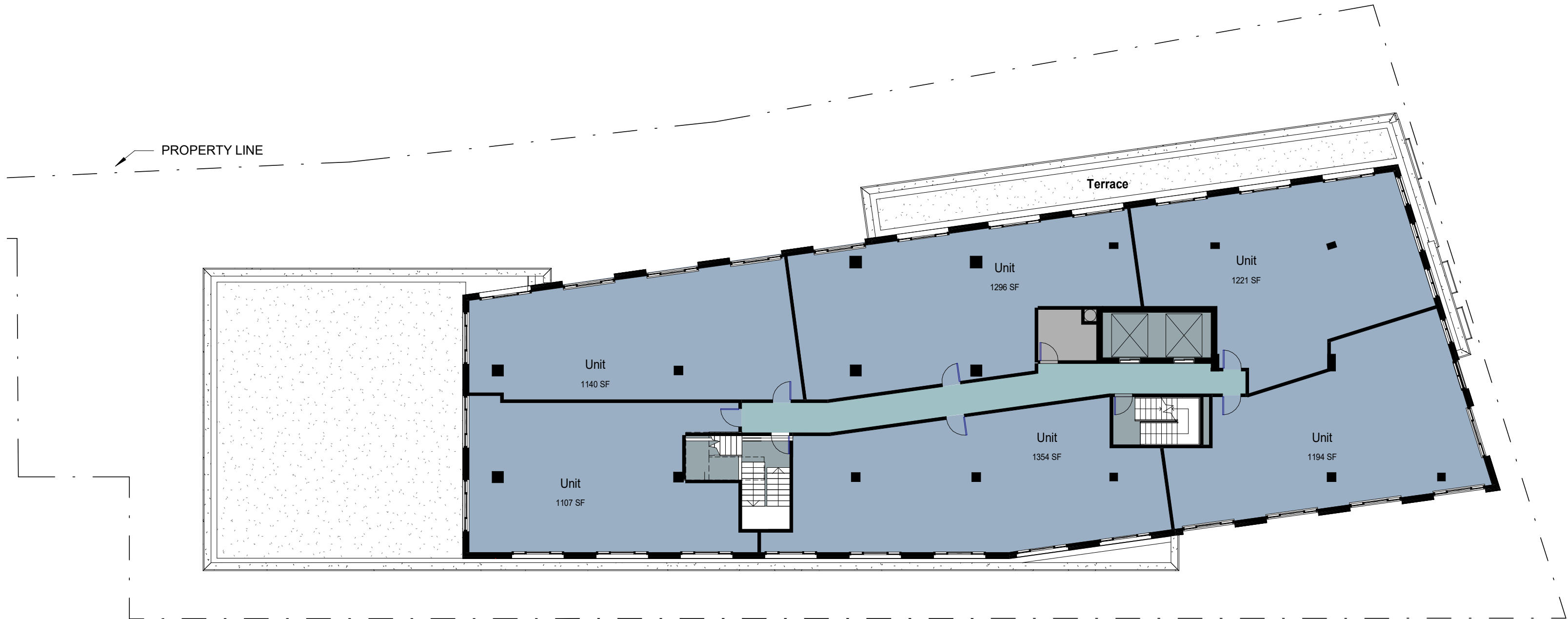

# WATER STREET BELOW

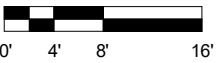

THE EXTERIOR ELEVATIONS, INCLUDING DOOR AND WINDOW SIZES AND LOCATIONS, THE INTERIOR PARTITIONS LOCATIONS, THE NUMBER, SIZE, AND LOCATIONS OF RESIDENTIAL UNITS, STAIRS, AND ELEVATORS, ARE PRELIMINARY AND ARE SHOWN FOR ILLUSTRATIVE PURPOSES ONLY. THE FINAL LAYOUTS MAY VARY.



PROPOSED PLAN- 7TH FLOOR  
SCALE: 1'-0"=1/16"

3401 WATER STREET NW  
BZA SUBMISSION

01.15.2020

1825 K STREET, NW SUITE 300 WASHINGTON D.C. 20006



PG 13



9998.02

# C & O CANAL BELOW

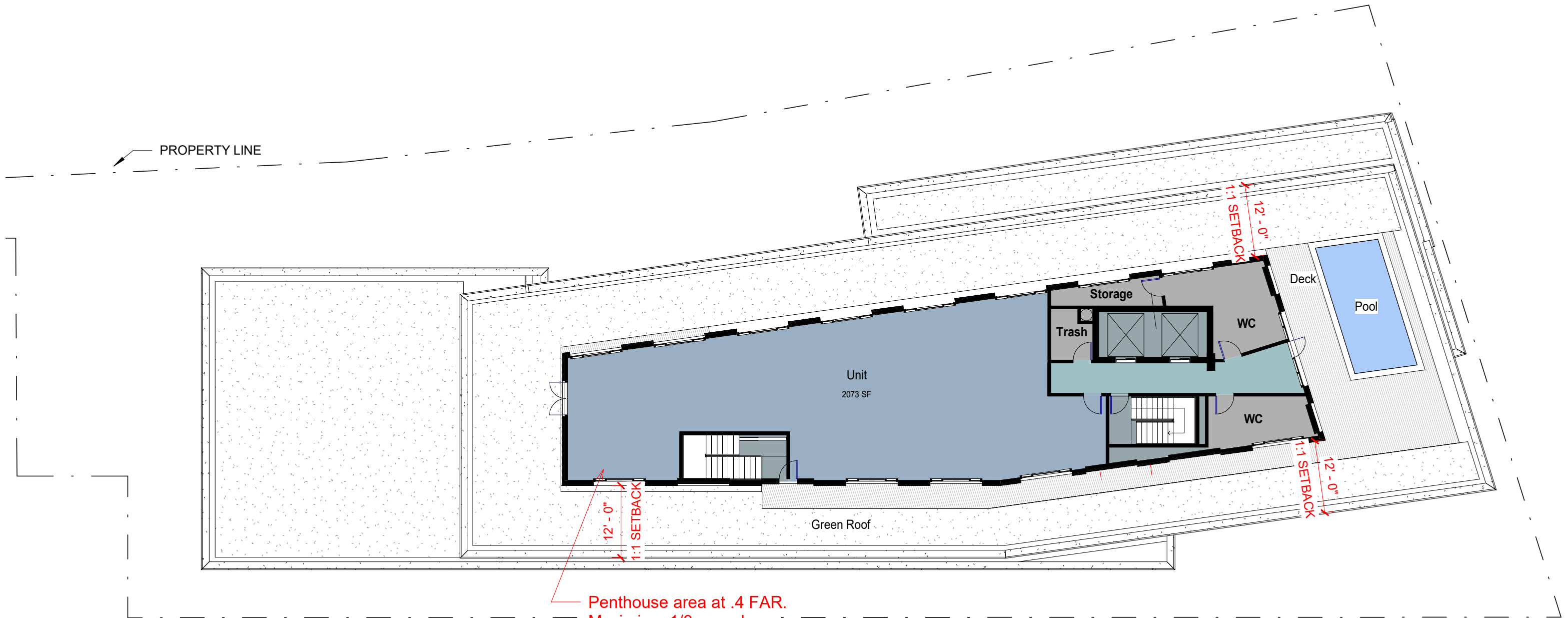

Penthouse area at .4 FAR.  
Maximum 1/3 area does  
not apply. Must comply  
with IZ 1500.11, 1001.5,  
1001.2.d Subtitle C.

# WATER STREET BELOW

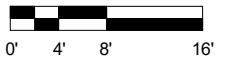

THE EXTERIOR ELEVATIONS, INCLUDING DOOR AND WINDOW SIZES AND LOCATIONS, THE INTERIOR PARTITIONS LOCATIONS, THE NUMBER, SIZE, AND LOCATIONS OF RESIDENTIAL UNITS, STAIRS, AND ELEVATORS, ARE PRELIMINARY AND ARE SHOWN FOR ILLUSTRATIVE PURPOSES ONLY. THE FINAL LAYOUTS MAY VARY.



9998.02

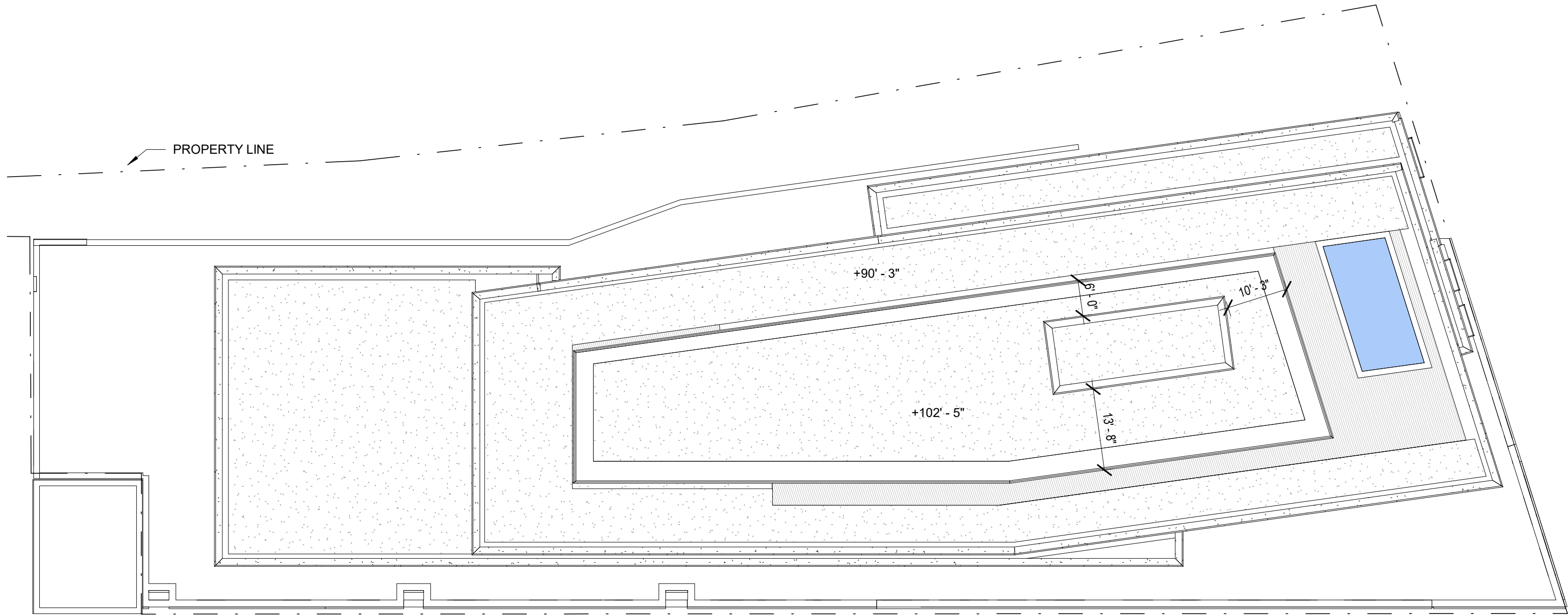

THE EXTERIOR ELEVATIONS, INCLUDING DOOR AND WINDOW SIZES AND LOCATIONS, THE INTERIOR PARTITIONS LOCATIONS, THE NUMBER, SIZE, AND LOCATIONS OF RESIDENTIAL UNITS, STAIRS, AND ELEVATORS, ARE PRELIMINARY AND ARE SHOWN FOR ILLUSTRATIVE PURPOSES ONLY. THE FINAL LAYOUTS MAY VARY.



PROPOSED UPPER ROOF PLAN  
SCALE: 1'-0"=1/16"

3401 WATER STREET NW  
BZA SUBMISSION

01.15.2020

1825 K STREET, NW SUITE 300 WASHINGTON D.C. 20006



PG 15



BBGM

9998.02

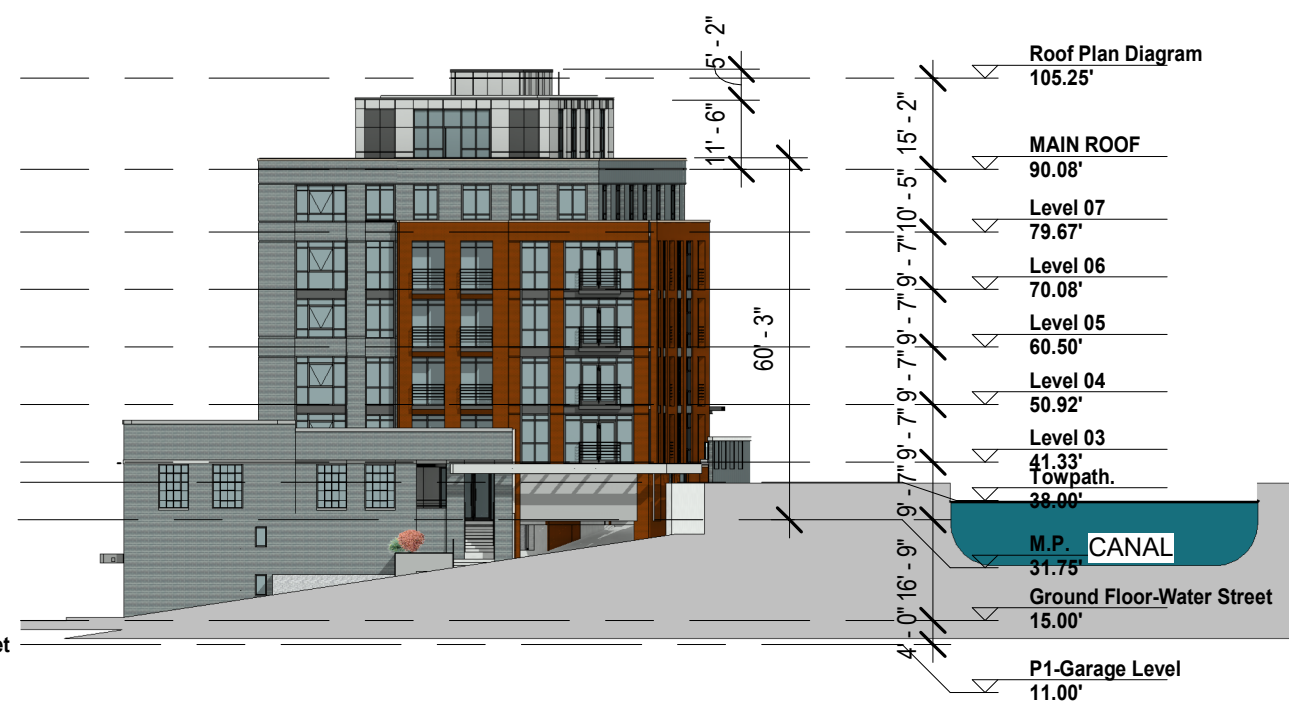

THE EXTERIOR ELEVATIONS, INCLUDING DOOR AND WINDOW SIZES AND LOCATIONS, THE INTERIOR PARTITIONS LOCATIONS, THE NUMBER, SIZE, AND LOCATIONS OF RESIDENTIAL UNITS, STAIRS, AND ELEVATORS, ARE PRELIMINARY AND ARE SHOWN FOR ILLUSTRATIVE PURPOSES ONLY. THE FINAL LAYOUTS MAY VARY.



Roof Plan Diagram	105.25'
MAIN ROOF	90.08'
Level 07	79.67'
Level 06	70.08'
Level 05	60.50'
Level 04	50.92'
Level 03	41.33'
M.P.	31.75'
Ground Floor-Water Street	15.00'

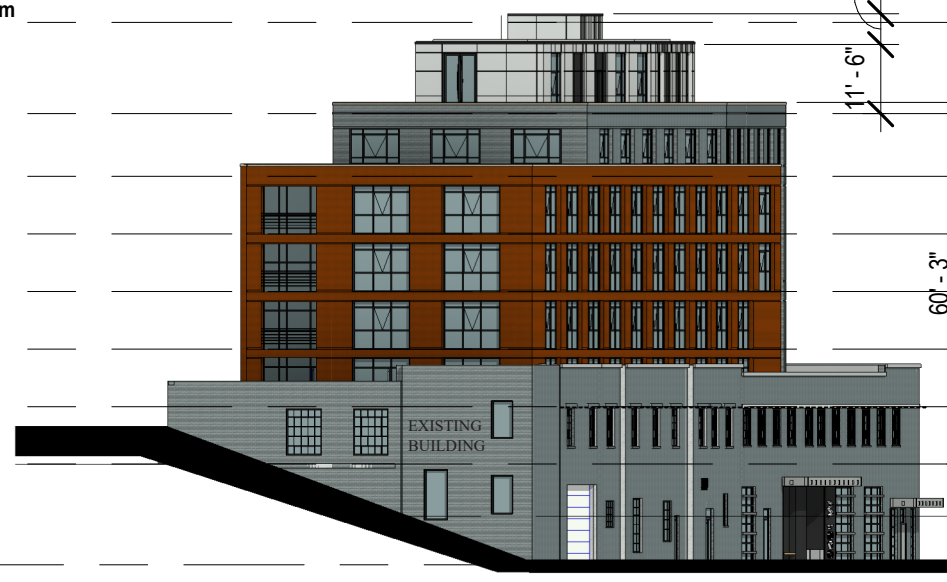

Roof Plan Diagram	105.25'
MAIN ROOF	90.08'
Level 07	79.67'
Level 06	70.08'
Level 05	60.50'
Level 04	50.92'
Level 03	41.33'
M.P.	31.75'
Ground Floor-Water Street	15.00'

THE EXTERIOR ELEVATIONS, INCLUDING DOOR AND WINDOW SIZES AND LOCATIONS, THE INTERIOR PARTITIONS LOCATIONS, THE NUMBER, SIZE, AND LOCATIONS OF RESIDENTIAL UNITS, STAIRS, AND ELEVATORS, ARE PRELIMINARY AND ARE SHOWN FOR ILLUSTRATIVE PURPOSES ONLY. THE FINAL LAYOUTS MAY VARY.



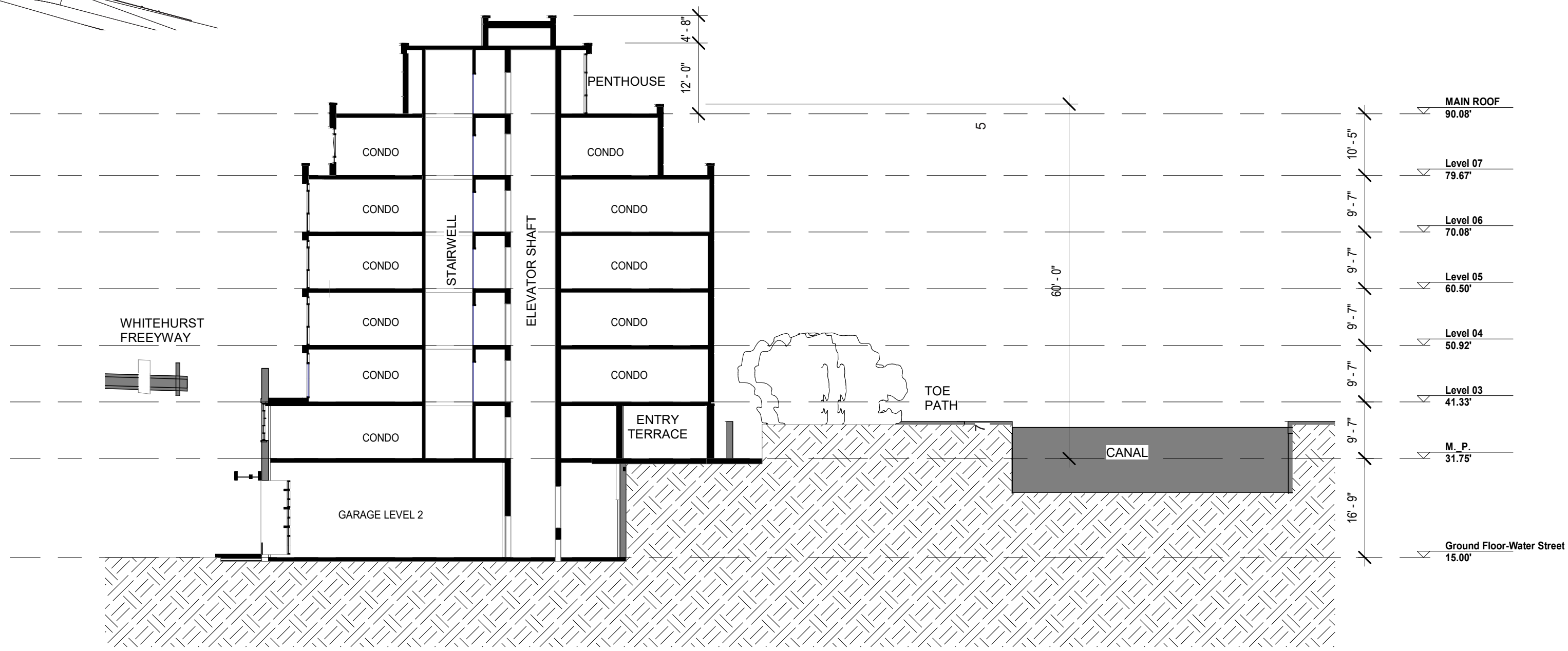
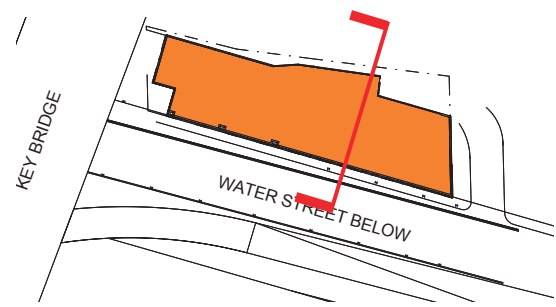

WHITEHURST FREEYWAY

EXISTING STRUCTURE TO REMAIN
   
 NEW STRUCTURE

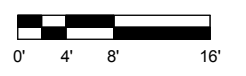

THE EXTERIOR ELEVATIONS, INCLUDING DOOR AND WINDOW SIZES AND LOCATIONS, THE INTERIOR PARTITIONS LOCATIONS, THE NUMBER, SIZE, AND LOCATIONS OF RESIDENTIAL UNITS, STAIRS, AND ELEVATORS, ARE PRELIMINARY AND ARE SHOWN FOR ILLUSTRATIVE PURPOSES ONLY. THE FINAL LAYOUTS MAY VARY.

9998.02



CROSS SECTION  
SCALE: 1'-0"=1/16"

3401 WATER STREET NW  
BZA SUBMISSION

01.15.2020

1825 K STREET, NW SUITE 300 WASHINGTON D.C. 20006 PG 18





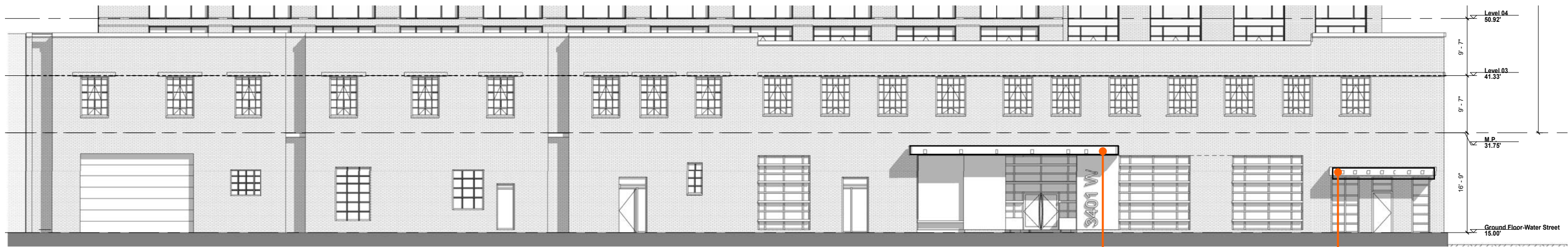
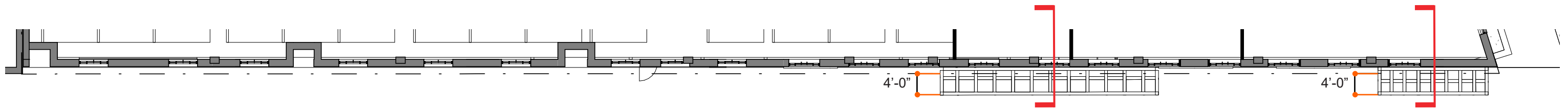
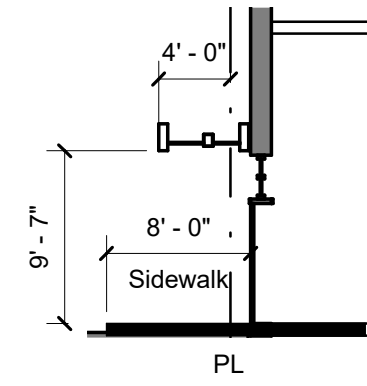
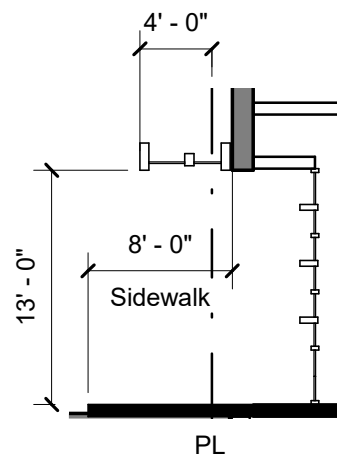

CANOPY PROJECTIONS 4' DEEP

9998.02



SOUTH ELEVATION  
SCALE: 1'-0"=1/32"

3401 WATER STREET NW  
BZA SUBMISSION

03.09.2020

1825 K STREET, NW SUITE 300 WASHINGTON D.C. 20006 PG 19



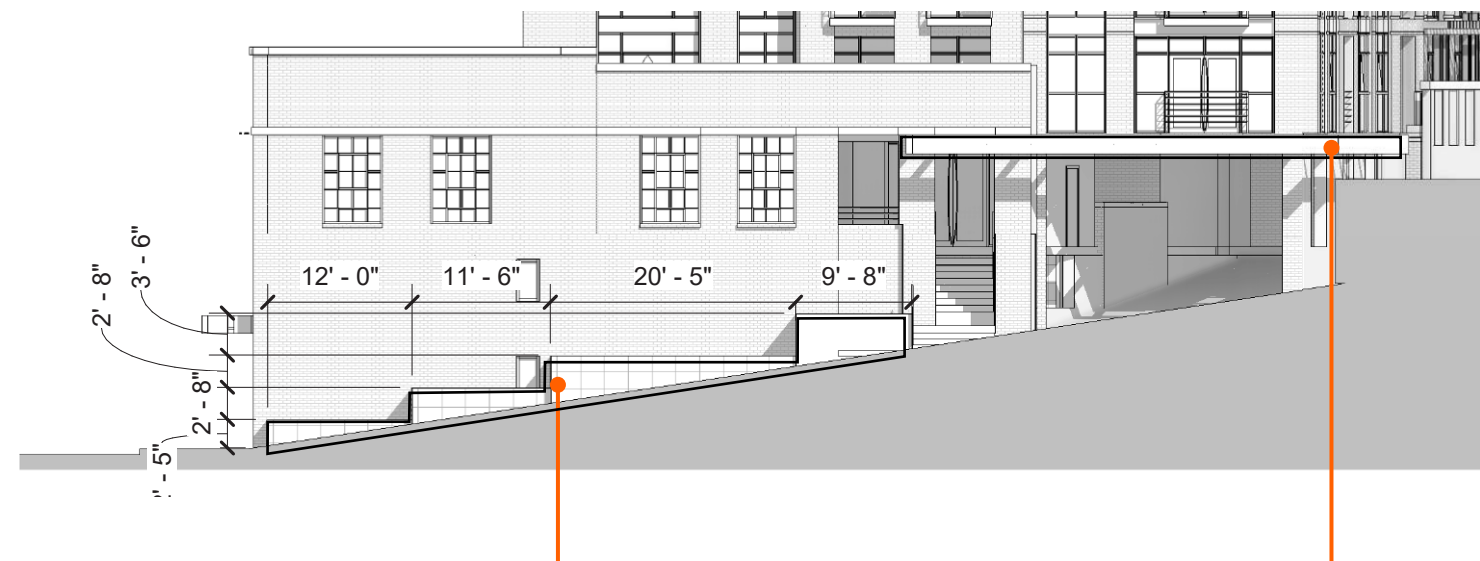
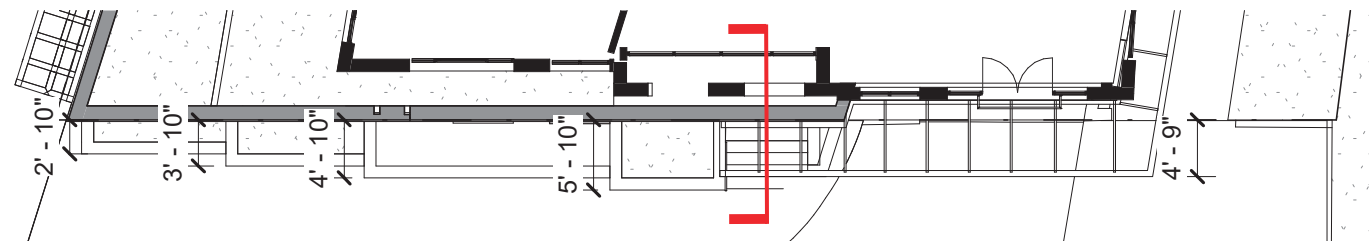
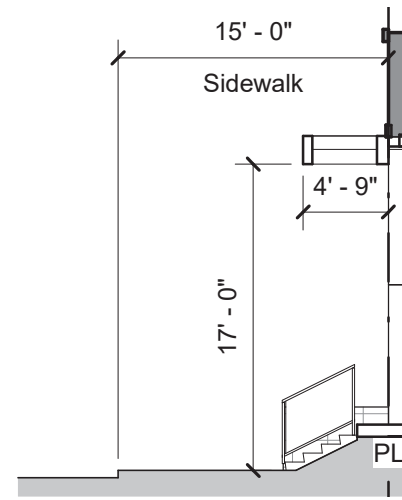

PLANTER PROJECTIONS FROM 2'-10 TO 5'-10" DEEP

CANOPY PROJECTION 4'-9" DEEP