

OFFICIAL
 PERMIT APPROVAL



OFFICIAL PERMIT APPROVAL

- These plans are conditioned on the permittee's compliance with any conditions of the permit. It is the permittee's responsibility to construct in accordance with the approved plans and does not constitute a guarantee, warranty, or assurance of performance.
- All work must be done in strict accordance with the approved plans. No changes or alterations shall be made to the approved plans without the prior written approval of the Department of Public Works.
- Issuance of permit does not prevent field inspections from ordering corrections to meet local codes when such are noted during inspection.
- No on-site changes or modifications shall be made without the prior written approval of the Department of Public Works.
- This permit does not include approval for any work requiring a separate permit, such as plumbing, electrical or fire.

MCMILLAN
 SITE DEVELOPMENT
 PACKAGE
 LOT 800; SQUARE 3128
 WASHINGTON, DC

OWNER
 DISTRICT OF COLUMBIA
 Office of the Deputy Mayor for Planning &
 Economic Development
 1350 Pennsylvania Ave. NW
 Washington, DC 20004
 Tel. (202) 727-6365

DEVELOPER
 VISION MCMILLAN PARTNERS
 1508 U Street NW
 Washington, DC 20009
 Tel. (202) 462-1092

CONSULTANTS
 ARCHITECT
 PERKINS EASTMAN DC
 1250 23rd Street NW
 Suite 475
 Washington, DC 20037
 Tel. (202) 495-7430

LANDSCAPE ARCHITECT
 NELSON BYRD WOLTZ
 310 East Market Street
 Charlottesville, VA 22902
 Tel. (434) 984-1358

STRUCTURAL ENGINEER
 SILMAN ASSOCIATES
 1053 31st Street NW
 Washington, DC 20007
 Tel. (202) 331-6230

MEP ENGINEER
 SETTY & ASSOCIATES
 INTERNATIONAL, PLLC
 5185 MacArthur Boulevard NW
 Suite 220
 Washington, DC 20016
 Tel. (202) 393-1523

LIGHTING DESIGN
 STROIK LIGHTING DESIGN
 1470 Waggaman Circle
 McLean, VA 22101
 Tel. (703) 829-0548

HISTORIC PRESERVATION
 EHT TRACERIES
 1121 5th Street NW
 Washington, DC 20001
 Tel. (202) 393-1199

CIVIL ENGINEER
 BOWMAN CONSULTING DC PC
 888 17th Street NW
 Suite 202
 Washington, DC 20006
 Tel. (202) 750-2474

SOE/GEOTECHNICAL ENGINEER
 GEI CONSULTANTS
 1620 I Street NW
 Suite 800
 Washington, DC 20006
 Tel. (202) 828-9510

KEY PLAN

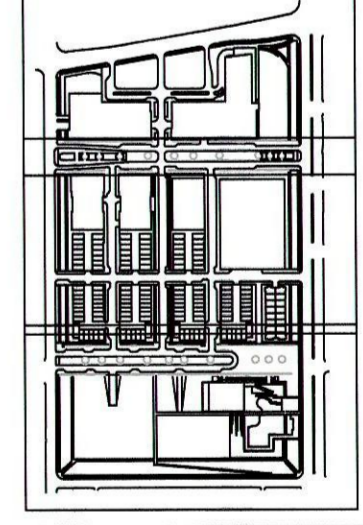

PLAN STATUS	
NO.	DESCRIPTION

PL. DESIGN	TBM DRAWN	GAB CHKO
SCALE		
JOB No. 6266-02-005		
DATE 06/15/16		

SECTIONS
 PACKAGE 3

SOD007_3
 SHEET

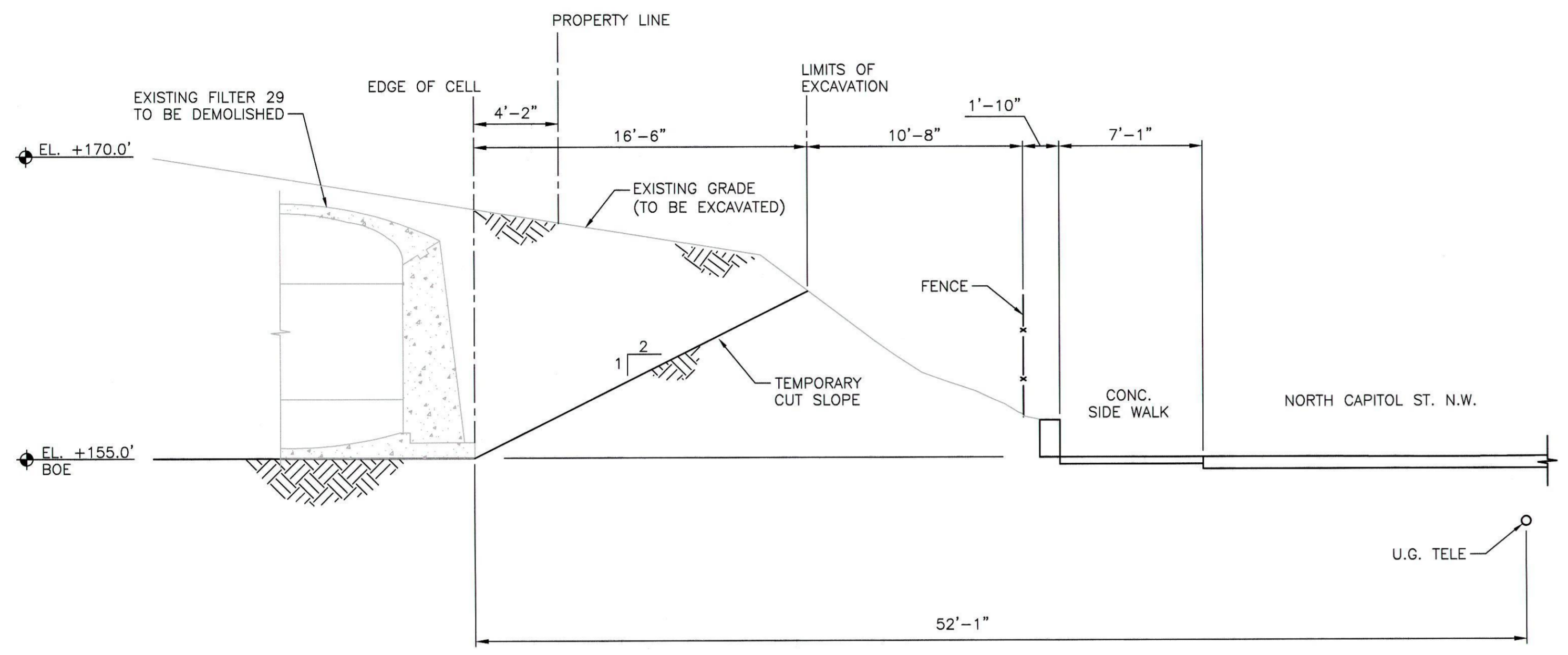
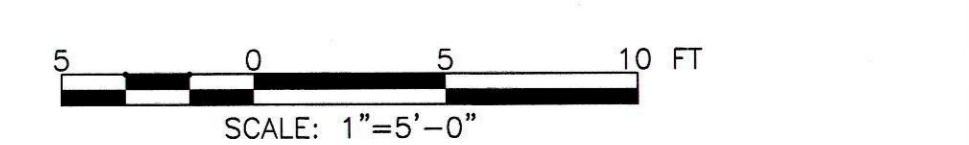

**SECTION 17ASOD007_3
 SOD005_3**
 SCALE: 1"=5'-0"

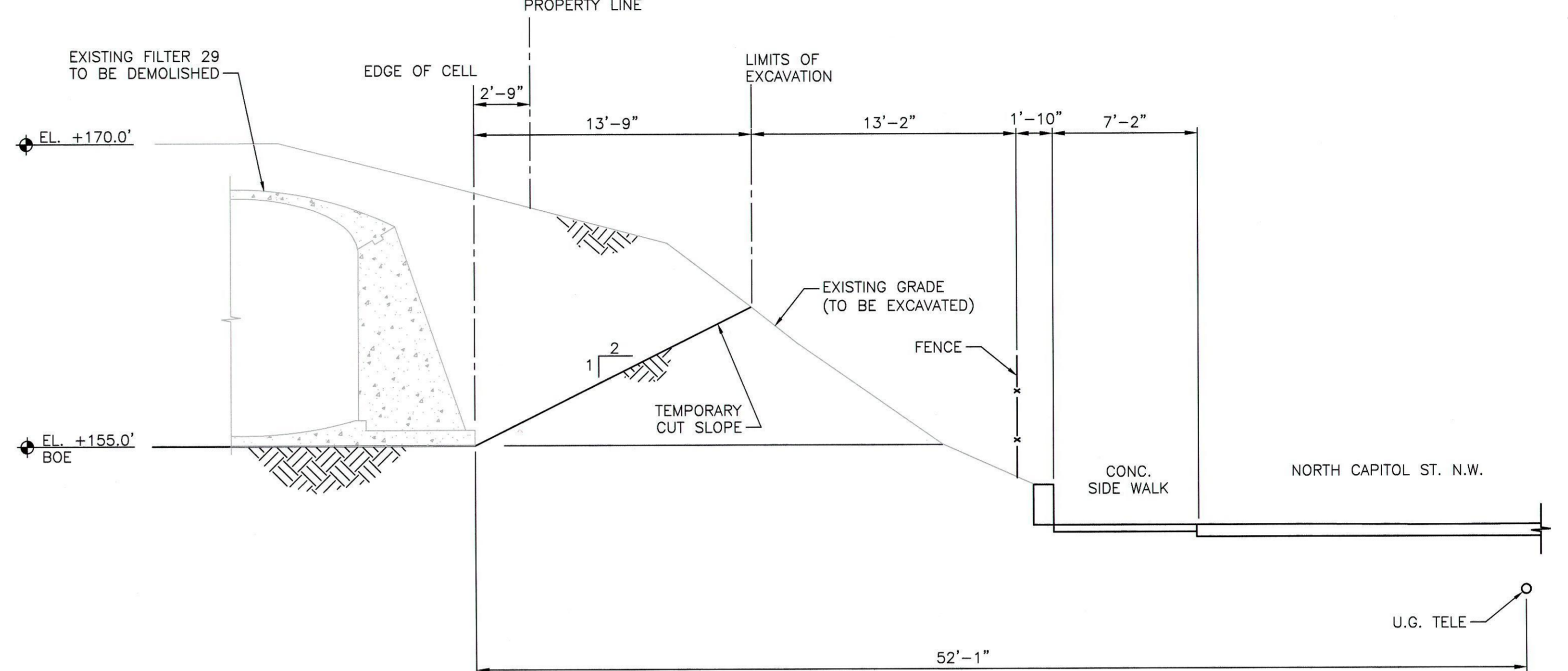

**SECTION 17BSOD007_3
 SOD005_3**
 SCALE: 1"=5'-0"

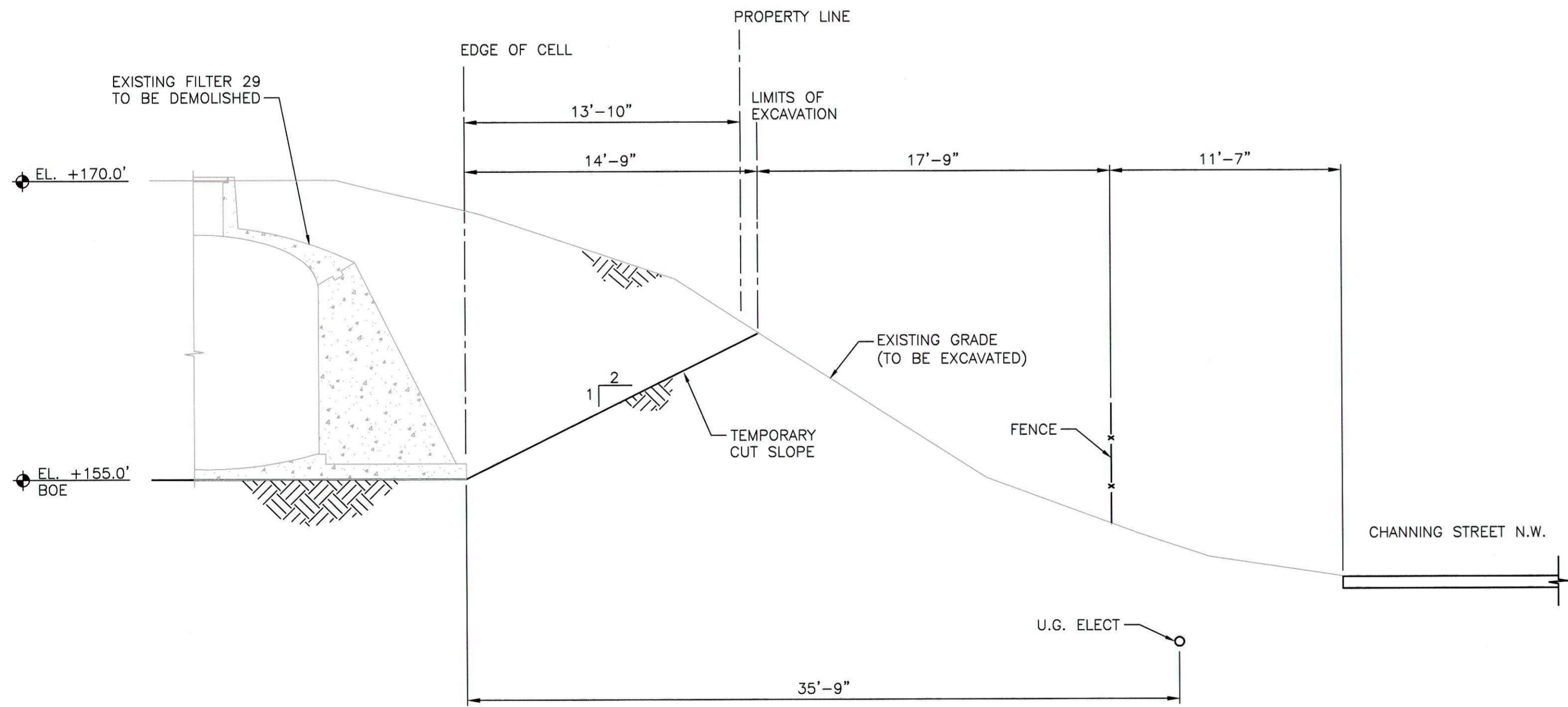

**SECTION 18SOD007_3
 SOD005_3**
 SCALE: 1"=5'-0"

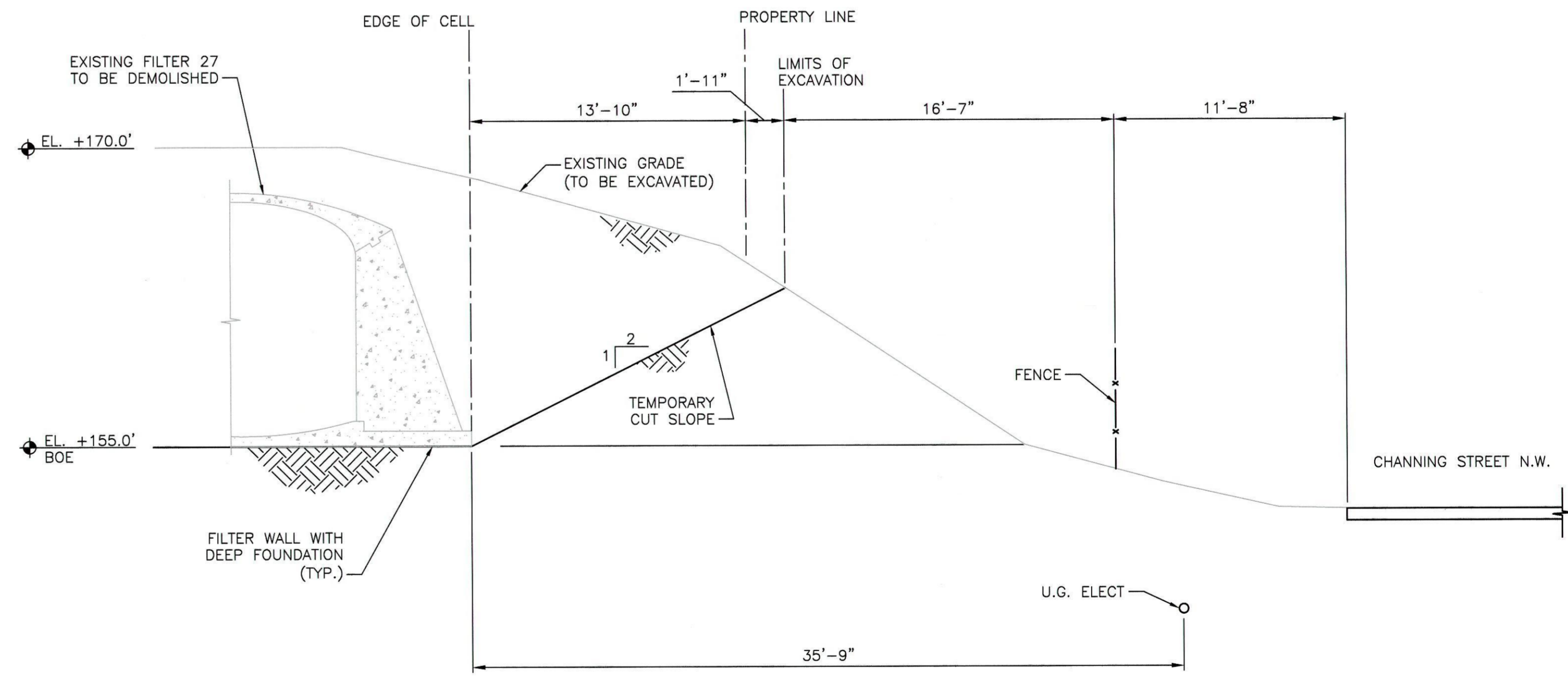

**SECTION 19SOD007_3
 SOD005_3**
 SCALE: 1"=5'-0"

NOTE:
 1. ALL UTILITIES ARE EXISTING. LOCATIONS AND ELEVATIONS ARE APPROXIMATE.
 2. ALL FEATURES TO REMAIN UNLESS NOTED OTHERWISE.

CAUTION!
 THE LOCATIONS OF ALL EXISTING UNDERGROUND UTILITIES SHOWN ON THIS PLAN ARE BASED UPON ABOVE GROUND EVIDENCE (INCLUDING, BUT NOT LIMITED TO, MANHOLES, INLETS, VALVES, AND MARKS MADE UPON THE GROUND BY OTHERS) AND ARE SPECULATIVE IN NATURE. THERE MAY ALSO BE OTHER EXISTING UNDERGROUND UTILITIES FOR WHICH THERE IS NO ABOVE GROUND EVIDENCE OR FOR WHICH NO ABOVE GROUND EVIDENCE WAS OBSERVED. THE EXACT LOCATIONS OF SAID EXISTING UNDERGROUND UTILITIES SHALL BE VERIFIED BY THE CONTRACTOR PRIOR TO ANY AND ALL CONSTRUCTION.

MISS UTILITY
 CALL DC ONE CALL "DOC" AT 1-800-257-7777 48 HOURS PRIOR TO THE START OF WORK. THE EXCAVATOR MUST NOTIFY ALL PUBLIC UTILITY COMPANIES WITH UNDERGROUND FACILITIES IN THE AREA OF PROPOSED EXCAVATION AND HAVE THOSE FACILITIES LOCATED BY THE UTILITY COMPANIES PRIOR TO COMMENCING EXCAVATION. THE EXCAVATOR IS RESPONSIBLE FOR COMPLIANCE WITH REQUIREMENTS OF THE DISTRICT OF COLUMBIA CODES AND REGULATIONS.

Cad file name: X:\2015\1517010 - Vision McMillan Reserve\CAD\Design\Working\Design Packages\Package 3\SOD006_3 thru SOD007_3 - Cross Sections_Pk 3.dwg 6/14/2016

