

TAB A

SUN STUDY

01-14-2020

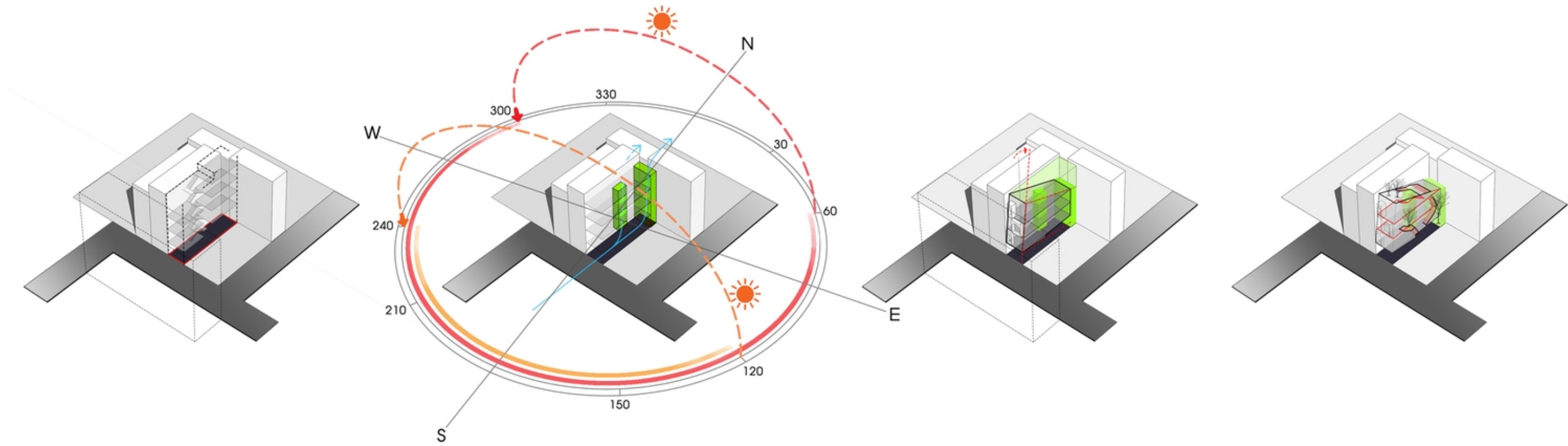

PROJECTED SHADOWS ON THE 21ST OF EACH MONTH AT 11:00AM

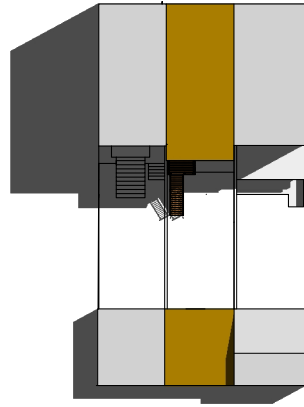
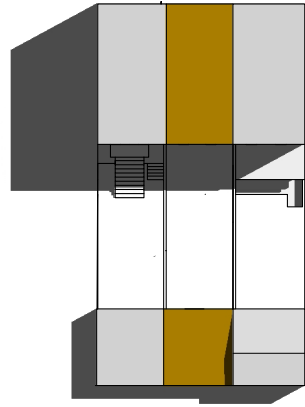
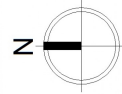

APRIL TIME: 11:00AM

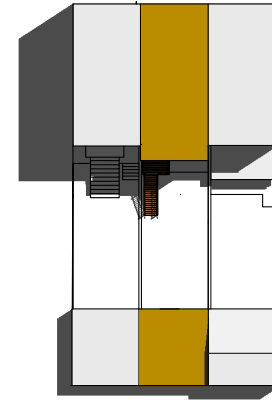
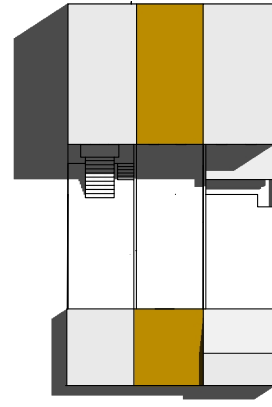

MAY TIME: 11:00AM

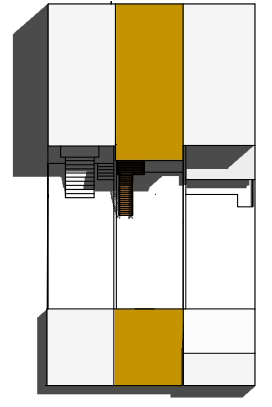
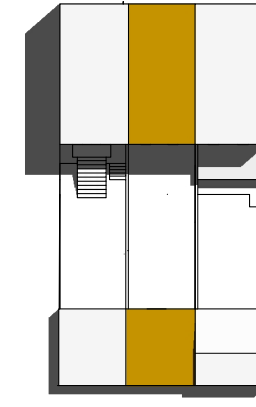

JUNE TIME: 11:00AM

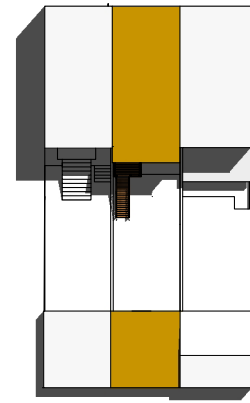
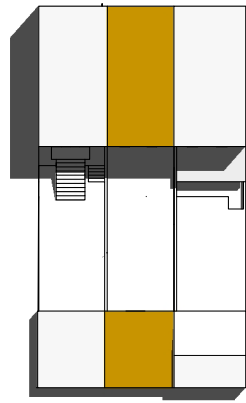

JULY TIME: 11:00AM

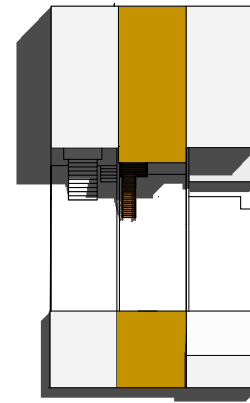
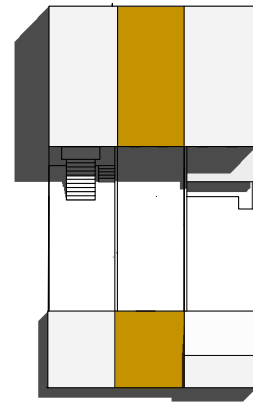

AUGUST TIME: 11:00AM

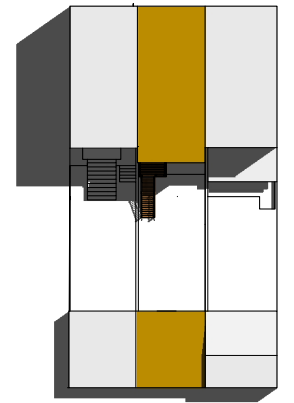
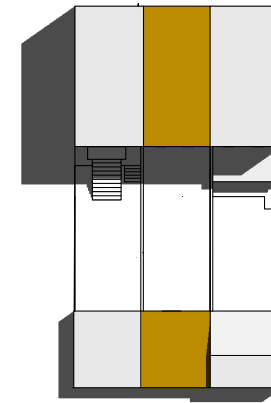

SEPTEMBER TIME: 11:00AM

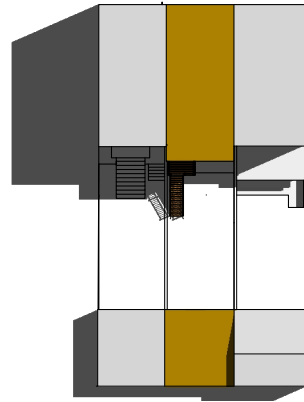
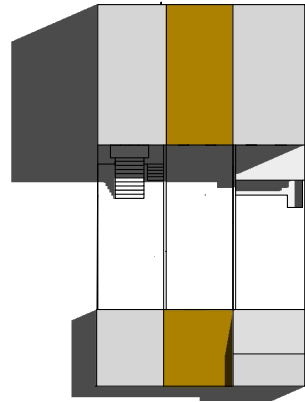

OCTOBER TIME: 11:00AM

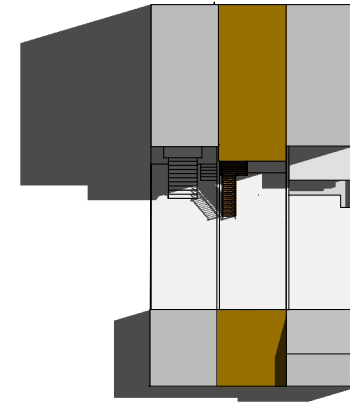
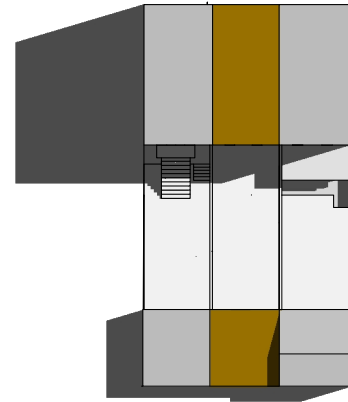

NOVEMBER TIME: 11:00AM

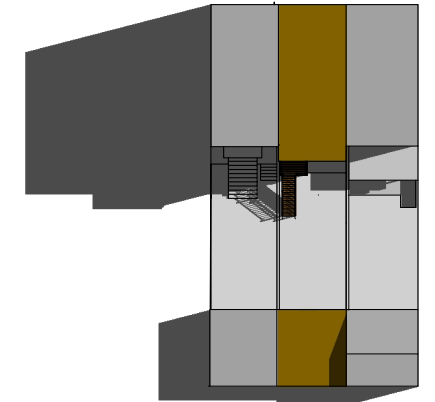
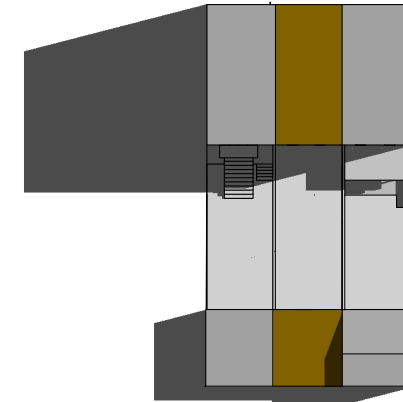

DECEMBER TIME: 11:00AM

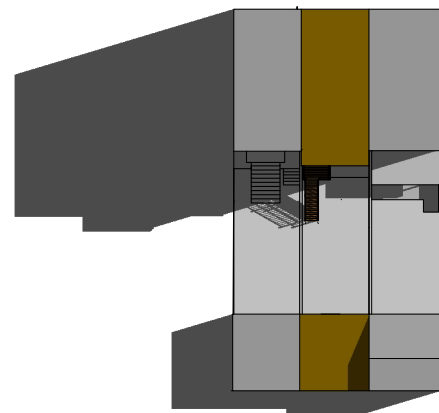
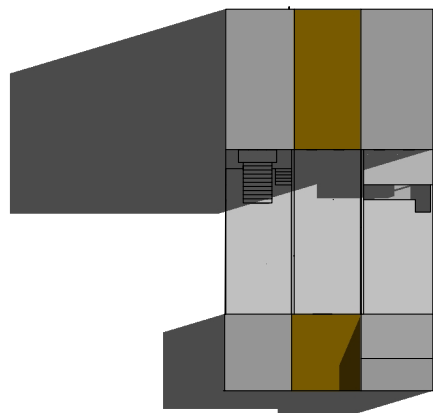

JANUARY TIME: 11:00AM

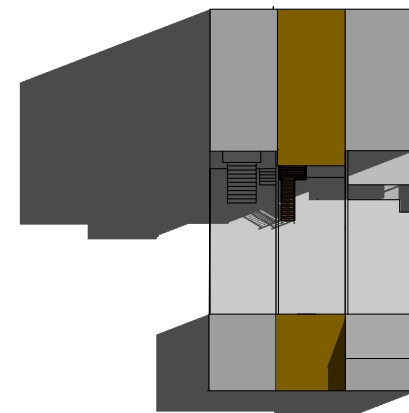
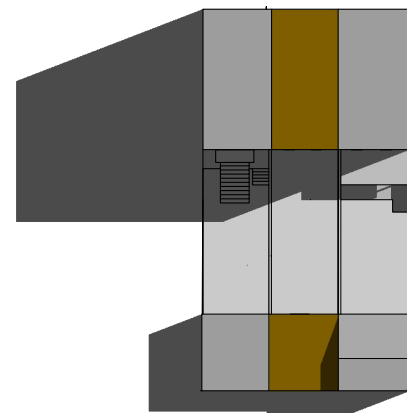

FEBRUARY TIME: 11:00AM

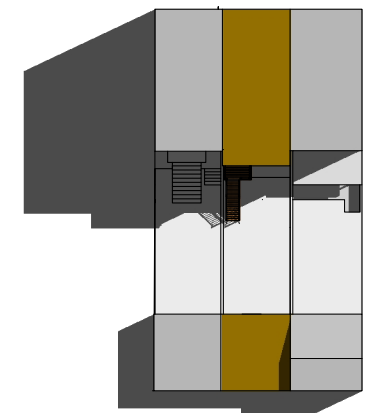
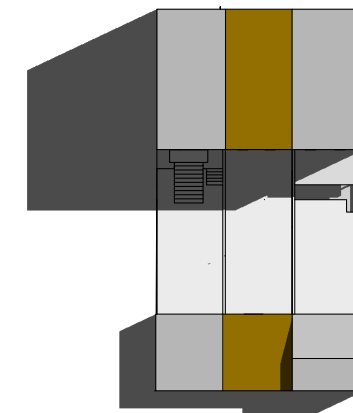

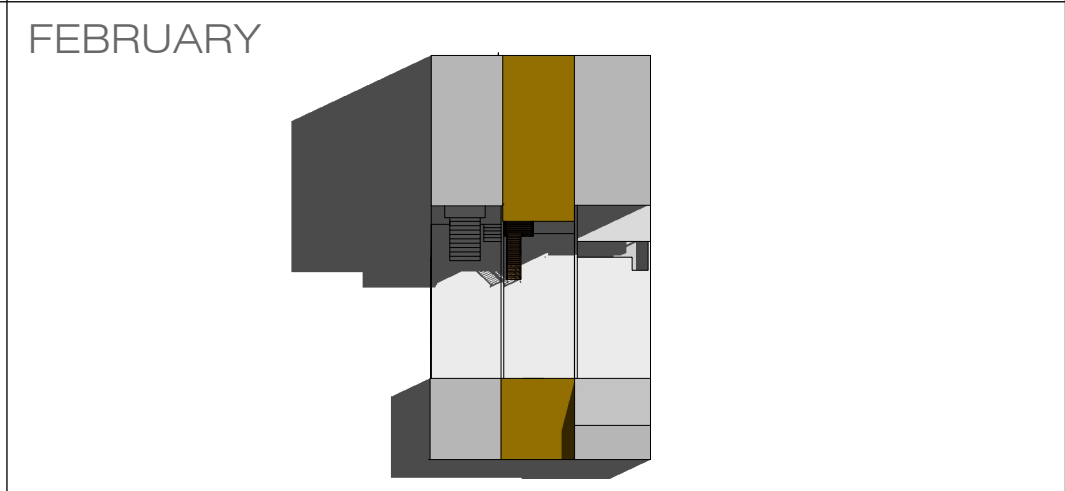
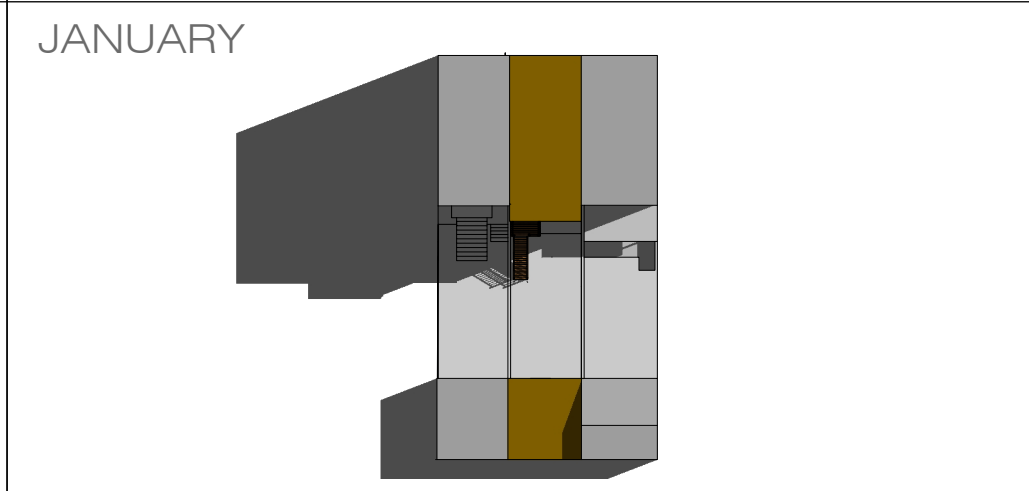
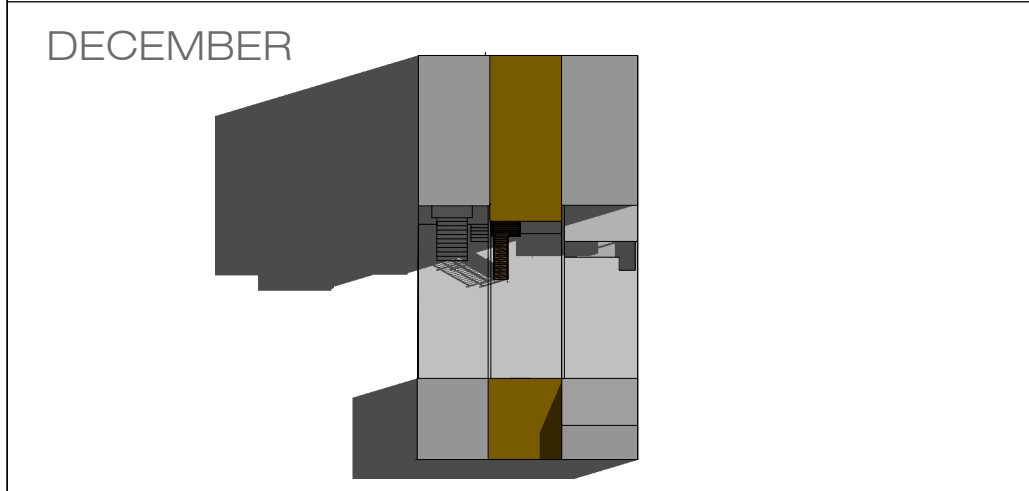
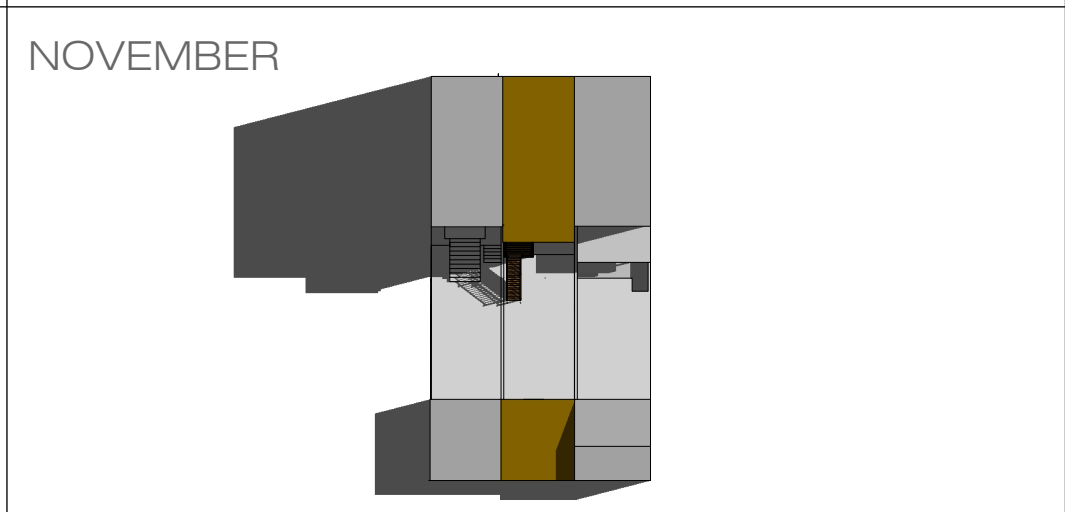
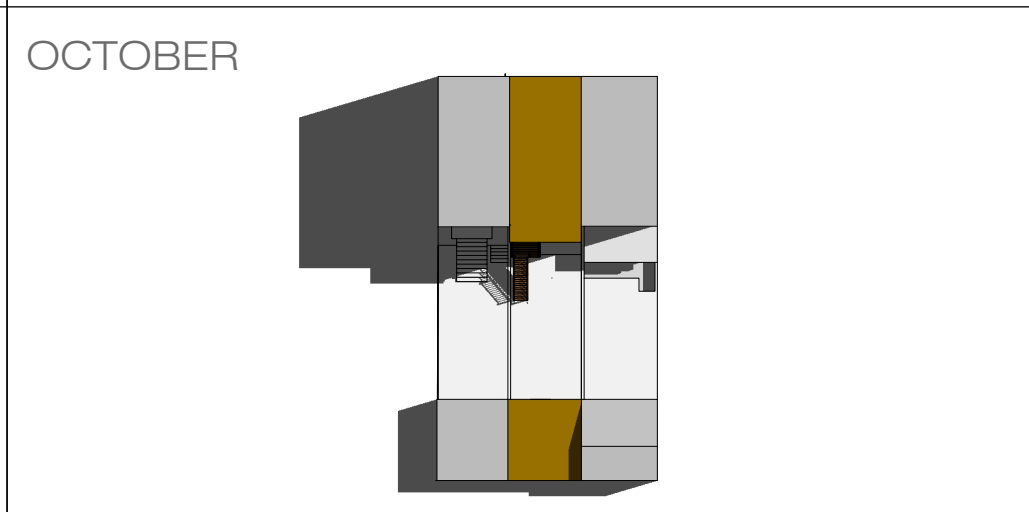
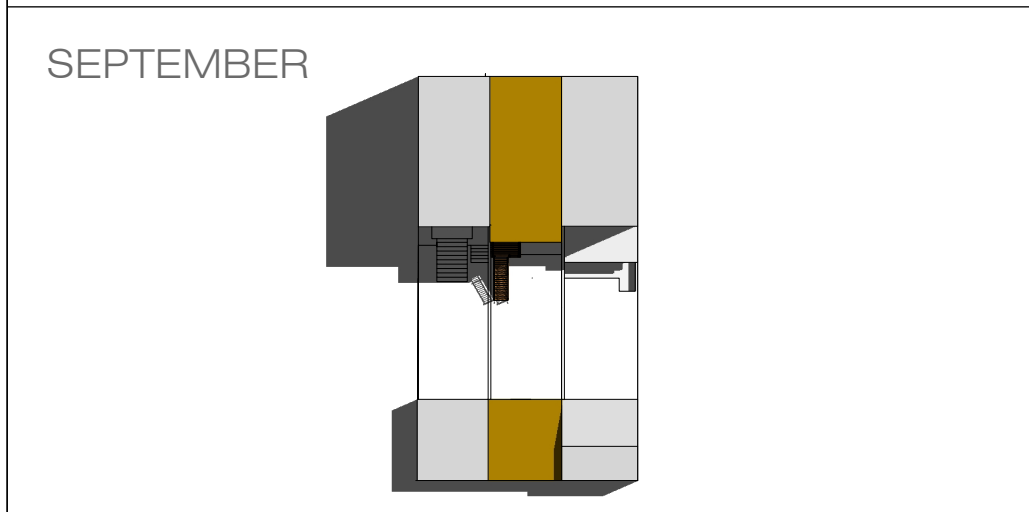
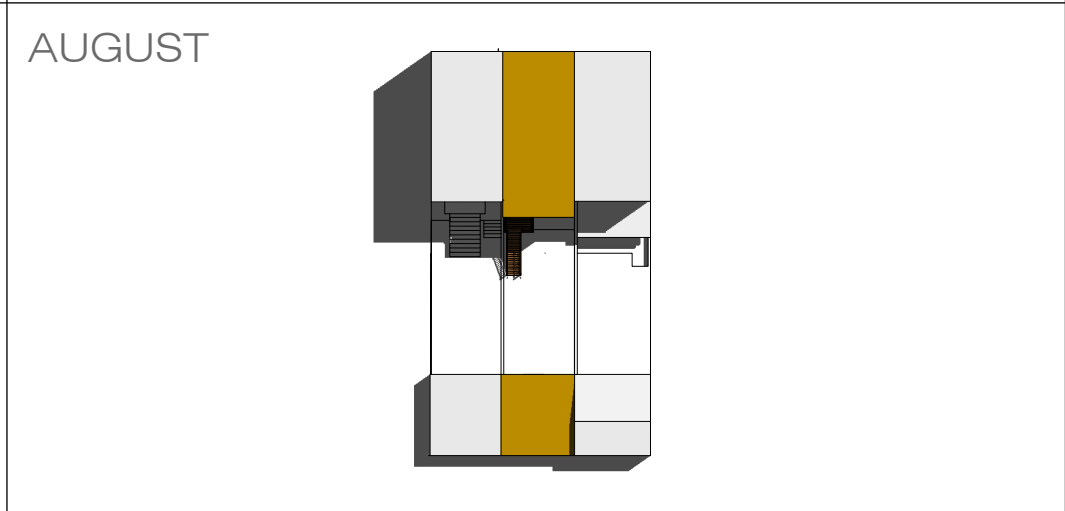
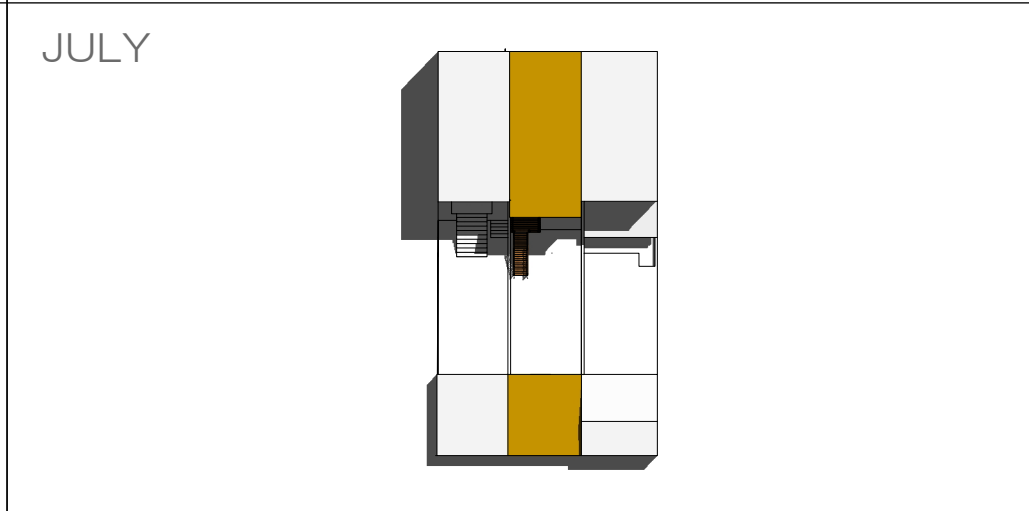
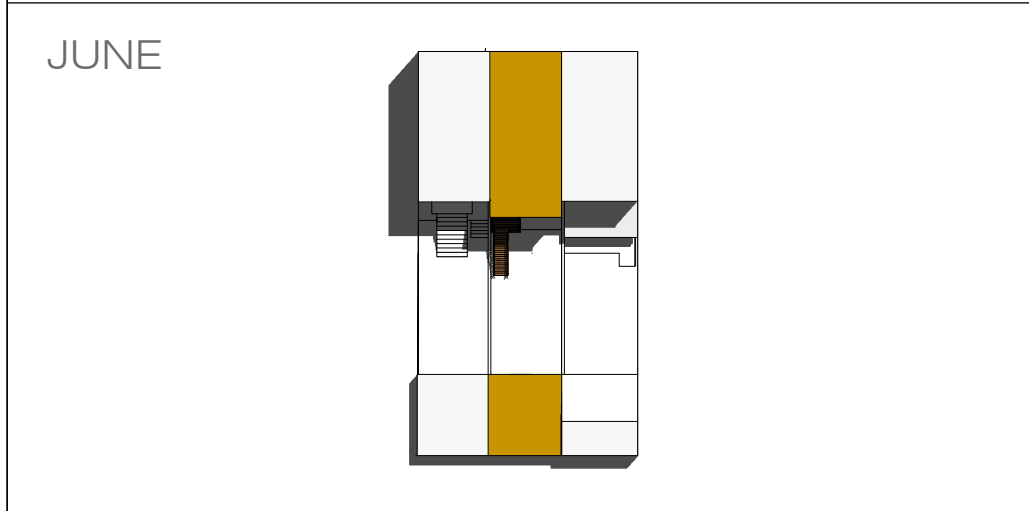
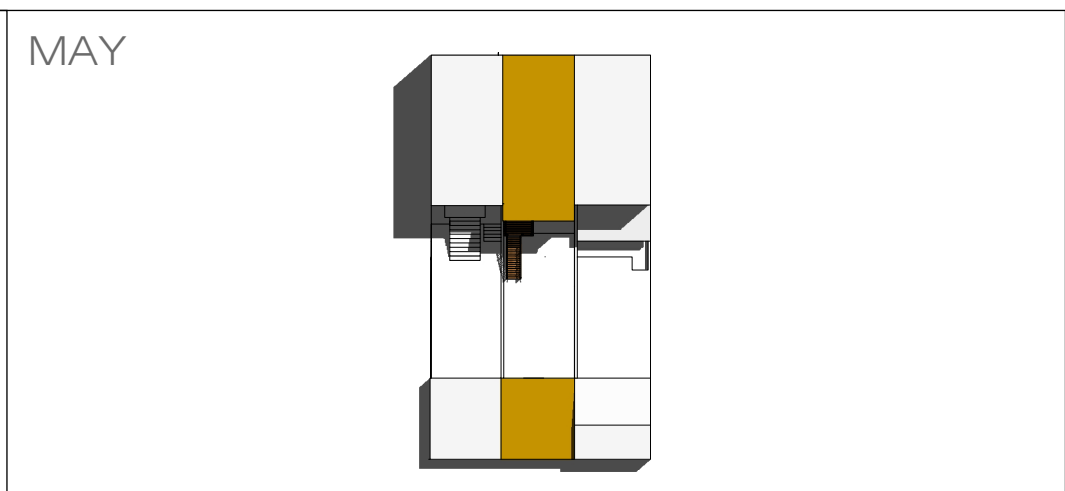
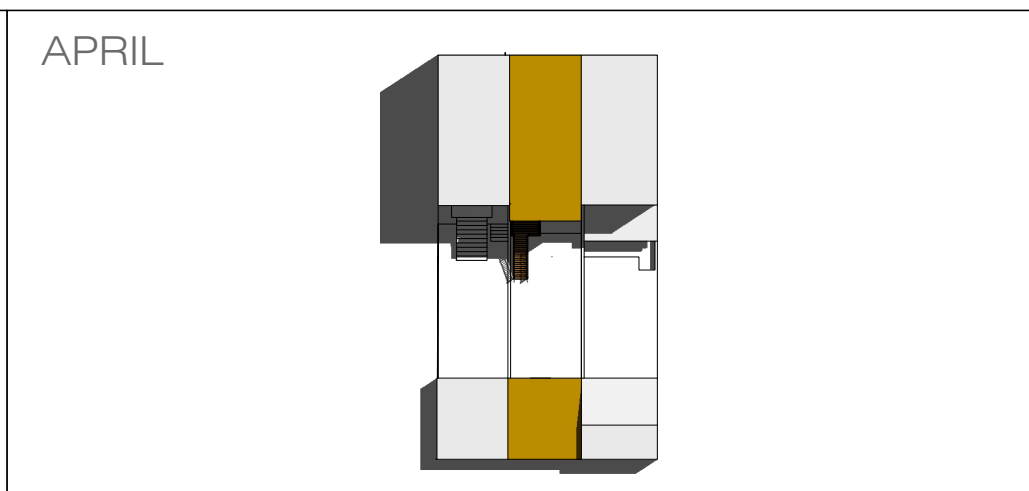
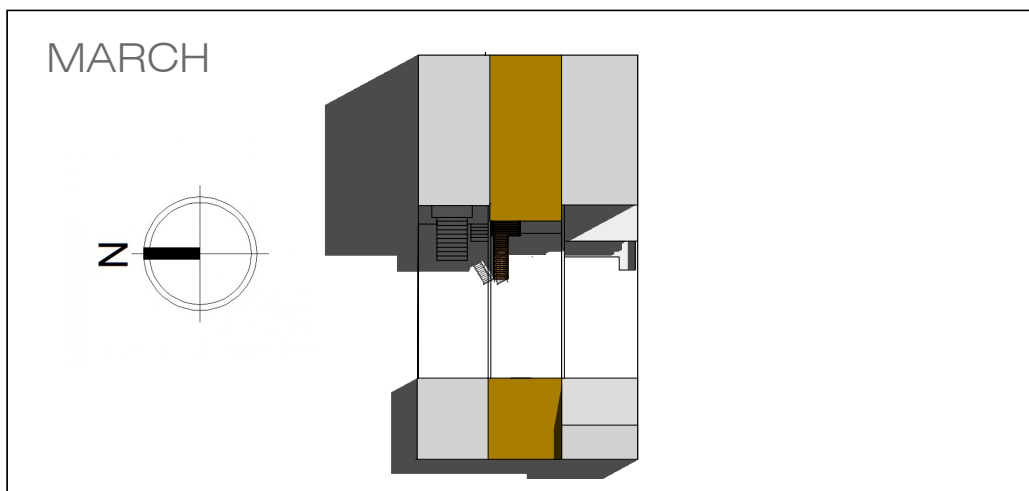

MARCH
SPRING

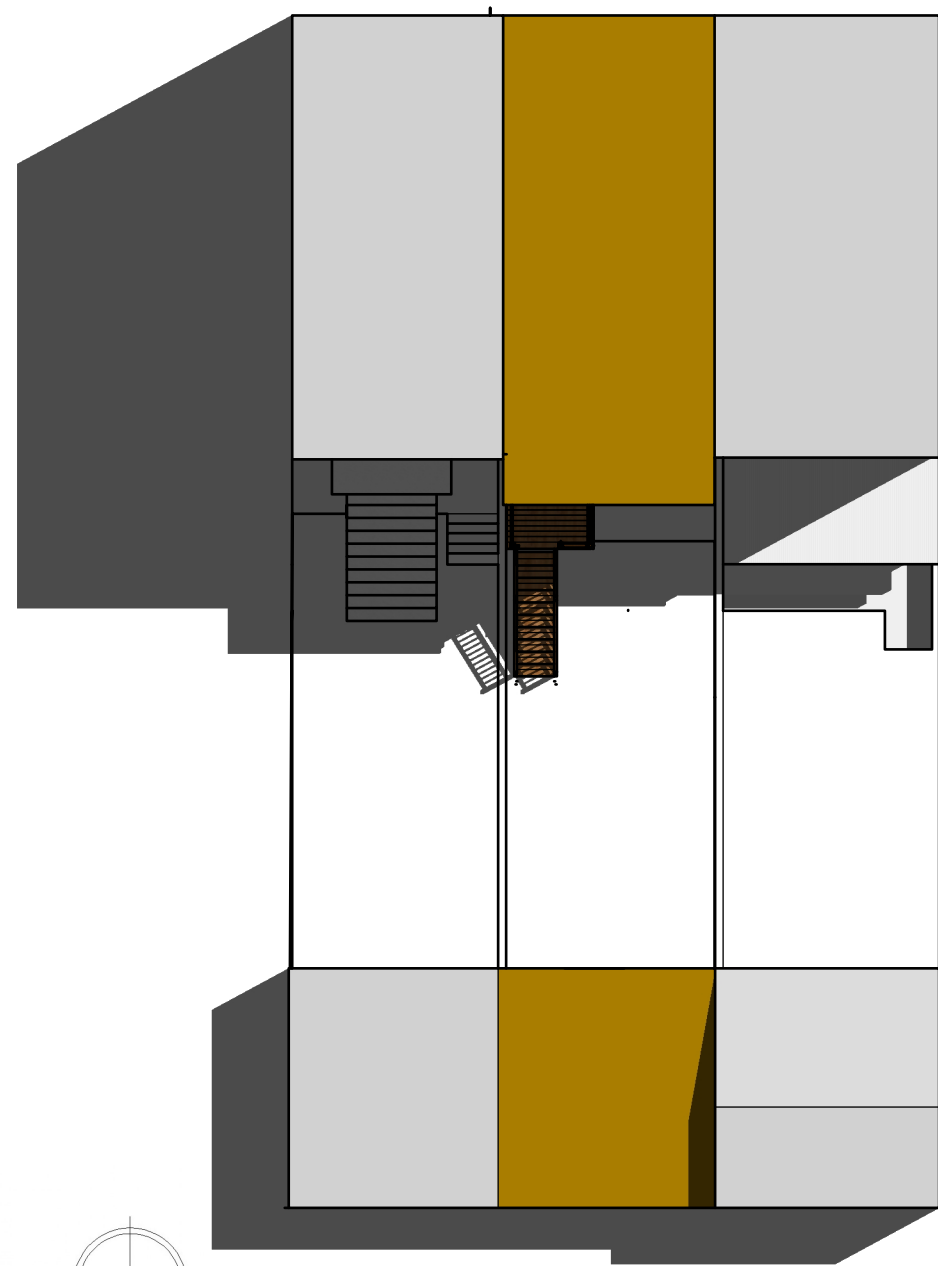

APRIL
SPRING

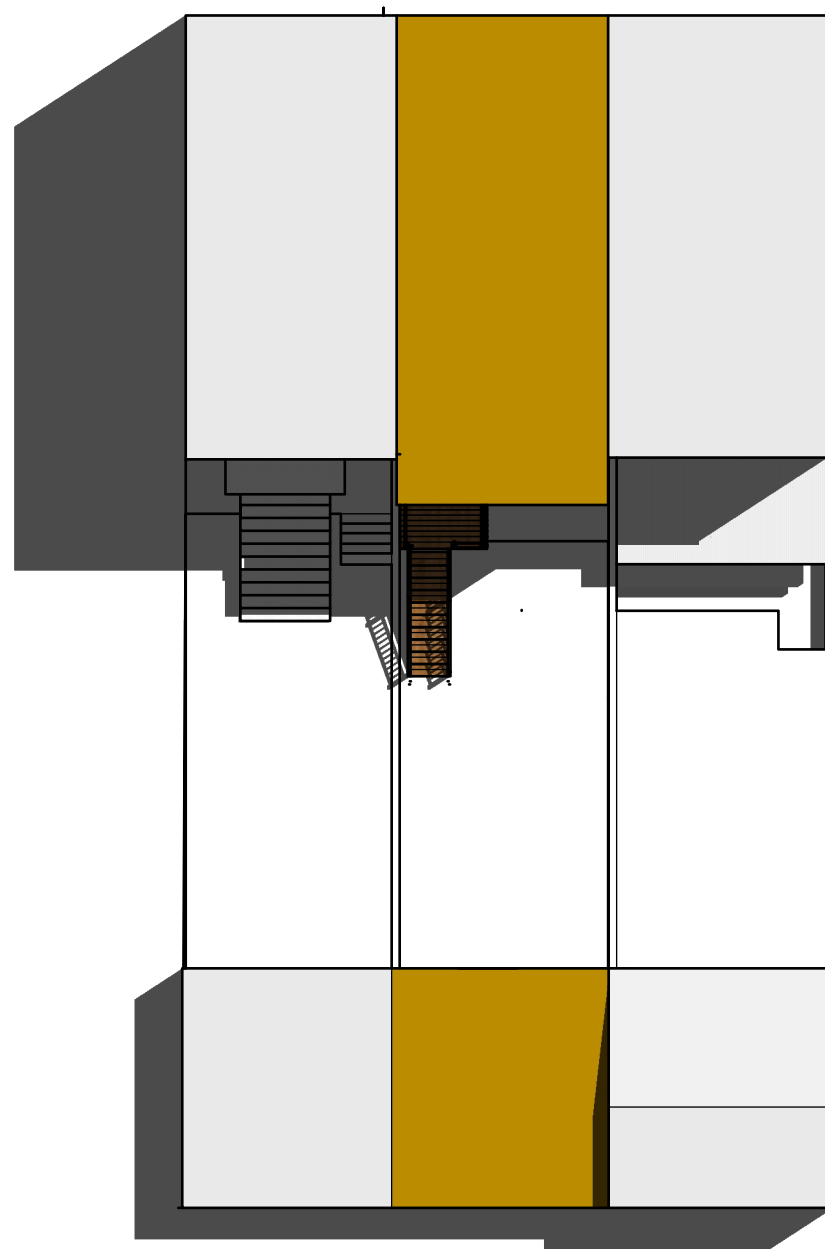

MAY
SPRING

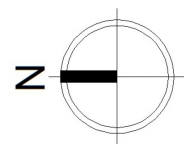
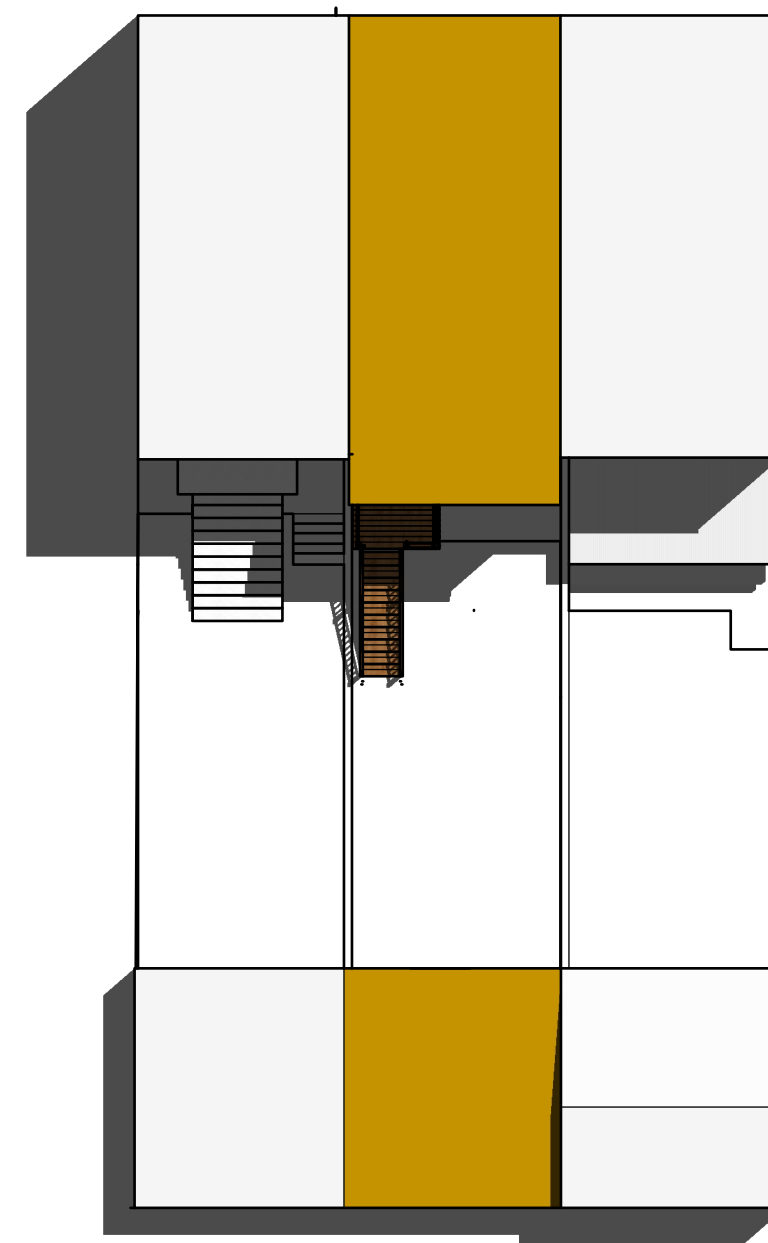

JUNE
SUMMER

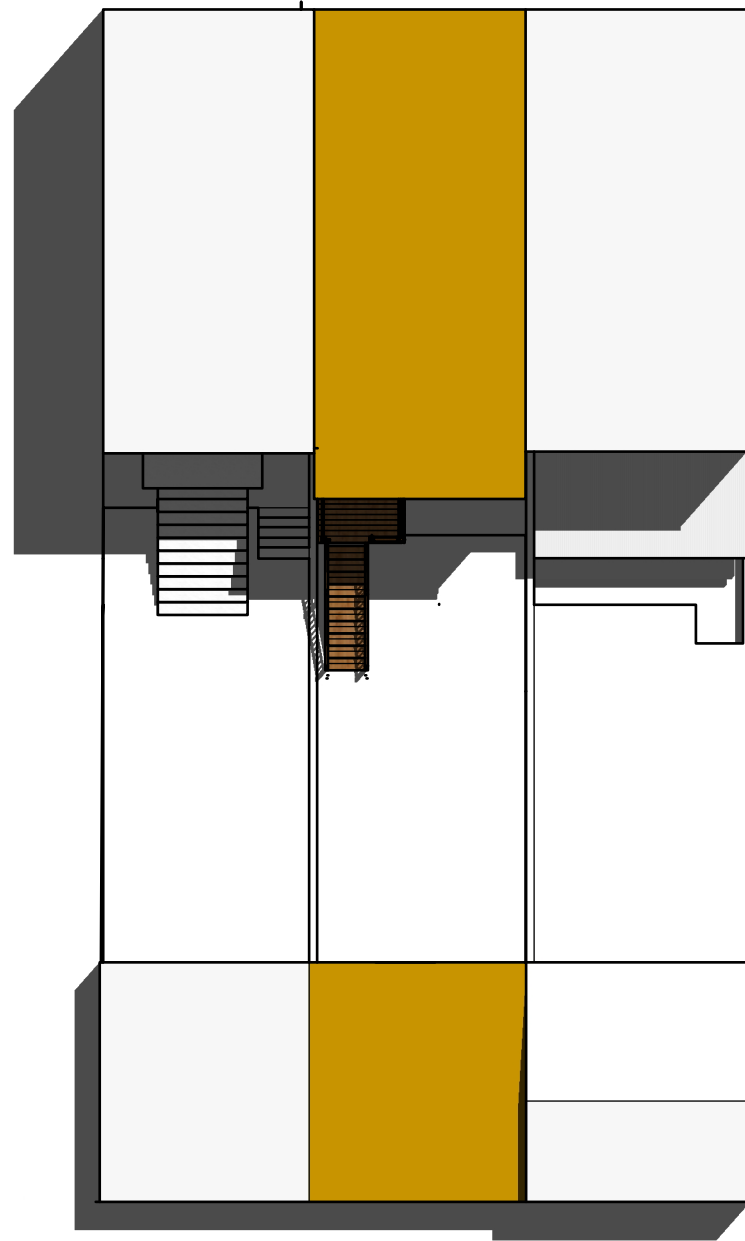

JULY
SUMMER

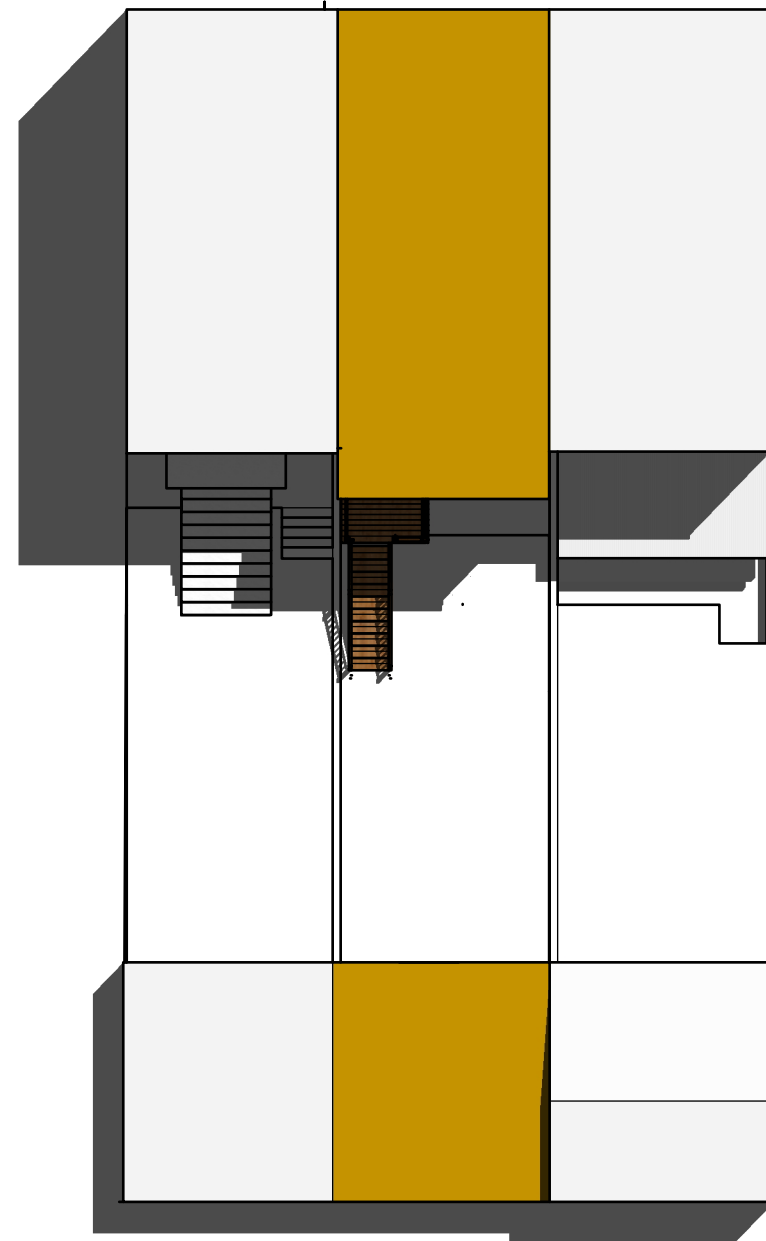

AUGUST
SUMMER

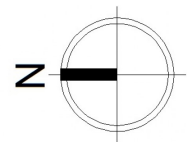
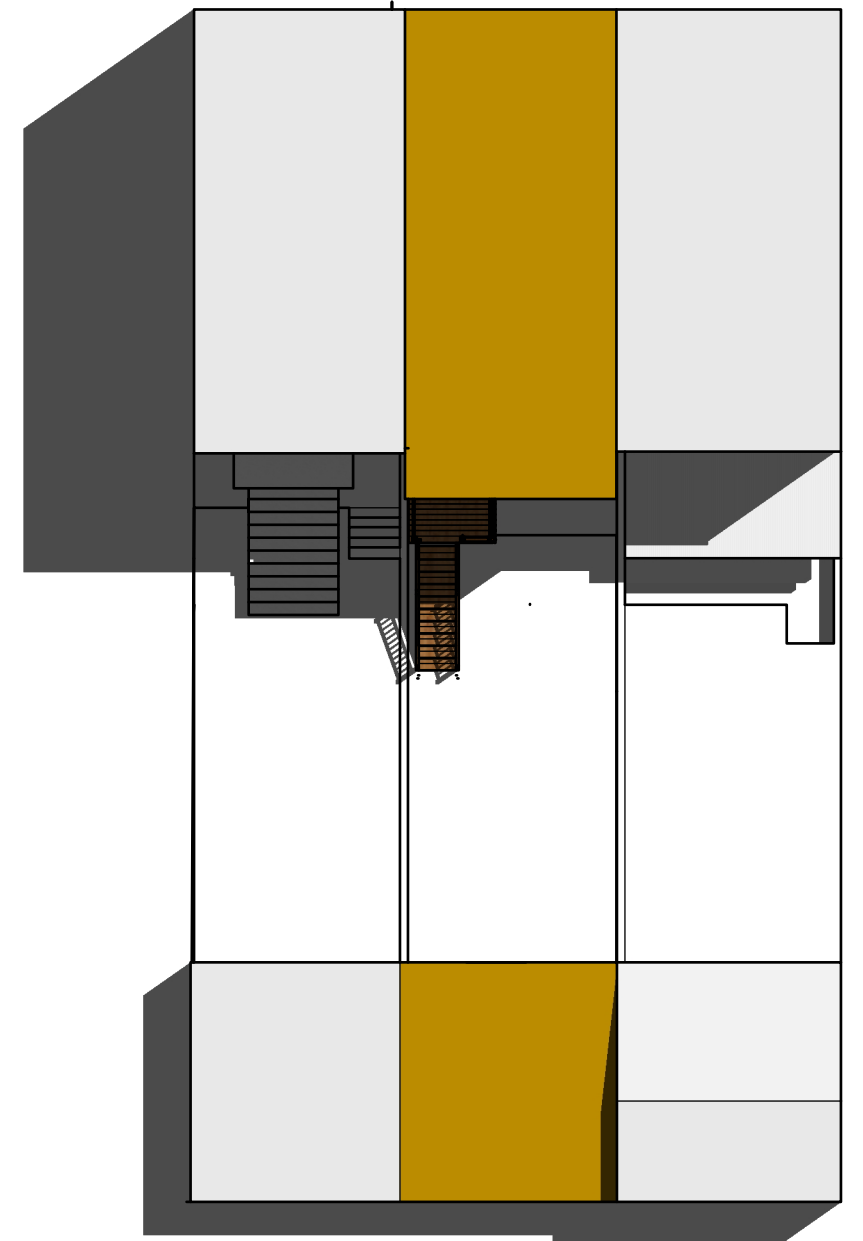

SEPTEMBER

FALL

OCTOBER

FALL

NOVEMBER

FALL

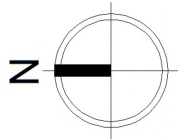
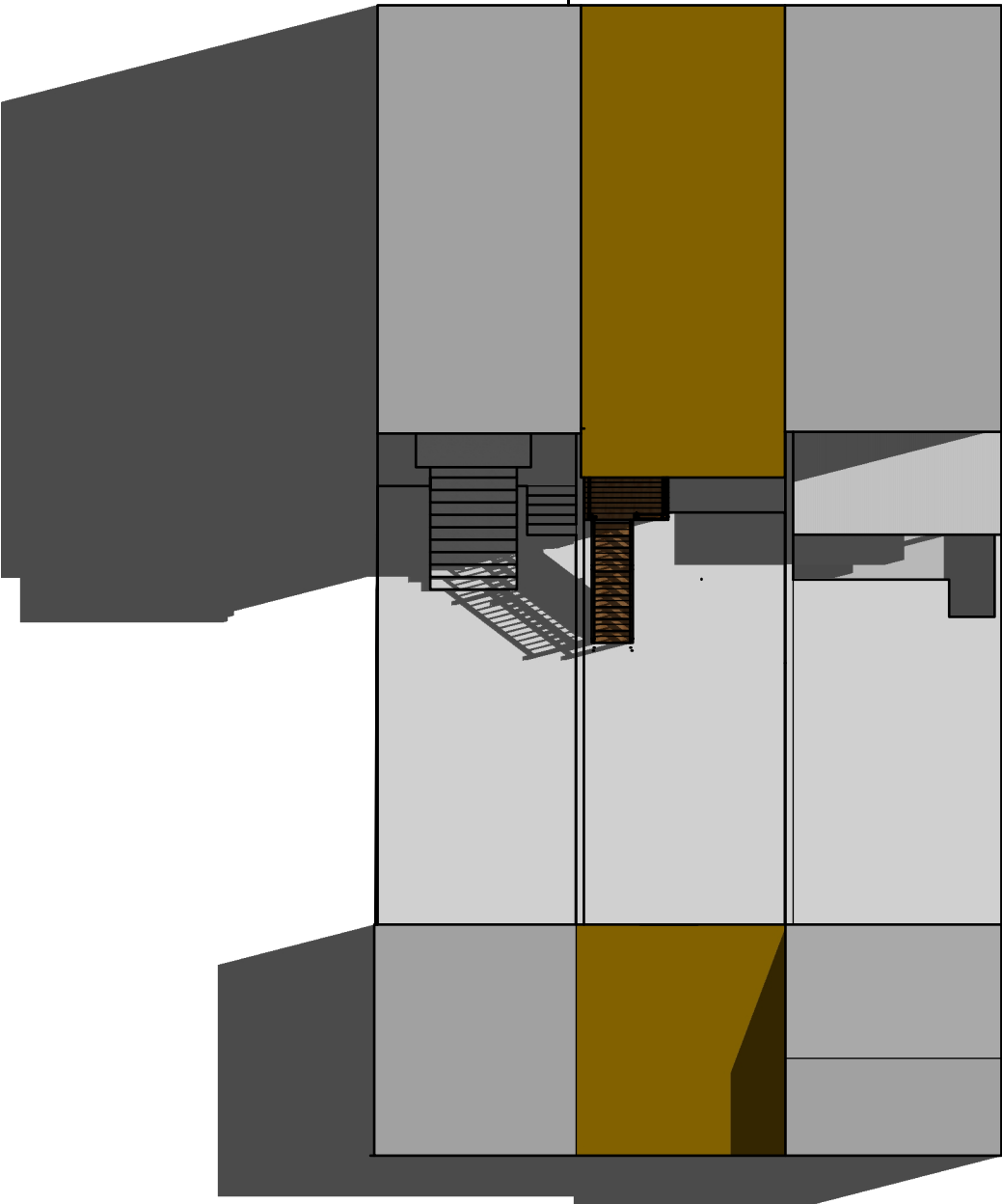
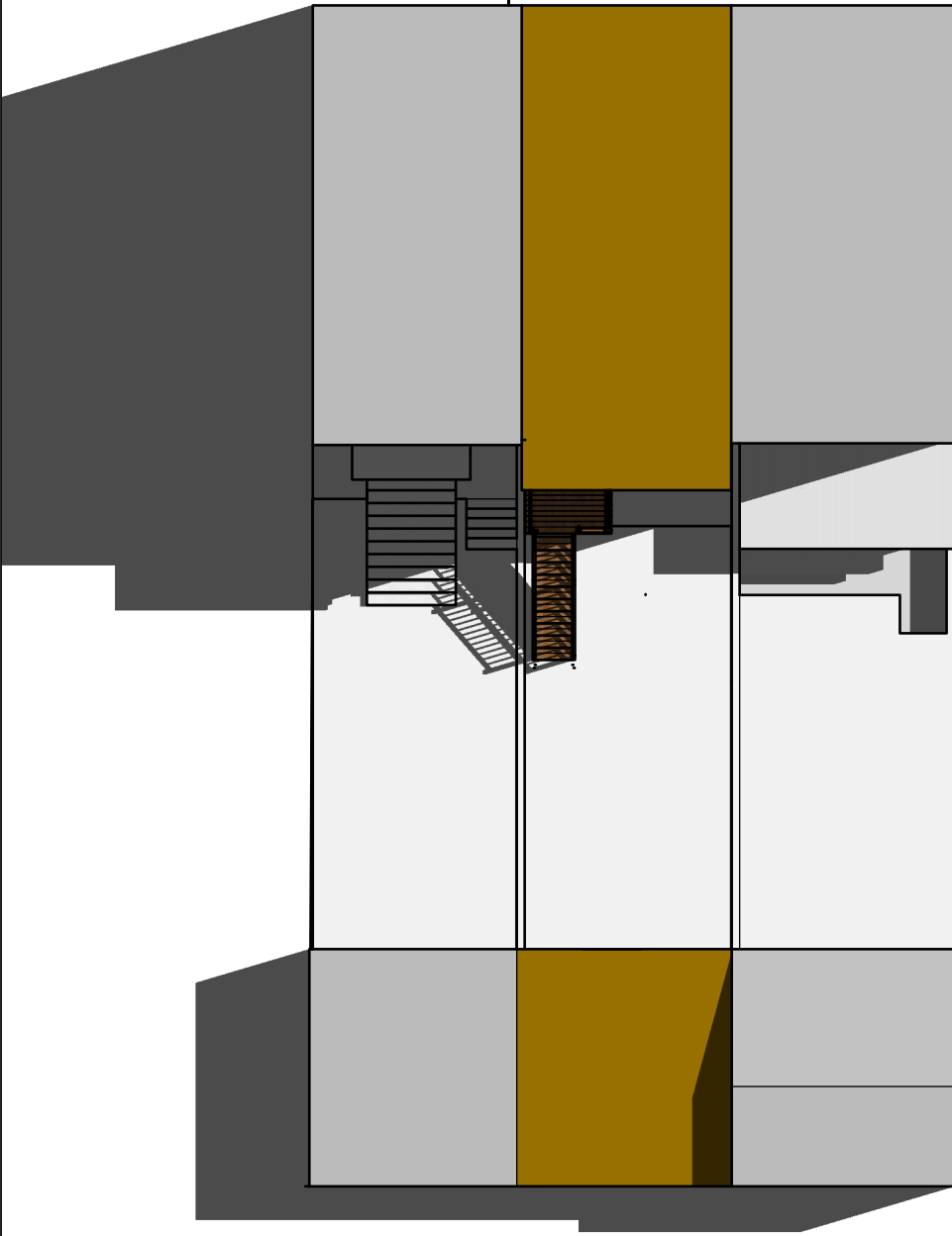
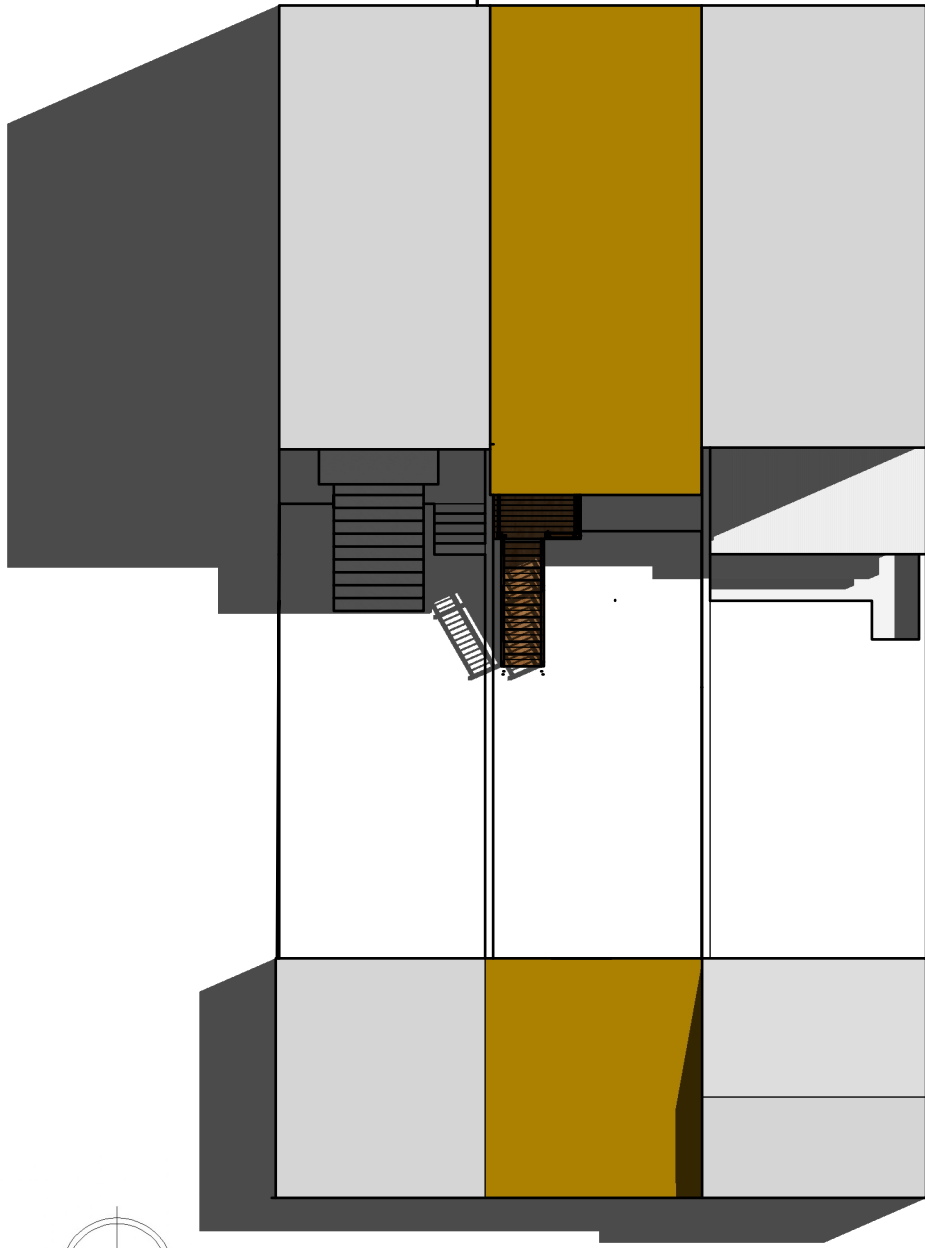

DECEMBER

WINTER

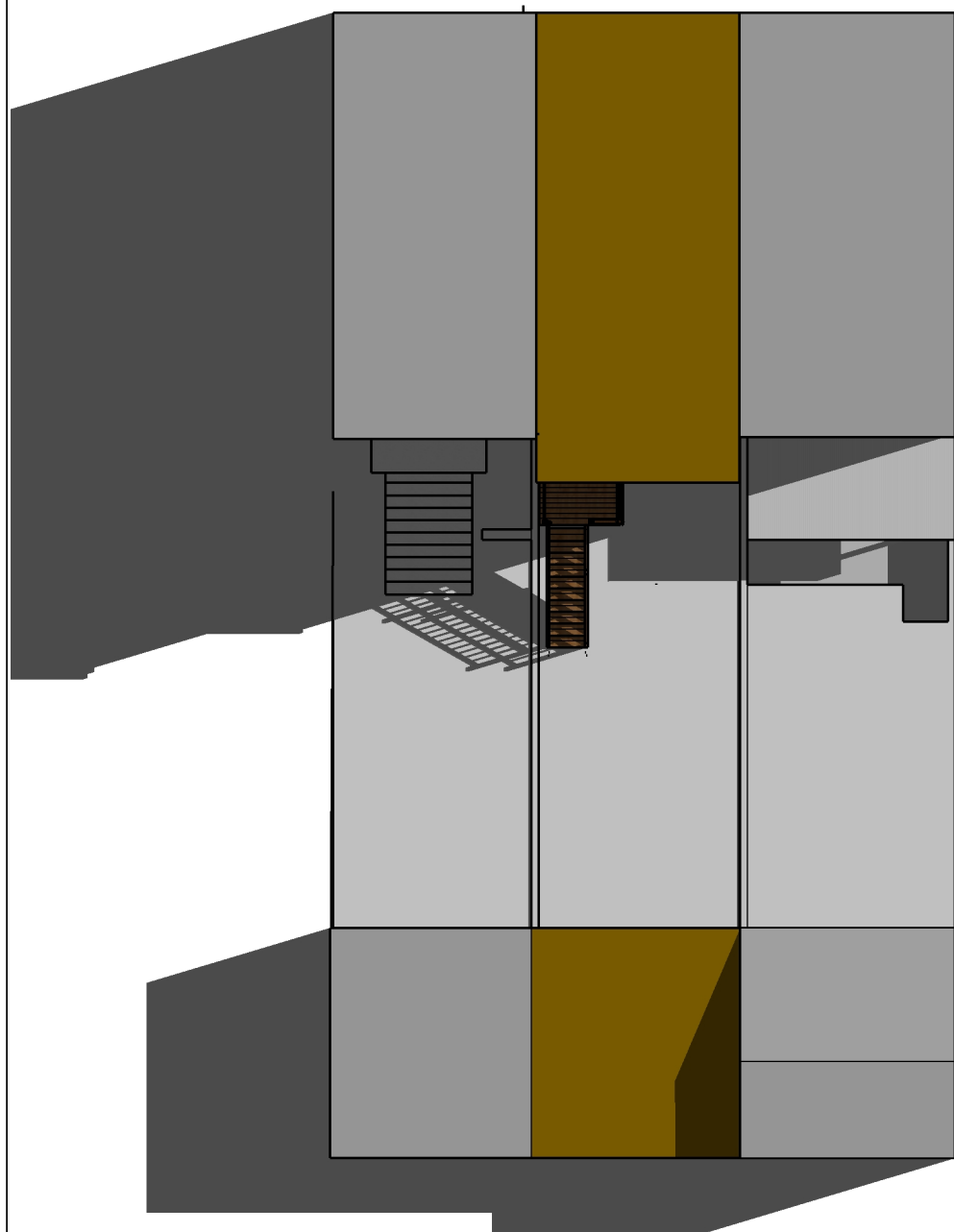

JANUARY

WINTER

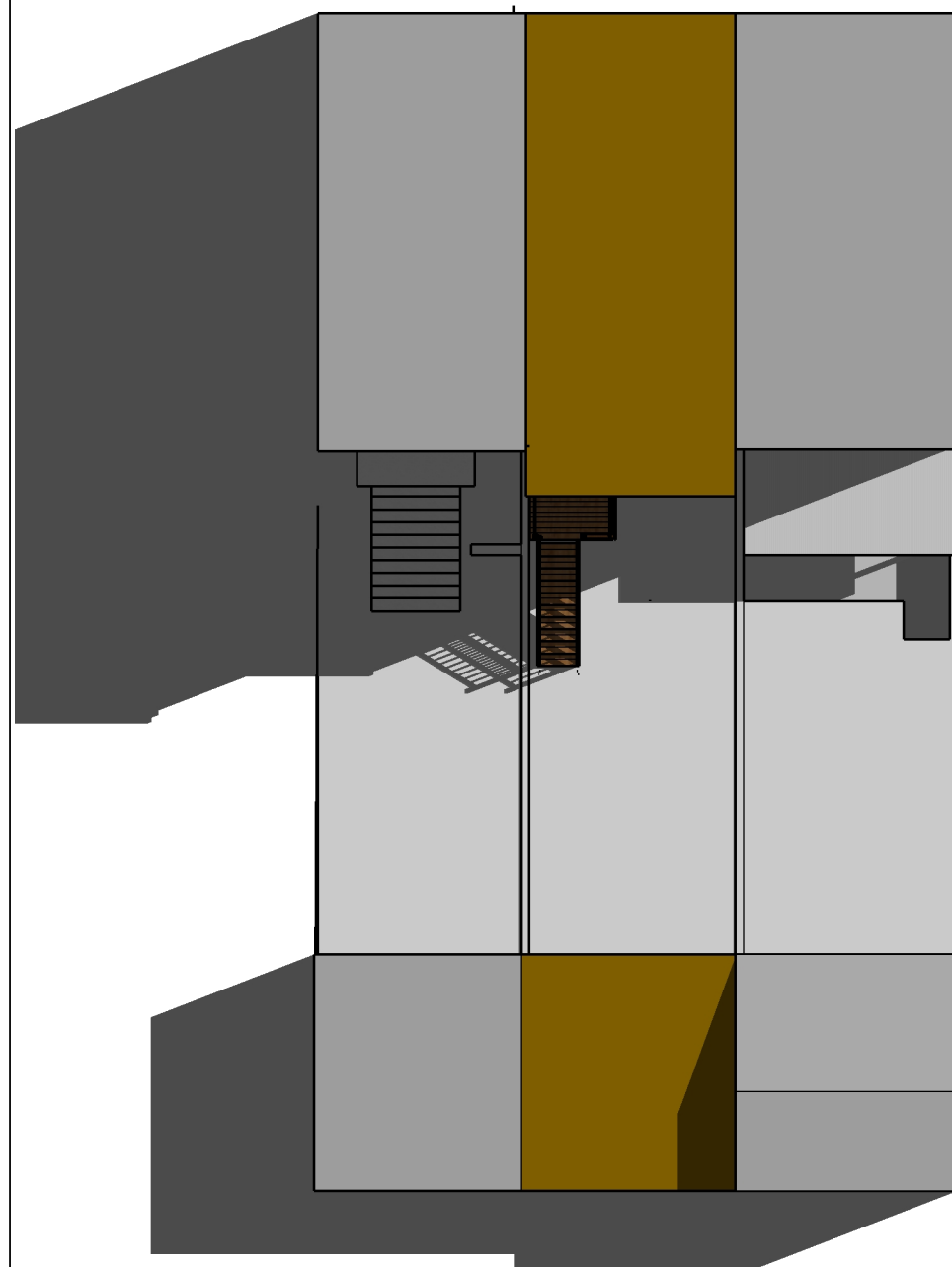

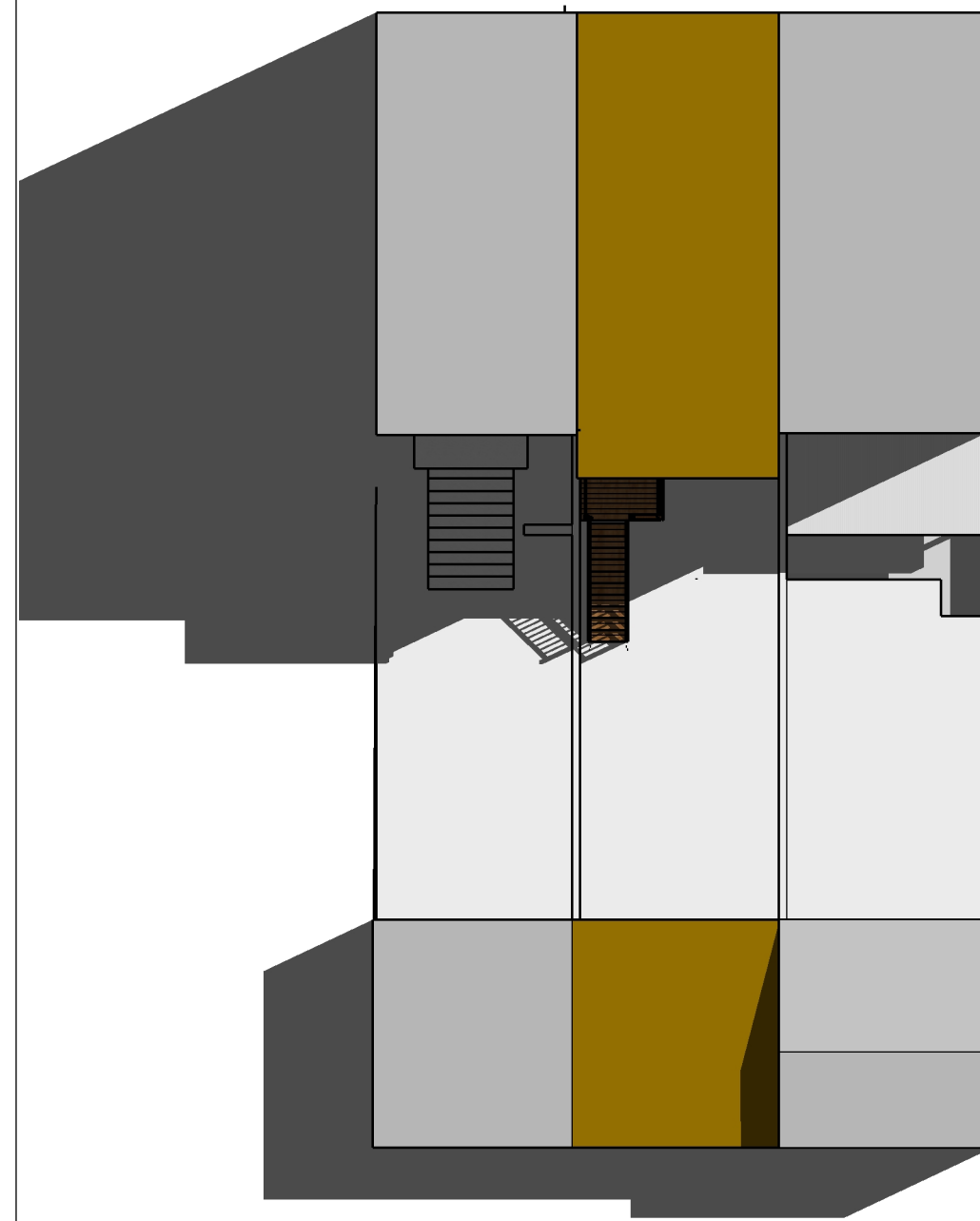

FEBRUARY

WINTER

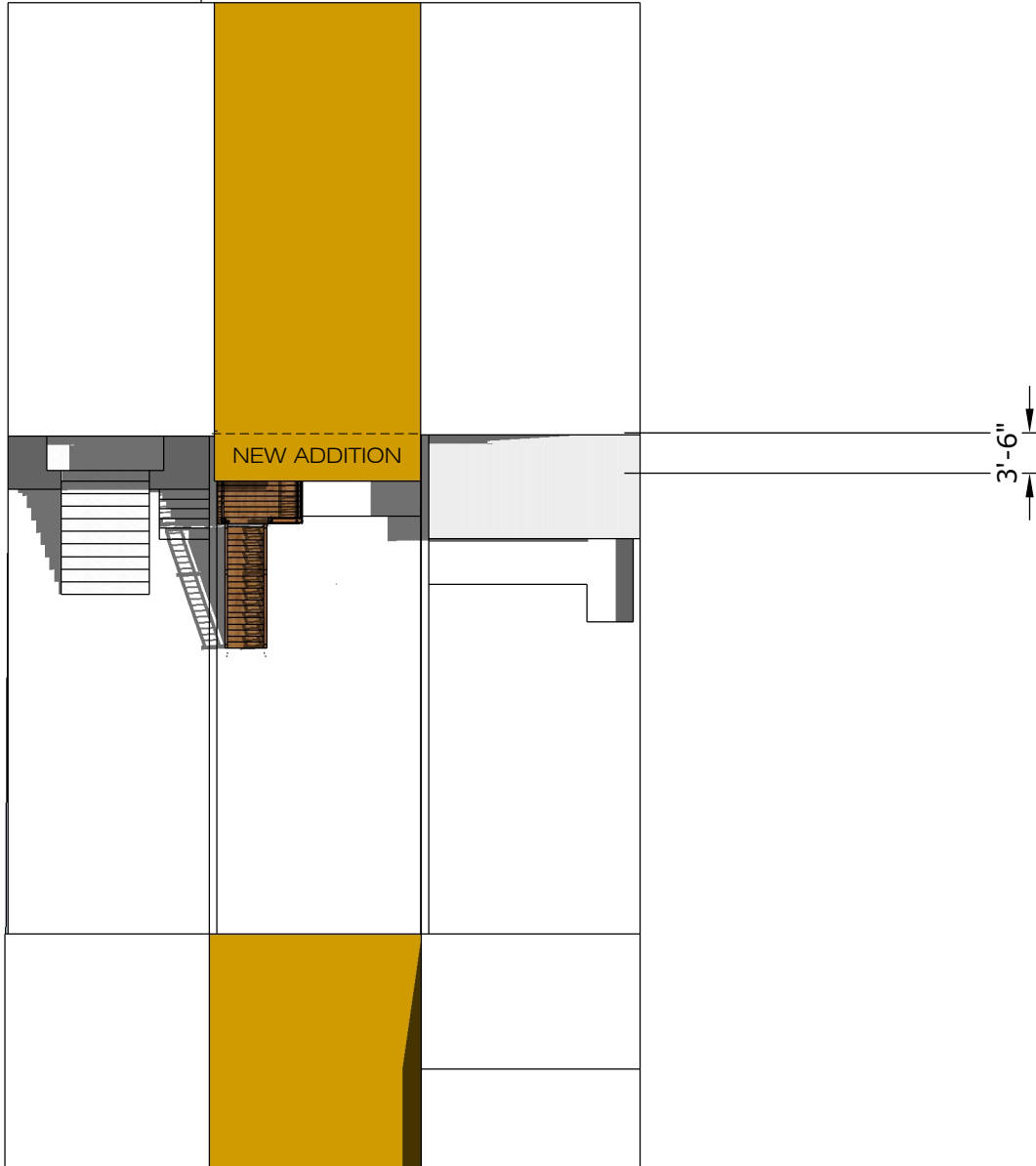
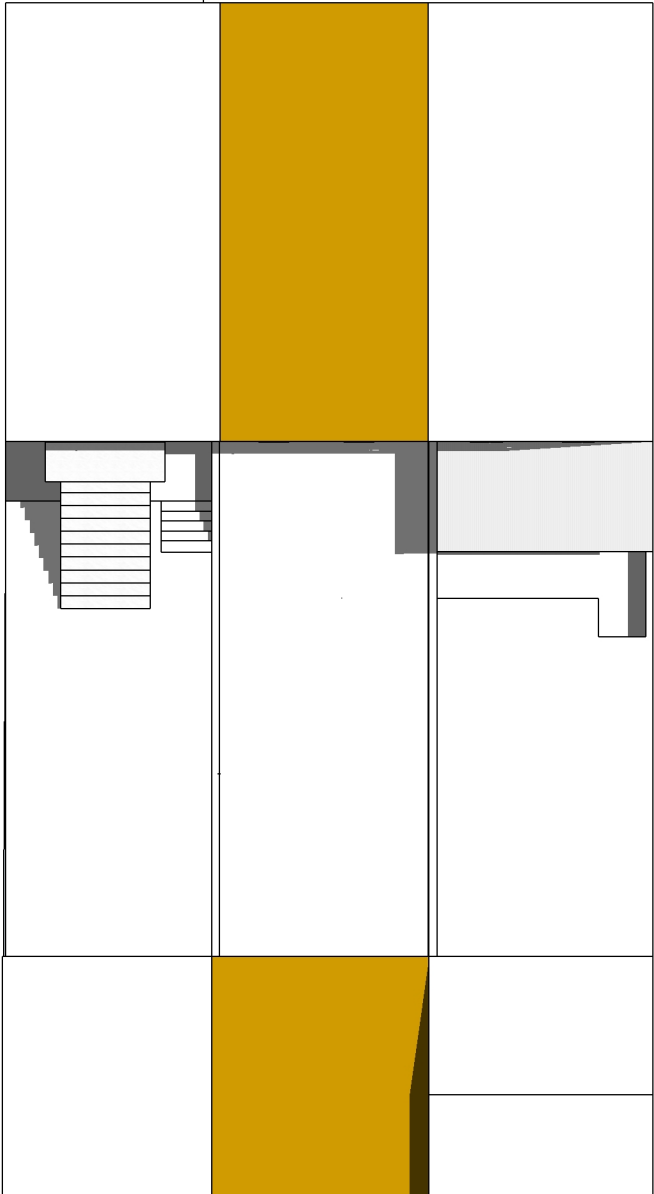
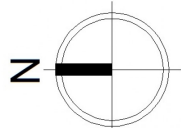

SPRING (MAY) - TOP VIEW 11:00AM



-  1832 15TH ST NW.
-  NEIGHBORING PROPERTIES

SUN STUDY

SUMMER (AUGUST) - TOP VIEW 10:00AM

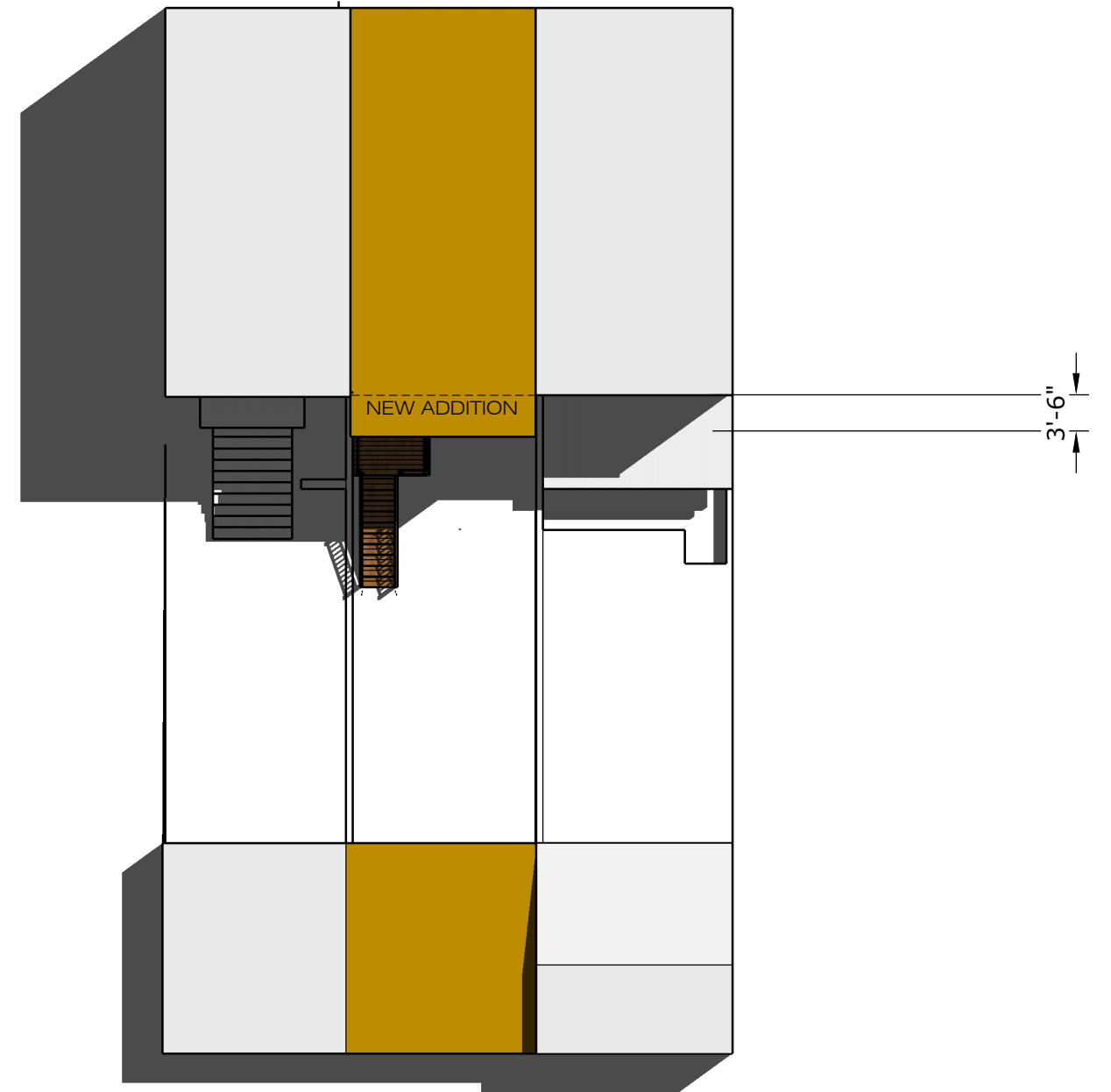
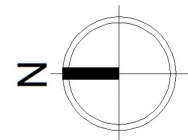
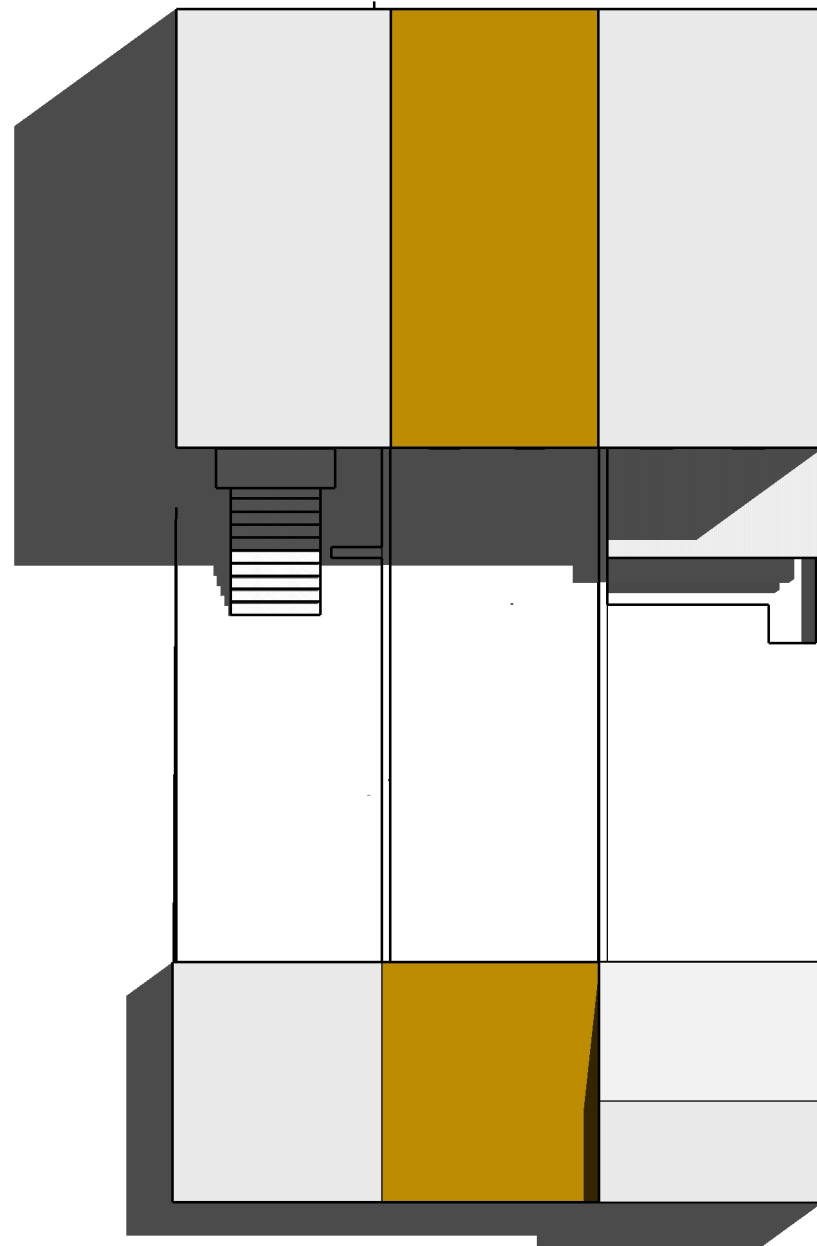

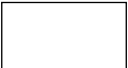
-  1832 15TH ST NW.
-  NEIGHBORING PROPERTIES

SUN STUDY

SPRING AND SUMMER PERSPECTIVES - 13:00pm

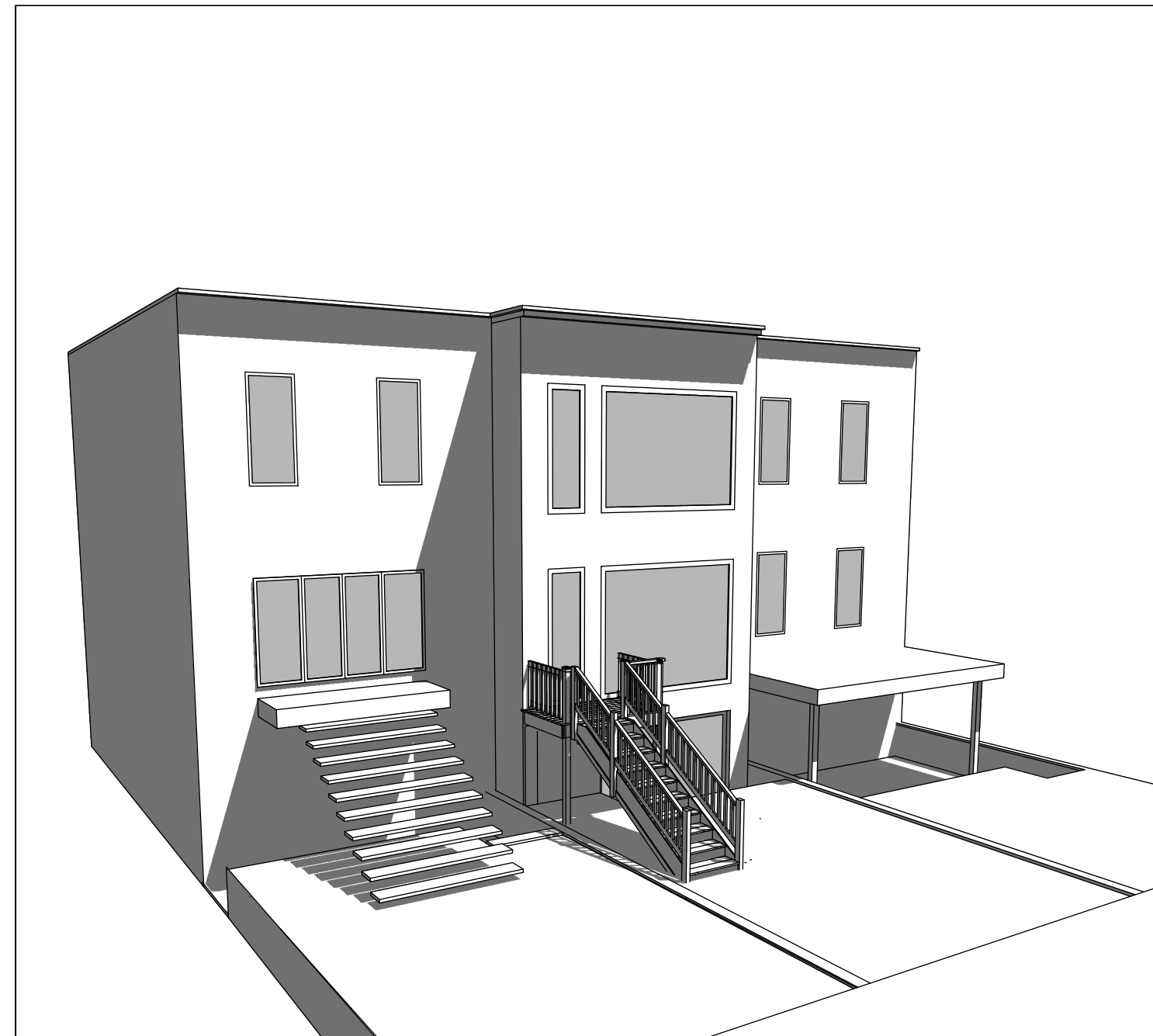

SUN STUDY

FALL (OCTOBER) - TOP VIEW 11:30AM

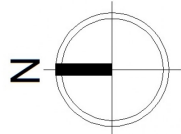
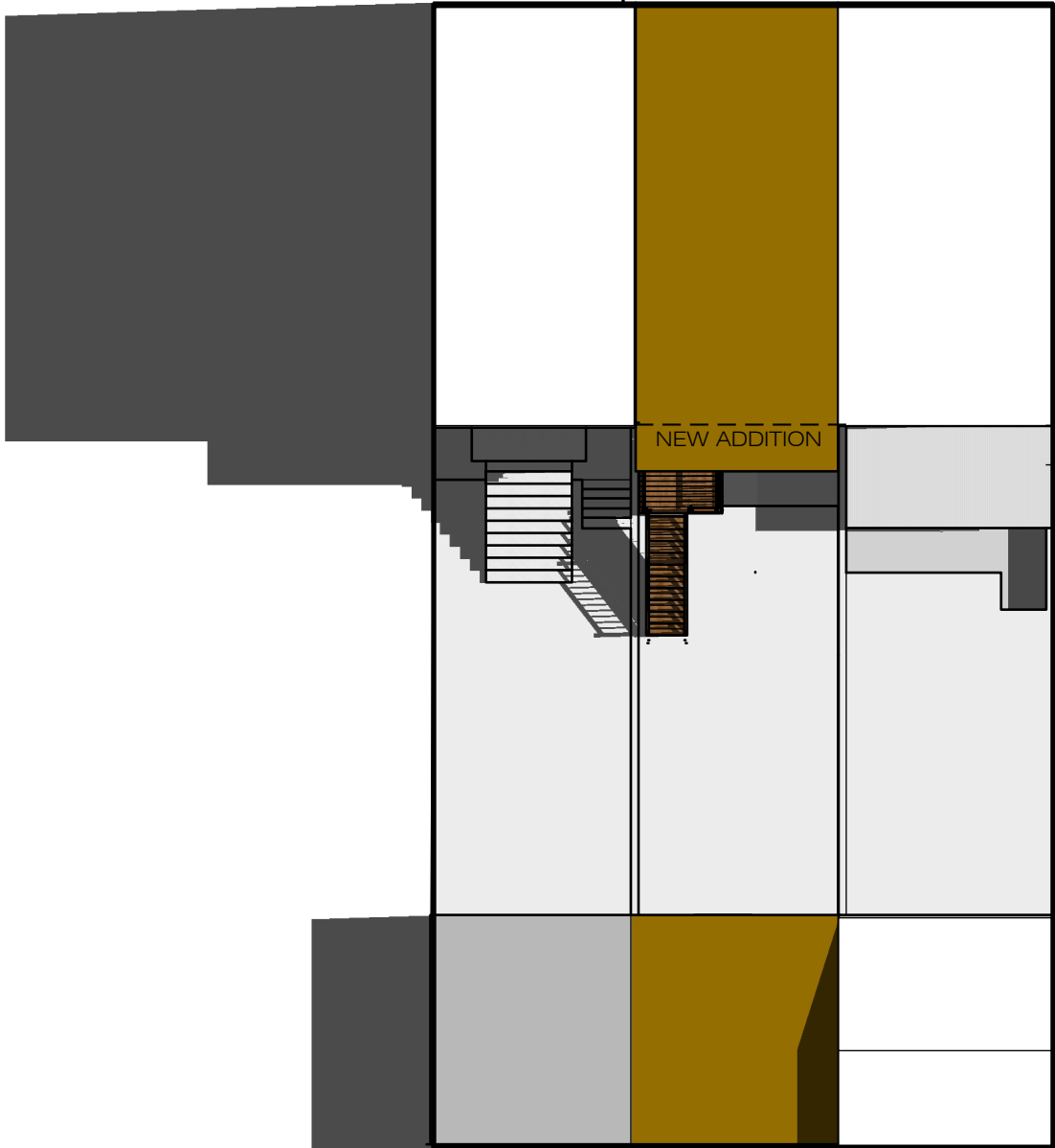
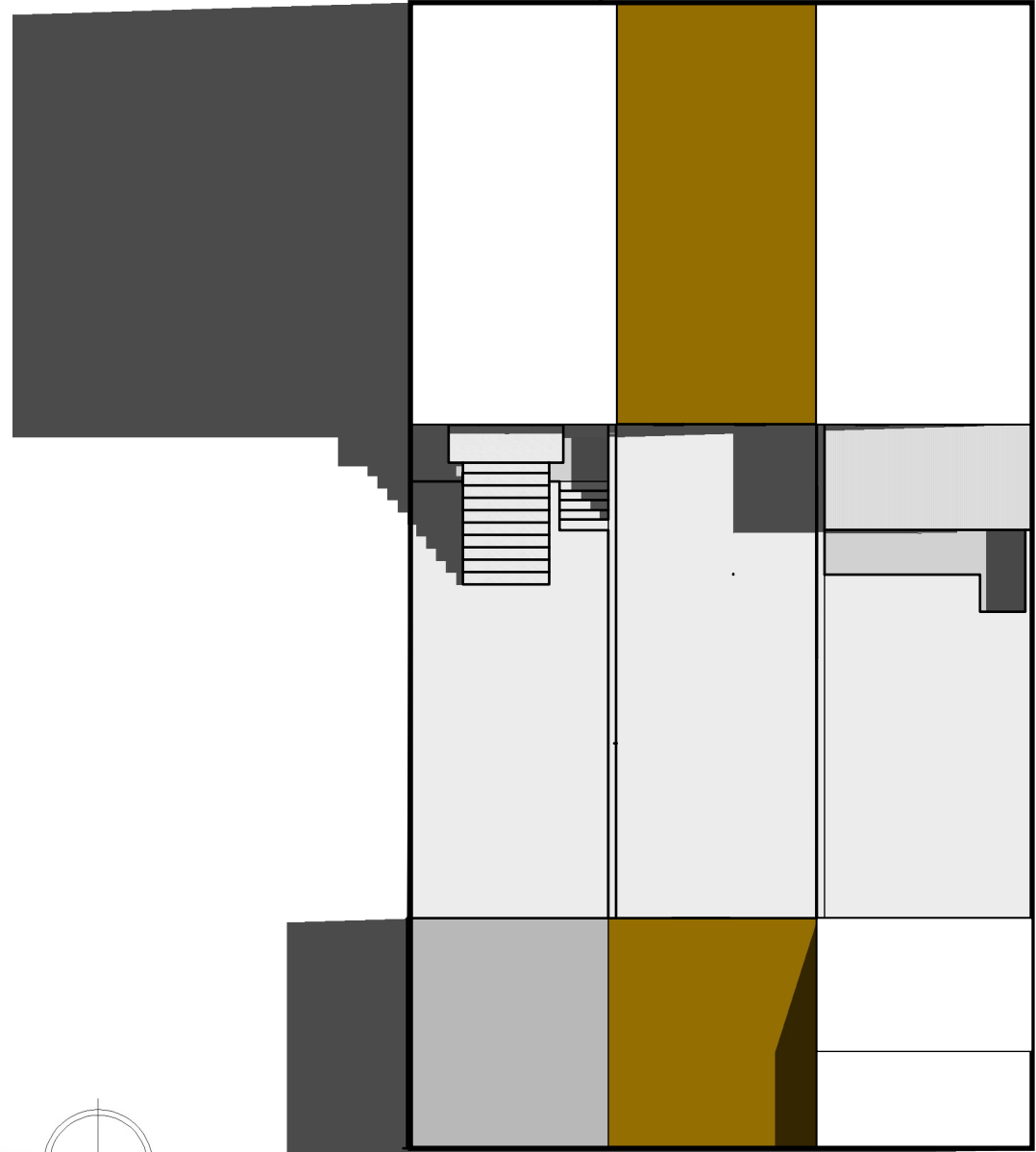

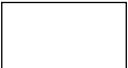

-  1832 15TH ST NW.
-  NEIGHBORING PROPERTIES

SUN STUDY

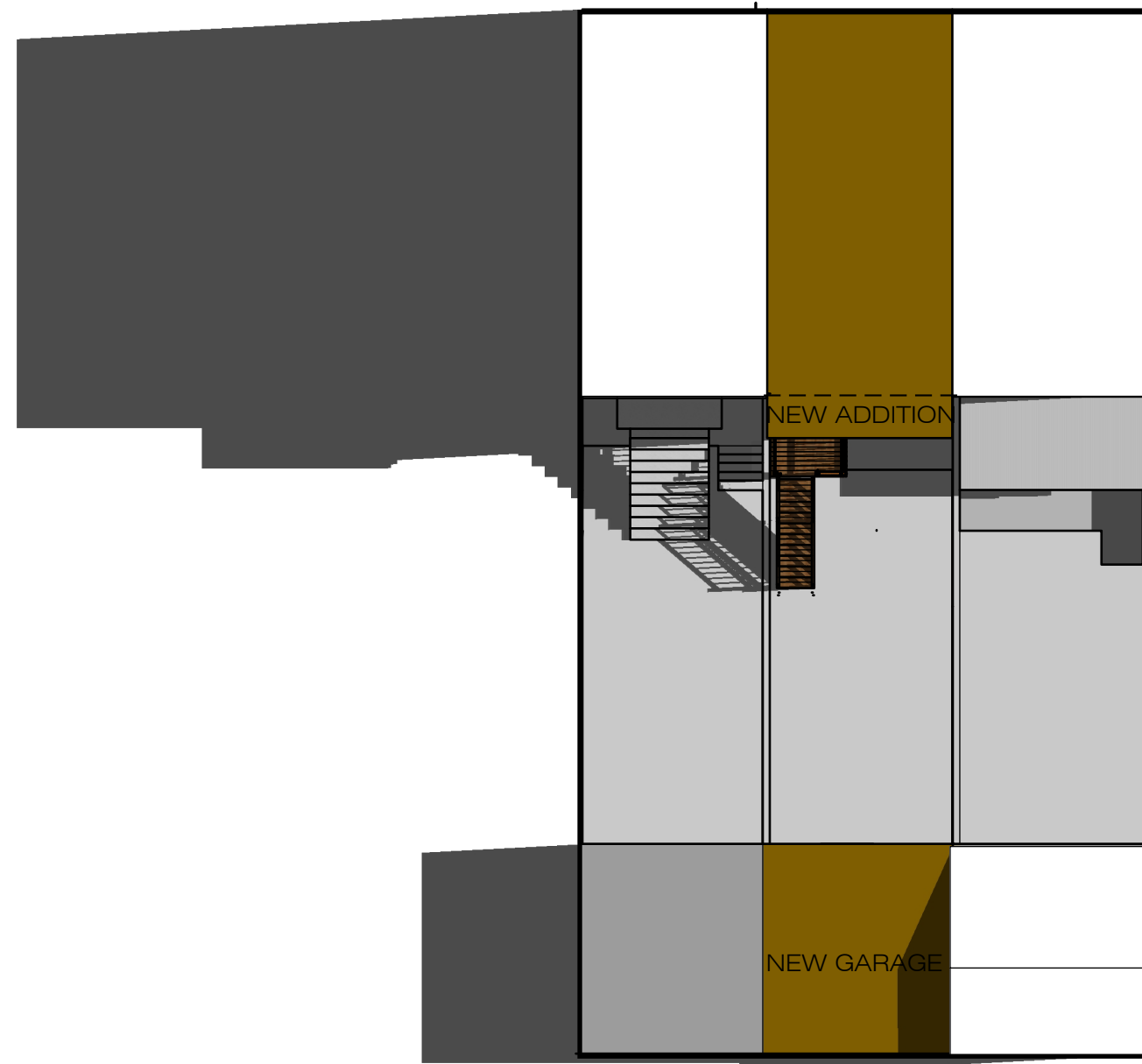
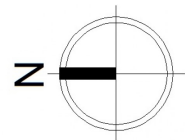
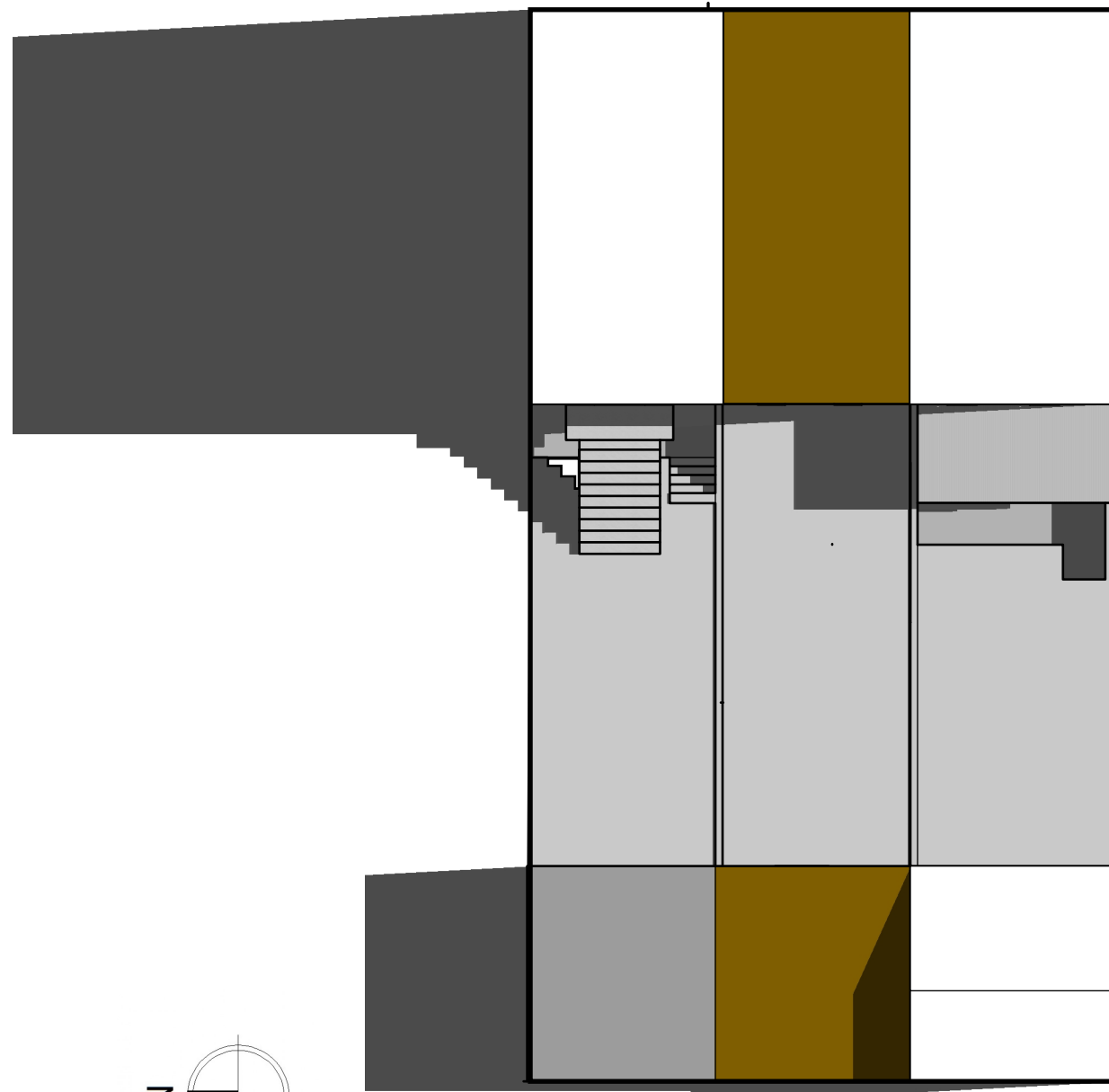
WINTER (JANUARY) - TOP VIEW 12:00PM



3'-6"

-  1832 15TH ST NW.
-  NEIGHBORING PROPERTIES

SUN STUDY

FALL AND WINTER PERSPECTIVES - 13:00 pm

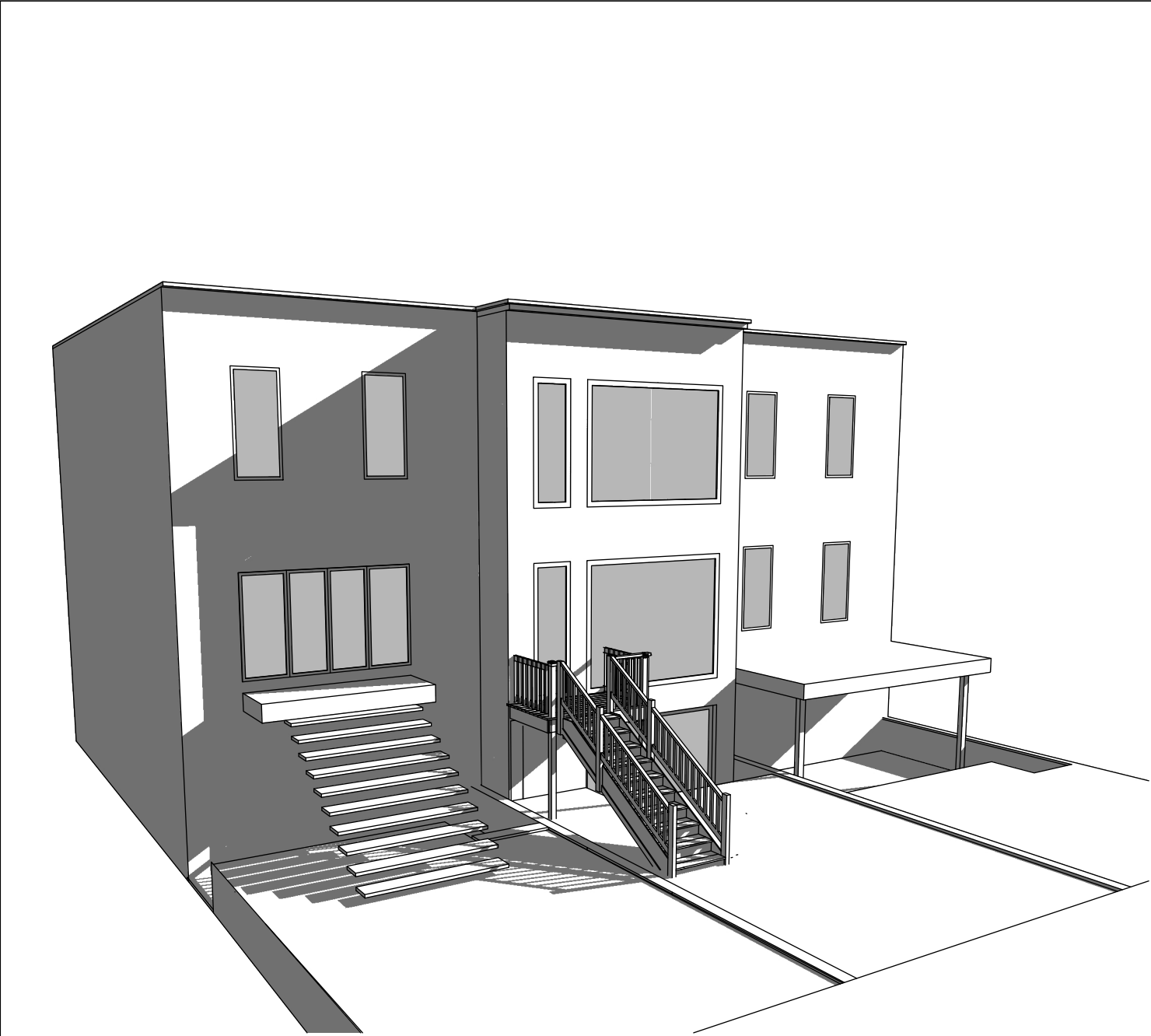
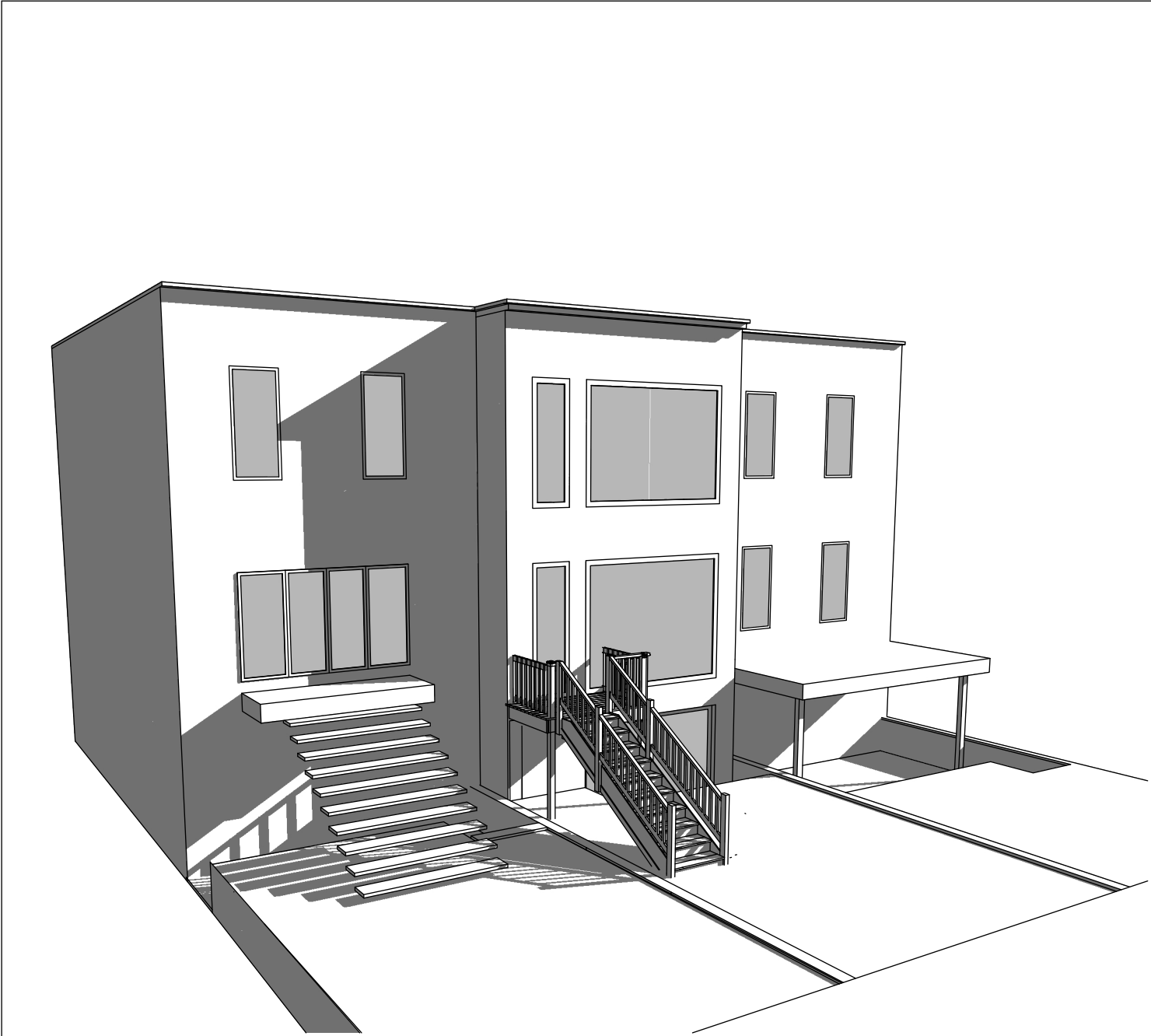

SUN STUDY